

INSTALLATION INSTRUCTIONS

**MID WIDTH REAR BUMPER
2018-ON JEEP WRANGLER JL ONLY**

**MID WIDTH REAR BUMPER
2018-ON JEEP WRANGLER JL ONLY**

PARTS LIST:

1	Rear Bumper	2	14mm Lock Washers
1	License Plate Bracket	2	14mm x 28mm x 2.5mm Flat Washers
2	LED License Plate Lights	2	8mm x 20mm Hex Bolts
4	Sensor Sealing Washers	4	8mm x 16mm x 1.6mm Flat Washers
4	Sensor Retaining Clips	2	8mm Nylon Lock Nuts
4	Sensor Foam Spacer	2	5mm x 15mm Hex Bolts
4	Sensor Hole Plugs	4	5mm x 15mm x 1.2mm Flat Washers
1	Sensor Cover Kit	2	5mm Nylon Lock Nuts
1	14-1.50mm Fine Thread Double Nut Plate	8	4mm x 10mm Button Head Bolts
2	14-1.50mm x 55mm Fine Thread Hex Bolts	1	4mm Wrench

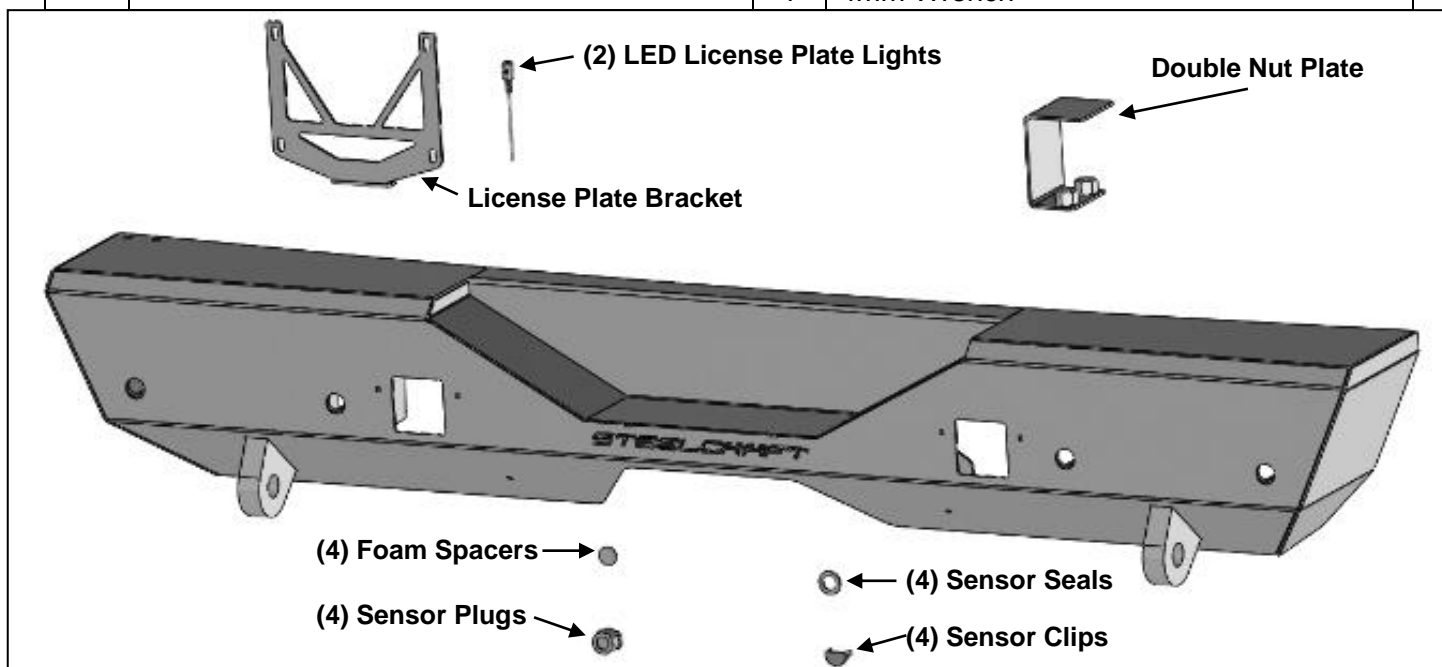

PROCEDURE: EDITING

REMOVE CONTENTS FROM BOX. VERIFY ALL PARTS ARE PRESENT. READ INSTRUCTIONS CAREFULLY BEFORE STARTING INSTALLATION.

WARNING: ALLOW TIME FOR THE MUFFLER TO COMPLETELY COOL BEFORE REMOVING REAR BUMPER.

1. Start installation from under the Driver/Left side of the rear bumper. Remove the plastic cover from the back of the rear wheel opening, **(Figure 1)**. Locate and remove the (2) hex bolts attaching the outer bracket running from the side of the frame to the outer end of the bumper, **(Figure 2)**. Remove the (2) hex bolts attaching the bottom of the bumper to the rear crossmember if equipped, **(Figure 3)**. Repeat this **Step** on the Passenger/Right side of the vehicle.
2. Unplug the wiring harness leading to the rear bumper.
3. With assistance, remove the (4) hex nuts attaching the bumper to the inner bumper brackets, **(Figure 4)**. Slide bumper off of the inner and outer bumper brackets.
4. Remove the Driver/Left outer bumper bracket attached to the side of the frame, **(Figure 4)**. Next, remove the (4) hex bolts attaching the tow hook to the Driver/Left side of the frame and remove the inner bumper bracket, **(Figure 5)**.
5. Repeat **Step 4** to remove the Passenger/Right side bumper brackets.
6. Insert the Double Nut Plate into the open end of the frame. Line up the Nut Plate with the holes in the bottom of the frame, **(Figure 6)**.

**MID WIDTH REAR BUMPER
2018-ON JEEP WRANGLER JL ONLY**

7. Determine if the vehicle is equipped with bumper mounted sensors. **NOTE:** Depending on tow package, it may be necessary or easier to install sensors, (if equipped), and harness before installing the Bumper.

Models without bumper sensors:

- a. Select the included (4) Rubber Plugs, **(Figure 7)**.
- b. From behind bumper, push plugs into sensor mounting sleeves, **(Figure 7)**. Screws have been provided to lock the plugs into the sleeves. Use is optional.

Models with bumper mounted sensors:

- a. Disassemble the factory bumper to remove the wiring harness and sensors.
 - b. Select (1) sensor. Remove the seal from the end of the sensor. Slide the included flat Sensor Seal Washer over front of the sensor, **(Figure 8)**.
 - c. Insert the sensor with Seal into sensor mount, **(Figure 9)**.
 - d. Place Foam Spacer over end of the sensor. Push Sensor Retaining Clip into sensor mount and lock into mounting holes, **(Figure 9)**.
 - e. Repeat previous Steps to install remaining sensors.
 - f. Install wiring harness for sensors and plug harness into sensors.
 - g. **Optional:** Secure each sensor to the socket with (2) 4mm x 10mm Button Head Screws, **(Figure 7)**. **IMPORTANT:** Sensors fit snug in sockets. The 4mm Screws are used to apply slight pressure to lock the sensors in place. Tighten both screws evenly until they touch the sensor body only. Do not overtighten screws or damage to sensors will result.
8. With assistance, carefully position the Rear Bumper up to the outside of the frame. Attach the Bumper to the Nut Plate in the Passenger/Right frame end with the included (2) 14mm Fine Thread Hex Bolts, (2) 14mm Lock Washers and (2) 14mm Flat Washers, **(Figure 10)**. Reuse the factory hex bolts to attach the Bumper to the threaded inserts in the bottom and sides of the frame on both ends of the Bumper, **(Figures 10—13)**. Do not tighten hardware at this time.
9. Level and adjust the Rear Bumper and tighten all hardware at this time.
10. Select the License Plate Bracket, **(Figure 14)**. Attach the Bracket to the top of the Bumper with the included (2) 8mm x 20mm Hex Bolts, (4) 8mm Flat Washers and (2) 8mm Nylon Lock Nuts. Attach the license plate to the top holes in the Bracket with the included (2) 5mm x 15mm Hex Bolts, (4) 5mm Flat Washers and (2) 5mm Nylon Lock Nuts, **(Figure 15)**.
11. Select the (2) LED License Plate Lights. Attach the Lights to the bottom (2) holes in the license plate and Bracket, **(Figure 15)**. Attach the wiring on the License Plate Lights to the wire harness for the factory license plate light.
12. On models with sensors, plug-in the bumper wiring harness to the main harness.
13. Do periodic inspections to the installation to make sure that all hardware is secure and tight.

To protect your investment, Do not use any type of polish or wax that may contain abrasives that could damage the finish. Mild soap may be used to clean Bumper.

MID WIDTH REAR BUMPER
2018-ON JEEP WRANGLER JL ONLY

Driver/Left Side Installation Pictured

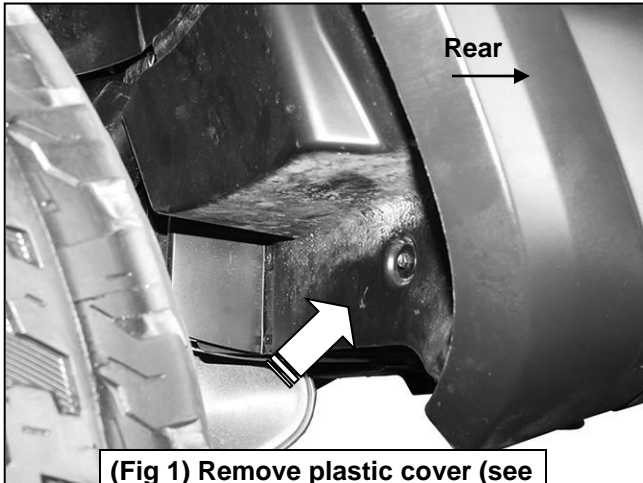

(Fig 1) Remove plastic cover (see arrow-Driver/Left side pictured)

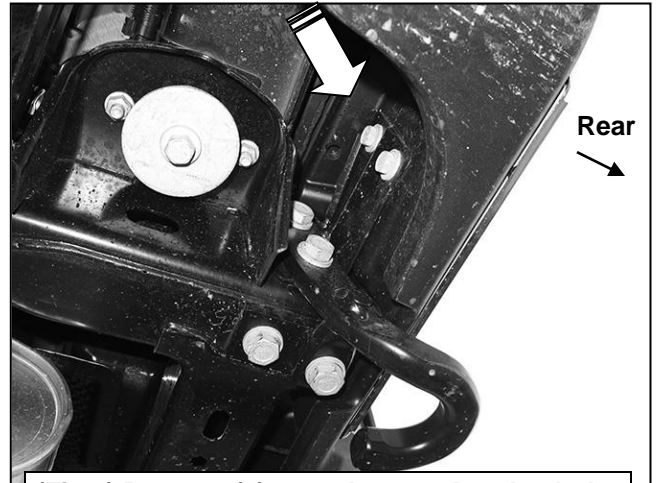

(Fig 2) Remove (2) outer bumper bracket bolts



(Fig 3) Remove (2) hex bolts attaching bottom of bumper to frame cross member

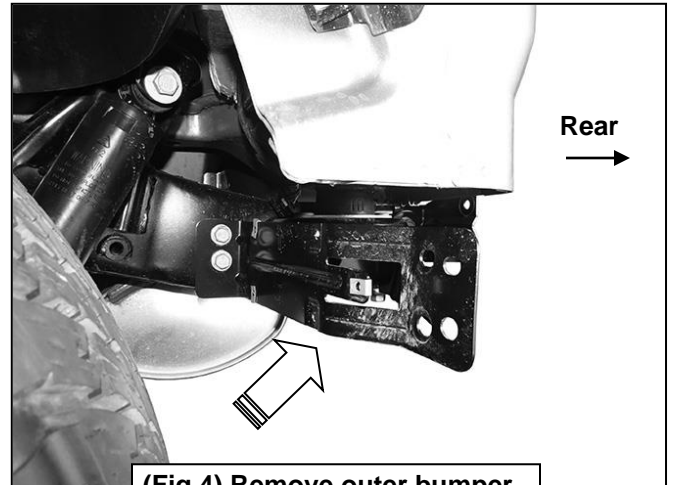

(Fig 4) Remove outer bumper bracket from side of frame

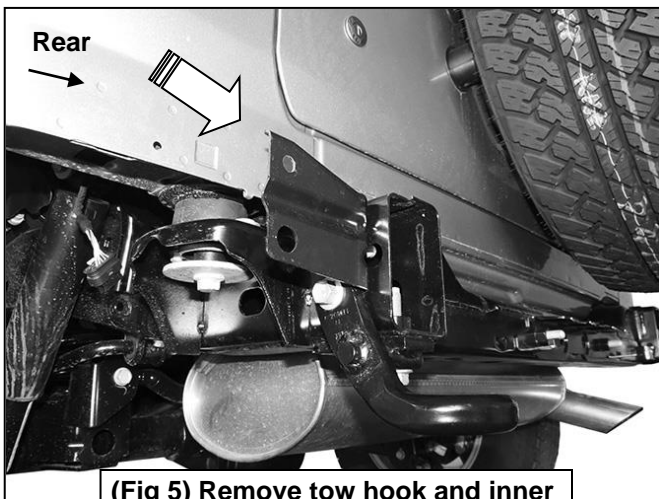

(Fig 5) Remove tow hook and inner bumper bracket from side of frame

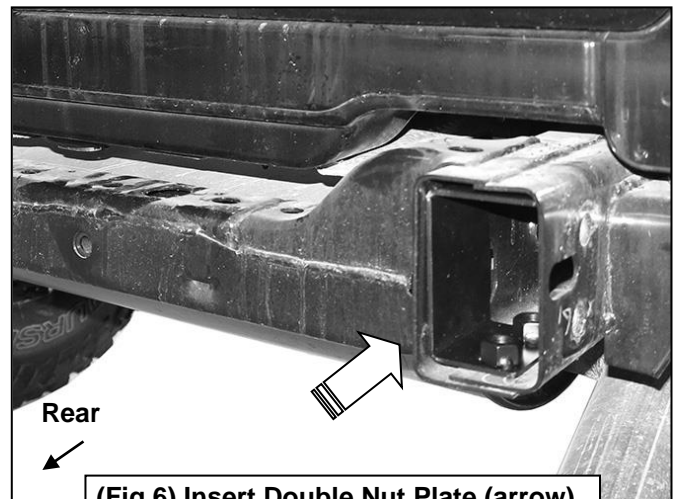

(Fig 6) Insert Double Nut Plate (arrow) into Passenger/Right end of frame

**MID WIDTH REAR BUMPER
2018-ON JEEP WRANGLER JL ONLY**

Driver/Left Side Installation Pictured

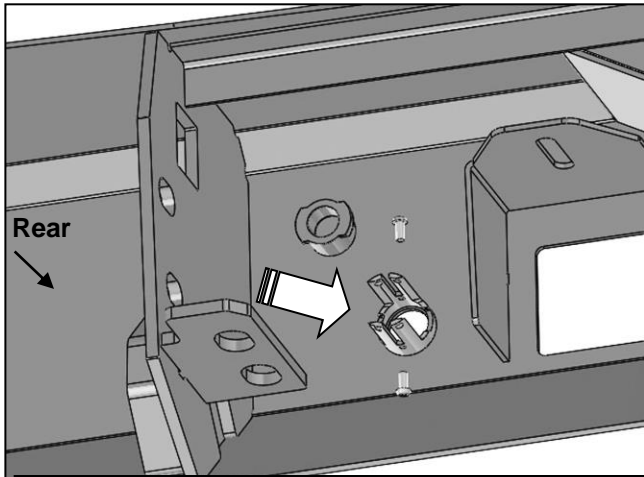

(Fig 7) Push Rubber Plug into mounting sleeve

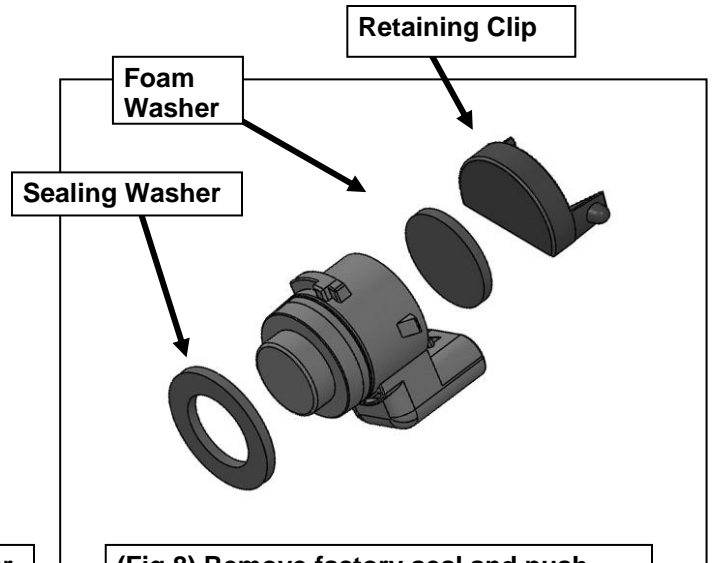

(Fig 8) Remove factory seal and push Flat Sealing Washer onto end of sensor

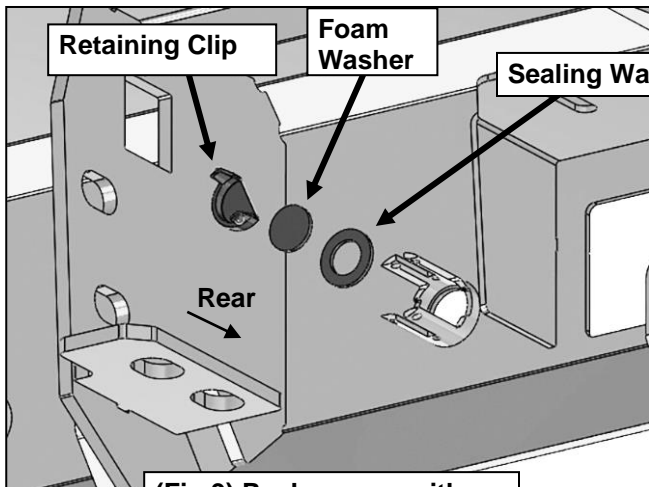

(Fig 9) Push sensor with Sealing Washer into sleeve

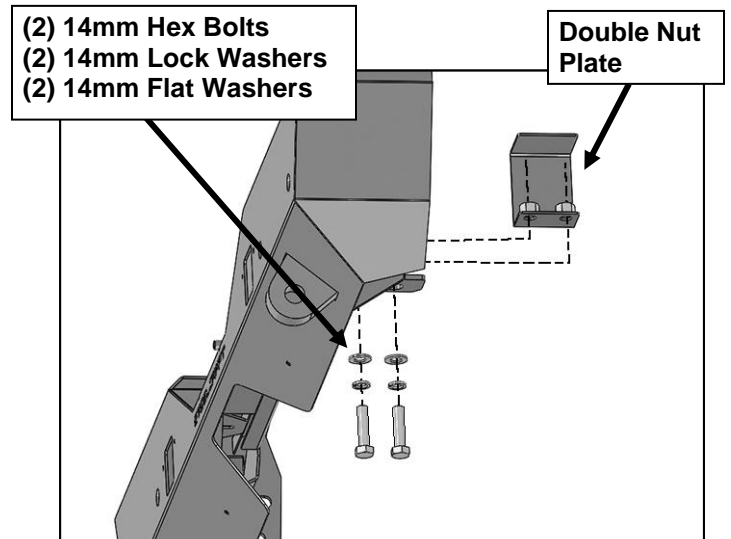

(Fig 10) Attach Passenger/Right side of Bumper to Double Nut Plate. Reuse (2) factory hex bolts to attach Bumper to side of frame (see Fig 11)

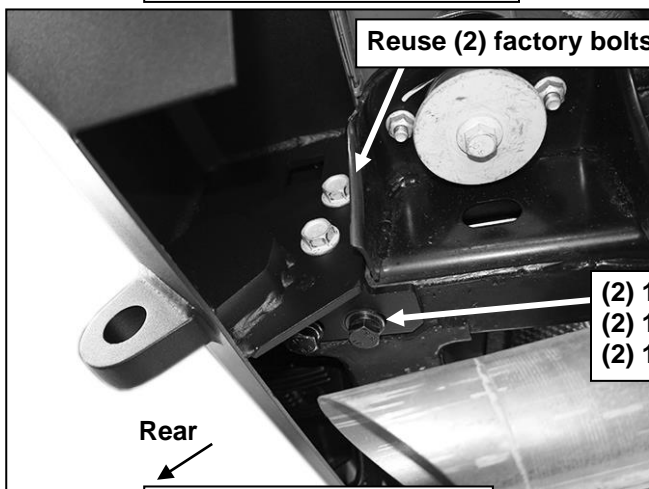

(Fig 11) Passenger/Right side of Bumper installed

Driver Side Installation Pictured

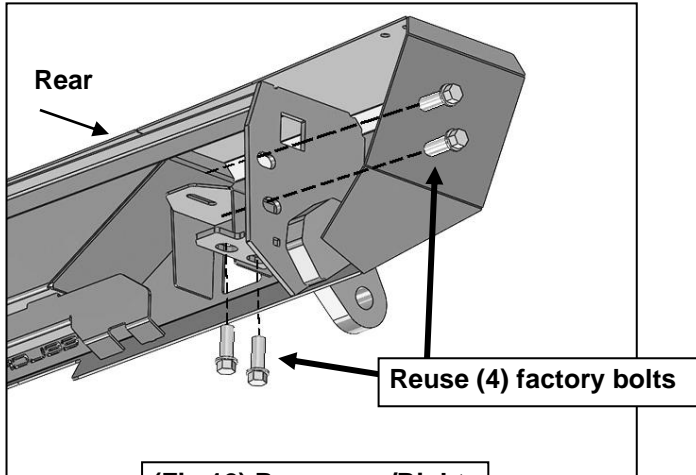

(Fig 12) Passenger/Right side of Bumper installed

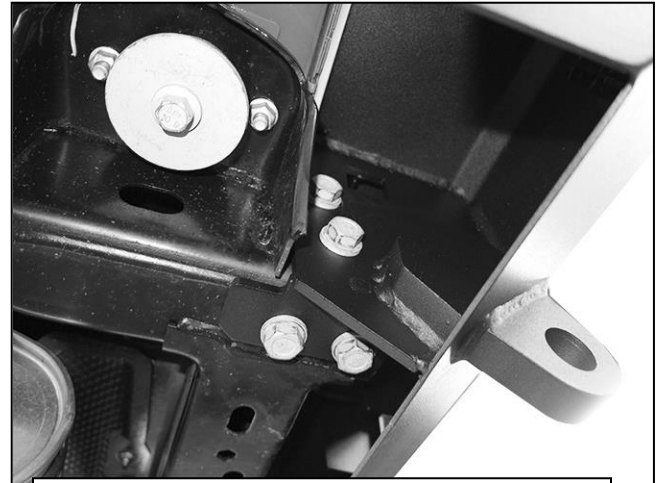

(Fig 13) Driver/Left side of Bumper installed

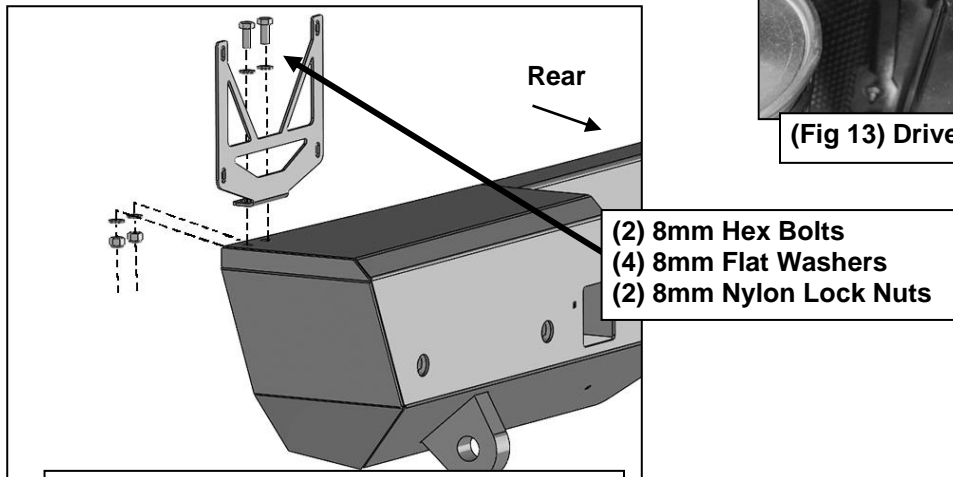

(Fig 14) Attach License Plate Bracket to the top of the Driver/Left side of the Bumper

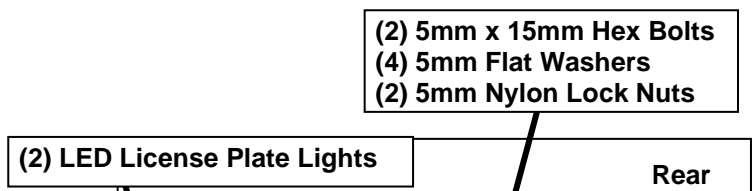

(Fig 15) Attach license plate lights and license plate to Bracket



Installation Complete