

A large, light gray watermark of the Ford logo is oriented diagonally across the page, from the top-left to the bottom-right. It is positioned behind the central text box.

# **INSTALLATION INSTRUCTIONS**

**ELEVATION BULL NOSE FRONT BUMPER  
2018 FORD F150**

**ELEVATION BULL NOSE FRONT BUMPER  
2018 FORD F150**

**PARTS LIST:**

1	Front Bumper Assembly	2	12-1.75mm x 170mm Hex Bolts
1	Winch Tray	26	12-1.75mm x 50mm Hex Bolts
1	Driver/Left Frame Mounting Bracket	52	12mm x 32mm x 3mm Flat Washers
1	Passenger/Right Frame Mounting Bracket	4	12mm Lock Washers
1	Driver/Left Support Bracket	24	12-1.75mm Nylon Lock Nuts
1	Passenger/Right Support Bracket	2	8-1.25mm x 25mm Hex Bolts
1	Driver/Left Fog Light Upper U-Bracket	2	8-1.25mm x 20mm Hex Bolts
1	Passenger/Right Fog Light Upper U-Bracket	2	8-1.25mm x 16mm Hex Bolts
2	Lower U-Brackets (Fog Lights)	10	8mm x 24mm x 2mm Flat Washer
1	Winch Cover Plate	2	8mm Lock Washers
1	Driver/Left LED "L" Light Bracket	4	8mm Nylon Lock Nuts
1	Passenger/Right LED "L" Light Bracket	4	6mm x 16mm Hex Bolts
2	Plastic Plugs for license plate mount	4	6mm x 18mm x 1.6 Flat Washers
4	Bracket Spacer Plates	4	6mm Lock Washers
2	12mm Double Nut Plates	5	6mm Button Head Combo Bolt
		1	4mm Wrench

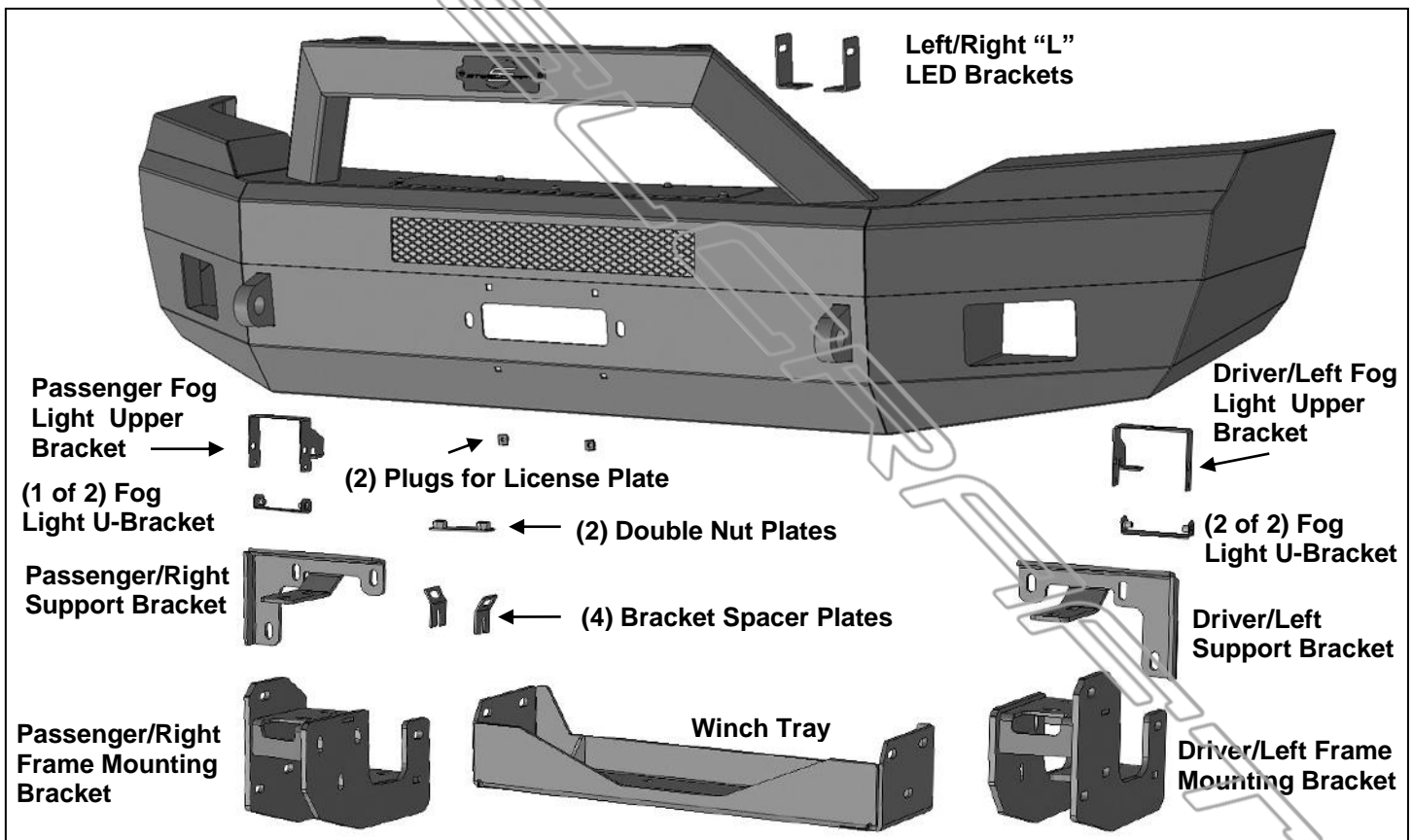

**PROCEDURE:**

**REMOVE CONTENTS FROM BOX. VERIFY ALL PARTS ARE PRESENT. READ INSTRUCTIONS CAREFULLY BEFORE STARTING INSTALLATION. BUMPER IS HEAVY, ASSISTANCE IS HIGHLY RECOMMENDED TO AVOID POSSIBLE INJURY OR DAMAGE TO THE VEHICLE. BUMPER INSTALLATION WILL INTERFERE WITH GRILLE MOUNTED CAMERA. CUTTING MAY BE REQUIRED ON MODELS WITH ECO-BOOST OPTION.**

1. Remove the license plate and bracket. Unplug the harness leading to the bumper, if equipped, and release the harness from the clips attached to the back of the bumper. Move all wiring harnesses away from bumper.

**ELEVATION BULL NOSE FRONT BUMPER  
2018 FORD F150**

2. Next, remove the plastic bumper pad assembly, **(Figure 1)**. **NOTE:** Carefully pull bumper pad straight out away from bumper.
3. Place blocks or jack stands under the front bumper to support it during mounting bolt removal. Once the bumper has been safely supported, remove the large hex nuts from the back of each bumper bracket, **(Figure 2)**. Next, from the front of the bumper, remove the (2) factory hex nuts attaching the bumper to each bumper bracket, **(Figure 3)**. **WARNING!** Assistance is required to hold the bumper in place during bolt removal to prevent the bumper from falling. Carefully slide the bumper off the frame, **(Figure 4)**.
4. Remove the double bolt from the top of the passenger/right bumper mounting flange, **(Figure 4)**. Next, remove the tow hook, (if equipped), from the bottom of the frame. **IMPORTANT:** On models with tow hooks, leave the double nut plate in place inside frame. **NOTE:** Tow hooks cannot be reinstalled.
5. Next, select the passenger/right Frame Mounting Bracket, **(Figure 5)**. Slide the Bracket over the end of the frame. Insert (1) 12mm x 170mm Long Hex Bolt with (1) 12mm Flat Washer through the outside of the mounting tab on the Frame Bracket, through the frame and the inner mounting tab. Secure with (1) 12mm Flat Washer and (1) 12mm Nylon Lock Nut. Insert (1) Spacer Plate down between each mounting tab and the side of the frame, **(Figure 5)**. Do not fully tighten hardware.
6. Attach the Frame Bracket to the bottom of the frame.
  - a. **Model w/o tow hooks**-Insert (1) 12mm Double Nut Plate into the open end of the frame **(Figure 5)**. Attach the Frame Bracket to the bottom of the frame and the Double Nut Plate with (2) 12mm x 50mm Hex Bolts, (2) 12mm Lock Washers and (2) 12mm Flat Washers, **(Figures 5 & 6)**. Leave hardware loose at this time.
  - b. **Model with tow hooks**-Reuse the factory nut plate and hardware to attach the Frame Bracket to the bottom of the frame. Leave hardware loose at this time.
7. Select the passenger/right Frame Support Bracket, **(Figure 7)**. Place the Support Bracket on top of the Frame Mounting Bracket. Attach the Support Bracket directly to the top of the Frame Bracket with (2) 12mm x 50mm Hex Bolts, (4) 12mm Flat Washers and (2) 12mm Nylon Lock Nuts, **(Figure 7)**. Next, attach the Support Bracket to the bumper mounting flange on the frame with the included (3) 12mm x 50mm Hex Bolts, (6) 12mm Flat Washers and (3) 12mm Nylon Lock Nuts, **(Figures 7 & 8)**. Do not fully tighten hardware at this time.
8. Repeat **Steps 4—7** to install the driver/left side Frame and Support Bracket assembly.
9. **Optional Winch Tray and Winch installation (winch sold separately):**
  - a. Select the Winch Tray. With assistance, slide the Winch Tray between the Frame Brackets. Attach the Winch Tray to the Frame Brackets with (6) 12mm x 50mm Hex Bolts, (12) 12mm Flat Washers and (6) 12mm Nylon Lock Nuts, **(Figures 9 & 10)**. Snug but do not fully tighten all hardware. **IMPORTANT: LED bar style light cannot be installed with Winch Tray. If installation of LED bar style light is desired, do not install the Winch Tray and skip to Step 10. Eco-boost air intake shroud may require cutting to clear Winch Tray.**
  - b. If installing winch, follow manufacturer's instructions to attach the winch to the Winch Tray. Winch must be installed before Bumper is placed in position against Brackets. Attach winch cable guide, (not included), to Bumper assembly. Follow manufacturer's instructions to properly wire the winch to the electrical system.
10. Remove fog lights, (if equipped), and wiring harness from factory bumper. Install factory wiring harness into Bumper assembly.
11. **Optional Center LED light installation (sold separately). NOTE:** Light must be installed before Bumper Assembly is attached to the Frame Brackets. **IMPORTANT: Winch Tray cannot be installed with LED bar style light assembly. LED bar style light installation not recommended on models equipped with Eco-boost engine option.**
  - a. Select the L/R "L" Brackets, **(Figure 11)**. **NOTE:** "L" Brackets are offset for universal fitment for most LED bar style lights. Attach the LED light assembly to the "L" Brackets with the included (2) 8mm x 16mm Hex Bolts, (2) 8mm Lock Washers and (2) 8mm Flat Washers. Do not fully tighten hardware at this time. **NOTE:** "L" Brackets may require modification for hardware larger than 8mm or use brackets supplied with light if possible.
  - b. Attach the light and Brackets to the top of the (2) tabs on the back of the Bumper with the included 8mm x 25mm Hex Bolts, (4) 8mm Flat Washers, (2) 8mm Lock Washers and (2) 8mm Hex Nuts, **(Figure 11)**. Adjust light position and tighten hardware.

**ELEVATION BULL NOSE FRONT BUMPER  
2018 FORD F150**

- c. Follow light manufacturer's instructions to wire the light once Bumper has been fully installed.
12. With assistance, position the Bumper Assembly up to and over the Frame Brackets. Temporarily support the weight of the Bumper. **WARNING:** To avoid possible injury or damage to the vehicle, do not proceed until the bumper is fully and safely supported.
13. Line up the (3) holes in the passenger/right Frame Bracket with the (3) holes in the inner mounting plate on the back of the Bumper. Attach the Bumper to the Bracket with the included (3) 12mm x 50mm Hex Bolts, (6) 12mm Flat Washers and (3) 12mm Nylon Lock Nuts, **(Figures 12 & 13)**. Snug but do not tighten hardware at this time. Repeat this **Step** to attach the driver/left side of the Bumper.
14. Level and adjust the bumper and fully tighten all 12mm hardware to 65-70ft-lbs. Access hardware at the top of the Mounting Bracket through the removable access cover on the top of the Bumper. **NOTE:** If additional adjustment is required, loosen Frame Bracket Hardware and adjust Bracket as necessary.
15. **Models with factory fog lights:**
- a. Use a flat blade screwdriver to carefully pop out the tabs on the side of the fog light bracket attaching the light to the bracket. Pop the light out of the plastic bracket housing.
- b. Remove the adjustment screw and spring from the light assembly.
- c. Select the driver/left top U Bracket, **(Figure 14)**. Attach the Bracket to the slot in the light opening with the included (1) 8mm x 20mm Hex Bolt, (2) 8mm Flat Washers and (1) 8mm Nylon Lock Nut, **(Figure 14)**.
- d. Carefully spread the sides of the Bracket enough to slide the OE plastic fog light between and into the Bracket, **(Figure 15)**. Select (1) Lower U-Bracket. Attach the Lower Bracket to the Upper Bracket with (2) 6mm x 16mm Hex Bolts, (2) 6mm Lock Washers and (2) 6mm x 12mm Small Flat Washers, **(Figure 16)**.
- e. Insert the factory spring between the tab on the Bracket and the light. Insert the screw through the tab, spring and into the fog light, **(Figure 16)**.
- f. Repeat to install the passenger/right fog light.
- g. Reattach the wiring harness. Adjust lights as necessary and tighten all fog light bracket hardware.
16. Use the included (2) push-in plastic nuts to attach the front license plate, (if required), to the (2) holes in the front bumper, **(Figure 17)**.
17. Do periodic inspections to the installation to make sure that all hardware is secure and tight.

**To protect your investment**, wax this product after installing. Regular waxing is recommended to add a protective layer over the finish. Do not use any type of polish or wax that may contain abrasives that could damage the finish. Mild soap may be used to clean the Front Bumper assembly.

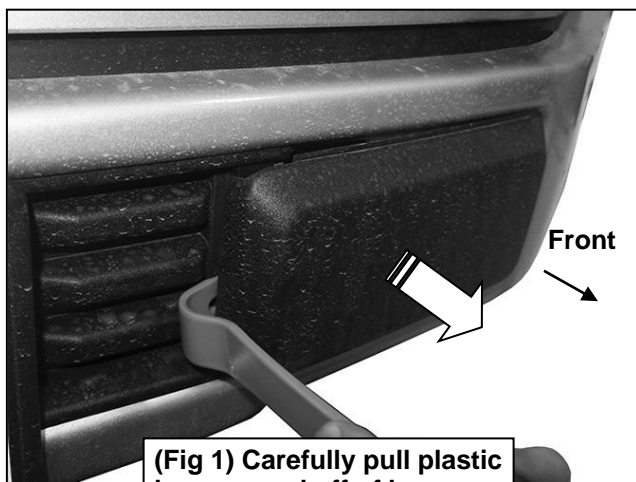

**(Fig 1) Carefully pull plastic bumper pad off of bumper**

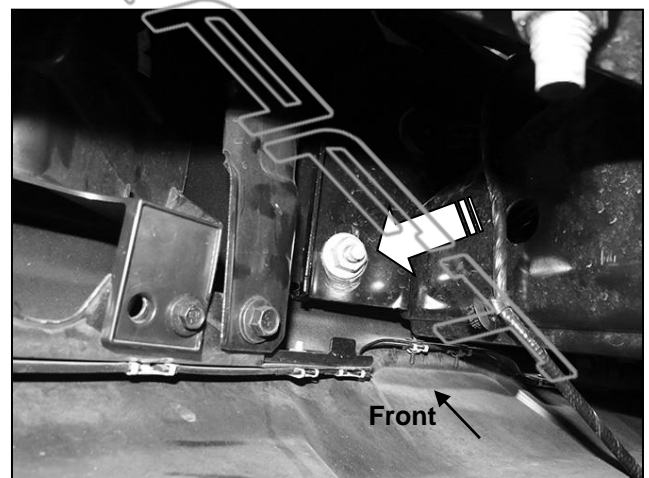

**(Fig 2) Remove factory hex nut (arrow) from back of bumper bracket (Driver side pictured)**

Passenger/right Side Installation Pictured

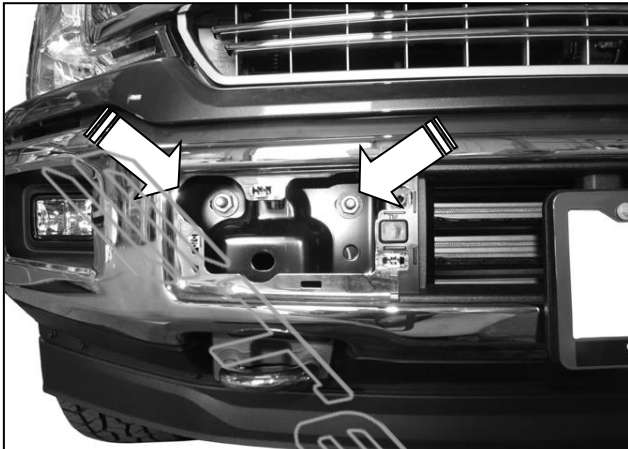

(Fig 3) Remove (2) factory hex nuts from each side



(Fig 4) Remove the tow hooks and plastic seals, (if equipped)

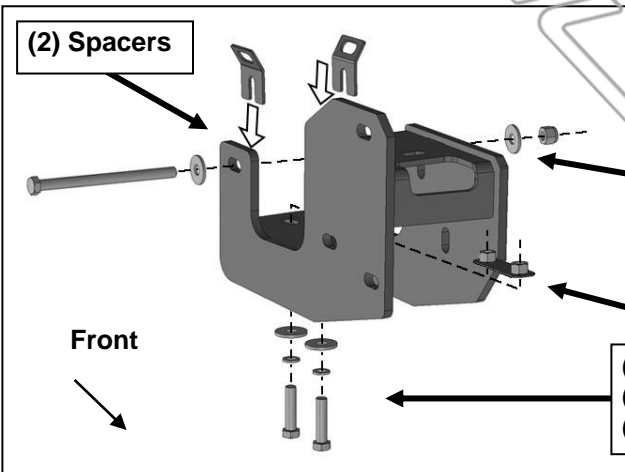

**WARNING!** Do not remove bumper bolts unless the bumper is properly supported on blocks or stands or the bumper may fall.

12mm x 170mm Long Hex Bolt  
(2) 12mm Flat Washers  
12mm Nylon Lock Nut

Double Nut Plate

(2) 12mm x 50mm Hex Bolts  
(2) 12mm Lock Washers  
(2) 12mm Flat Washers

(Fig 5) Insert Spacers between tabs on Bracket assembly and sides of frame. Insert 12mm Double Nut Plate into frame. Attach Frame Bracket to bottom of frame

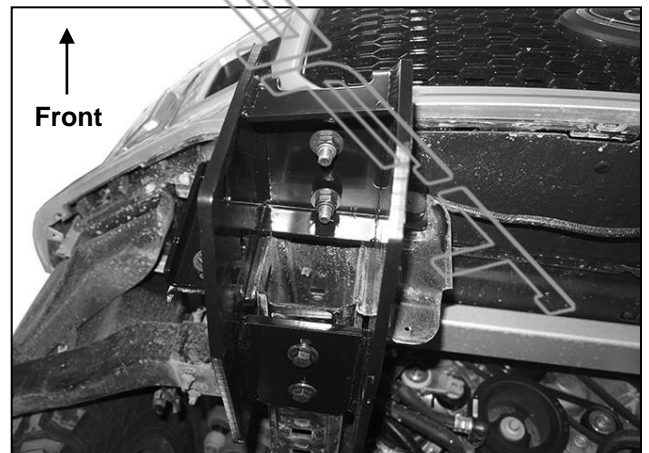

(Fig 6) Passenger/right Frame Bracket attached to bottom of frame and Double Nut Plate

Passenger/right Side Installation Pictured

- (2) 12mm x 50mm Hex Bolts
- (4) 12mm Flat Washers
- (2) 12mm Nylon Lock Nuts

- (3) 12mm x 50mm Hex Bolts
- (6) 12mm Flat Washers
- (3) 12mm Nylon Lock Nuts

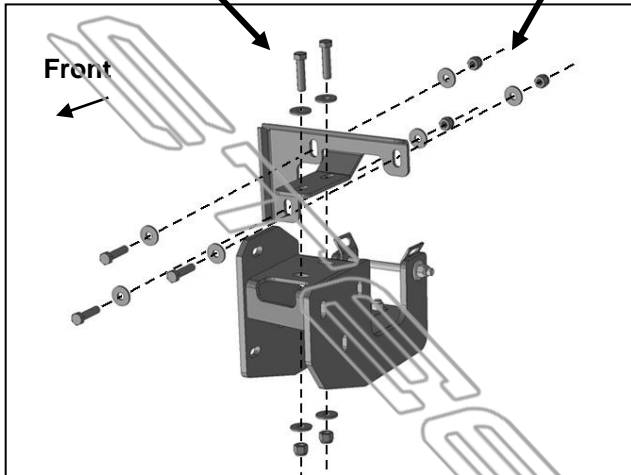

(Fig 7) Attach Support Bracket to bumper mounting plate on frame and to top of Frame Bracket

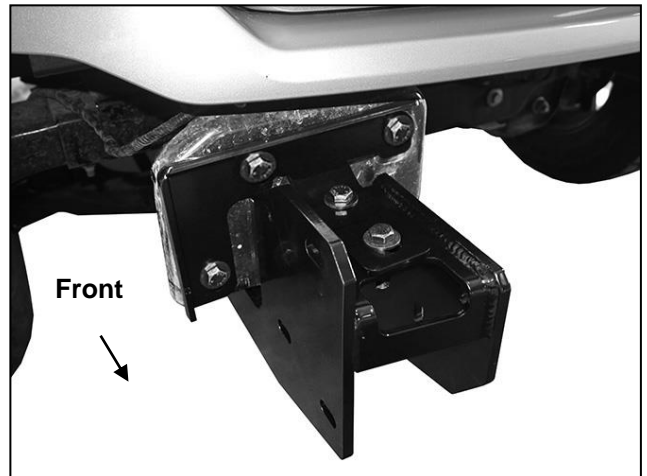

(Fig 8) Passenger/right Frame Bracket and Support Bracket installed. Frame Bracket installed. If winch will not be installed, skip Figures 9 & 10

- (3) 12mm x 50mm Hex Bolts
- (6) 12mm Flat Washers
- (3) 12mm Nylon Lock Nuts

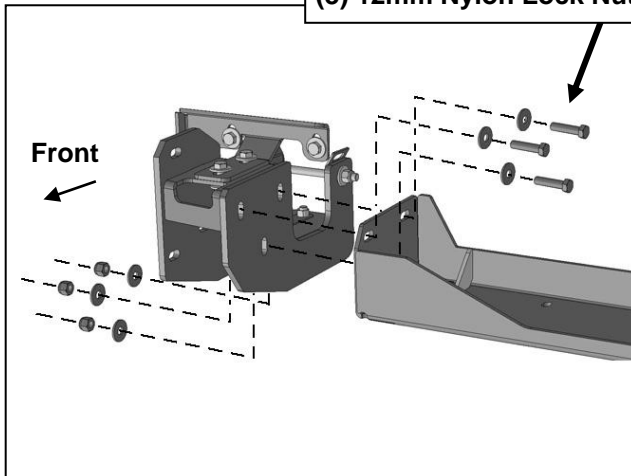

(Fig 9) Attach Winch Tray to Frame Brackets

**IMPORTANT:** Air intake shroud on Ecoboost equipped models may require cutting to clear the Winch Tray.

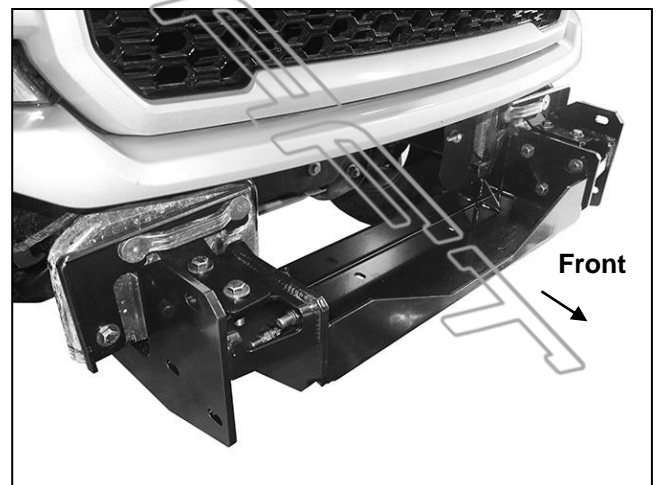

(Fig 10) Attach Winch Tray to Brackets

Passenger/right Side Installation Pictured

8mm x 16mm Hex Bolt  
8mm Lock Washer  
8mm Flat Washer

8mm x 25mm Hex Bolt  
(2) 8mm Flat Washers  
8mm Lock Washer  
8mm Hex Nut

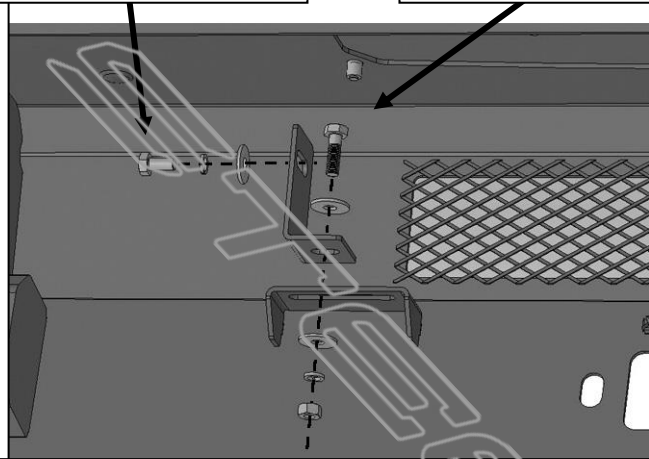

(Fig 11) Universal LED Brackets (light not included)

**WARNING!** Do not crawl under bumper unless the bumper is properly supported on blocks or stands or the bumper may fall.

(3) 12mm x 50mm Hex Bolts  
(6) 12mm Flat Washers  
(3) 12mm Nylon Lock Nuts

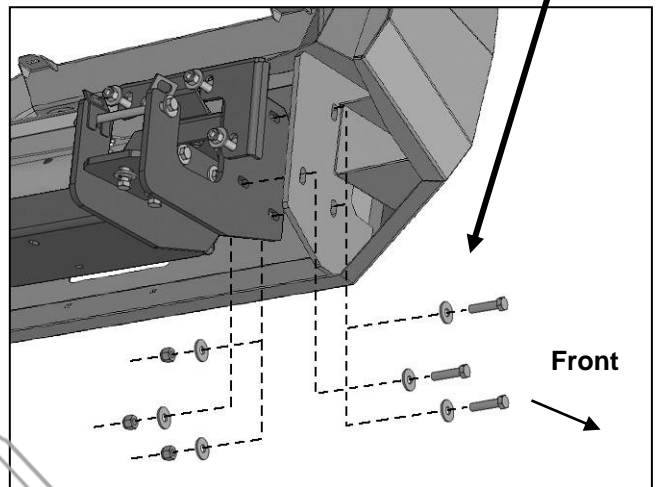

(Fig 12) Attach Bumper to Bracket Assembly

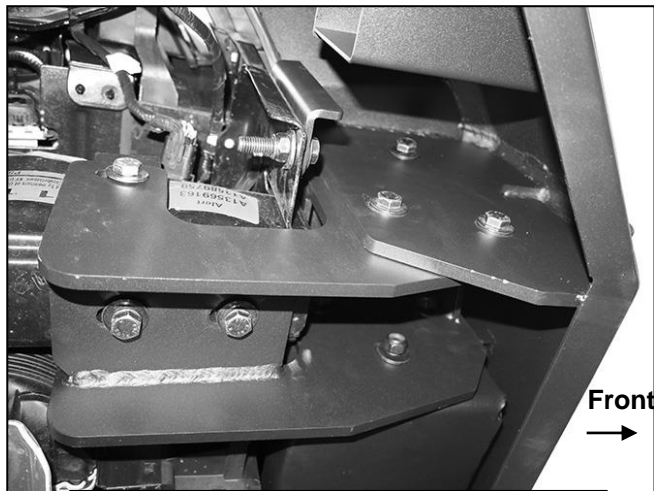

(Fig 13) Passenger/right side of Bumper attached to Bracket assembly, (pictured from behind and below Bumper)

8mm x 20mm Hex Bolt  
(2) 8mm Flat Washers  
8mm Nylon Lock Nut

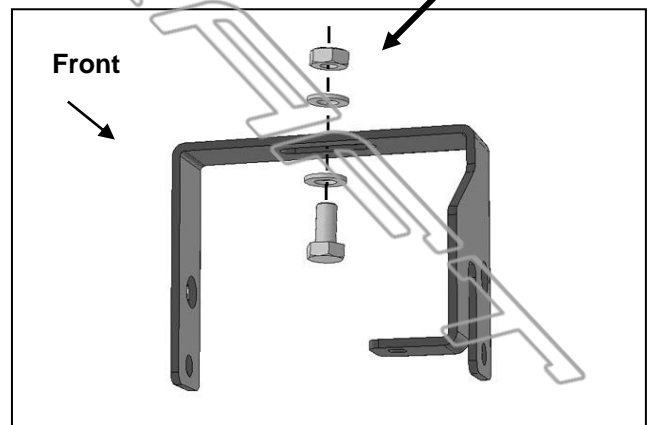

(Fig 14) Optional OEM fog light installation (light not included). Attach driver/left Upper Bracket to the slot in top of the opening

Passenger/right Side Installation Pictured

