

INSTALLATION INSTRUCTIONS

**FORTIS REAR BUMPER
2014-19 TUNDRA**

PARTS LIST:

1	Fortis Rear Bumper	8	12mm x 37mm x 3mm Flat Washers
1	Driver/Left Frame Bracket	4	12mm Nylon Lock Nuts
1	Passenger/Right Frame Bracket	2	8mm x 25mm Hex Bolts
1	Driver/Left Support Bracket	4	8mm x 16mm x 1.6mm
1	Passenger/Right Support Bracket	2	8mm Lock Washers
4	Sensor Plugs	2	8mm Hex Nuts
1	Cover Kit	6	6mm x 30mm Button Head Bolts
8	4mm x 10mm Button Head Bolts	12	6mm x 12mm x 1.6mm Flat Washers
2	License Plate Plugs	6	6mm Lock Washers
2	Plastic BSS Covers	6	6mm Hex Nuts
1	Driver/Left BSS Bracket	6	5mm x 16mm Button Head Bolts
1	Passenger/Right BSS Bracket	6	5mm Lock Washers
8	14-1.5mm x 55mm Fine Thread Hex Bolts	6	5mm x 10mm x 1mm Flat Washers
16	14mm x 28mm x 2.5mm Flat Washers	1	5mm Allen Wrench
8	14mm Lock Washers	1	3mm Allen Wrench
8	14mm Fine Thread Hex Nuts	1	2.5mm Allen Wrench
4	12mm x 45mm Hex Bolts		

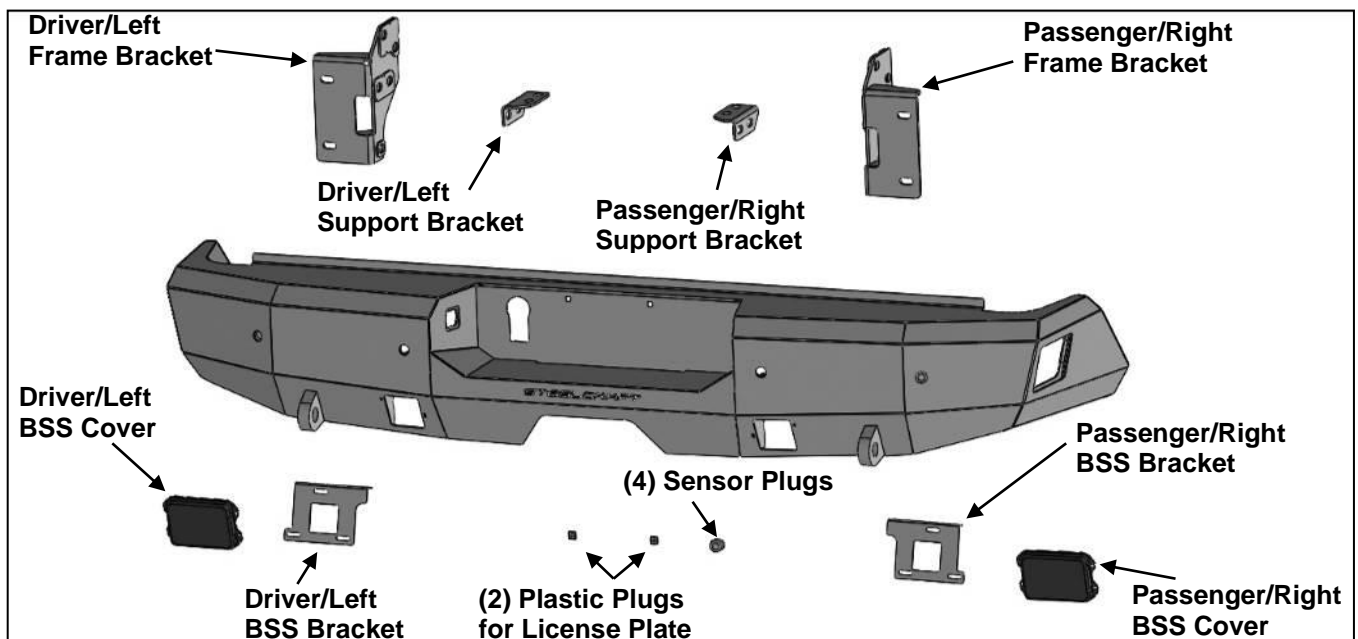

PROCEDURE:

REMOVE CONTENTS FROM BOX. VERIFY ALL PARTS ARE PRESENT. READ INSTRUCTIONS CAREFULLY BEFORE STARTING INSTALLATION. BUMPER IS HEAVY, ASSISTANCE IS RECOMMENDED TO AVOID POSSIBLE INJURY OR DAMAGE TO THE VEHICLE.

1. Begin at the rear of the vehicle. Remove the license plate from the bumper. Unplug the wiring harness leading to the rear bumper (**Figure 1**). Move all wiring harnesses away from bumper.
2. **Determine if vehicle is equipped with a factory receiver hitch**
 - Models without Factory Receiver Hitch**
 - a. Place blocks or jack stands under the bumper to support it during factory bolt removal. Once the bumper has been safely supported, remove the factory hardware attaching the bumper to the frame, (**Figure 2**). Remove Bumper from the frame.
 - b. Select the Driver/Left Support Bracket. Attach the bracket to the bottom of the frame with (2) factory bolts, (**Figure 7 & 8**).

- c. Next, select the Driver/Left Mounting Bracket. Attach the bracket to the outside of the frame and support bracket with (4) 14mm Hex Bolts, (8) 14mm Flat Washers, (4) 14mm Lock Washers, and (4) 14mm Hex Nuts (**Figure 9—11**). Do not tighten hardware at this time.
- d. Repeat **Steps 2a—2c** to attach the Passenger/Right Support Bracket and the Passenger/Right Mounting Bracket to the frame.

Models with Factory Receiver Hitch

- a. Use a flat blade screwdriver to pry the plastic cover from the top of the rear bumper on the passenger and driver side edge (**Figure 3**).
 - b. Remove the plastic screw under the license plate (**Figure 4**). Release the clips and factory hardware under the passenger and driver side of the bumper and proceed to remove the center plastic cover on the top of the bumper (**Figure 5 & 6**).
 - c. Place blocks or jack stands under the receiver hitch to support it during mounting bolt removal. Once the bumper has been safely supported, remove the factory hardware attaching the bumper to the top and bottom of the receiver hitch and remove the bumper (**Figure 7**). **NOTE:** Leave hitch attached to vehicle.
 - d. Select the Driver/Left Mounting Bracket. Attach the bracket to the receiver hitch with (4) 14mm Hex Bolts, (6) 14mm Flat Washers, (4) 14mm Lock Washers and (2) 14mm Hex Nuts, (**Figure 10 & 11**). Use (1) factory bolt in the top hole in the hitch. Do not tighten hardware at this time. Repeat this **Step** to attach the Passenger/Right Mounting Bracket to the frame.
3. Release the wiring harness from the clips attached to the back of the bumper. Remove all lights and sensors. Mark each sensor and light with location.
 4. Locate the (4) sensor mounting sleeves on the backside of the bumper.

Models with sensors, remove the plastic ring around the sensor, (**Figures 12 & 13**). Insert the sensors into the sleeves. Secure Sensors with (8) 4mm Button Head Bolts.

Models without sensors, insert (4) Sensor Plugs. Secure with (8) 4mm Button Head Bolts, (**Figure 14**).

5. **If LED Lights will be installed (Not included)**. Attach LED Light to the mounting plate on the inside of the bumper, (**Figure 15**).
6. Select (1) Blind Spot Sensor (BSS) Plastic Cover. Attach to the inside of the bumper with (3) 5mm Button Head Bolts, (3) 5mm Lock Washers and (3) 5mm Flat Washers, (**Figure 16**).
7. **Models with BSS sensor.**
 - a. Select the Driver/Left BSS sensor Bracket. Attach the BSS sensor to the bracket with (3) 6mm Button Head Bolts, (6) 6mm Flat Washers, (3) 6mm Lock Washers and (3) 6mm Hex Nuts, (**Figures 17 & 18**).
 - b. Attach the BSS sensor Bracket to the inside of the bumper with (1) 8mm Hex Bolt, (2) 8mm Flat Washers, (1) 8mm Lock Washer and (1) 8mm Hex Nut, (**Figure 19**).
8. Reinstall the wiring harness to the back of the bumper.
9. With assistance, position the Bumper Assembly up to the Mounting Brackets. Temporarily support the weight of the Bumper. **WARNING:** To avoid possible injury or damage to the vehicle, do not proceed until the bumper is fully and safely supported.
10. Attach the Bumper to the Mounting Brackets with the included (4) 12mm Hex Bolts, (8) 12mm Flat Washers and (4) 12mm Nylon Lock Nuts to the back of the bumper, (**Figures 20 & 21**). Do not fully tighten hardware.
11. Level and adjust the bumper and fully tighten all hardware.
12. Reinstall the trailer plug, (**Figure 22**). **NOTE:** Use a flat blade screwdriver to carefully pry the metal clip on the plug out to grab the edge of the opening.
13. Insert (2) License Plate Plugs into the holes in the bumper. Insert the License Plate Lights into the square holes in the license plate area of bumper, (**Figure 22**).
14. Reattach the wiring harnesses.
15. Do periodic inspections to the installation to make sure that all hardware is secure and tight.

To protect your investment, Do not use any type of polish or wax that may contain abrasives that could damage the finish. Mild soap may be used to clean the Bumper assembly.



(Fig 1) Unplug and remove 7-wire trailer plug, unplug license plate lights and sensors if equipped

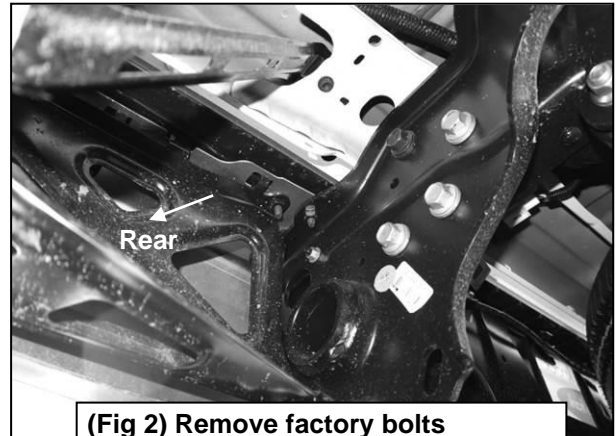

(Fig 2) Remove factory bolts attaching bumper assembly to frame



(Fig 3) Use a flat blade screwdriver to pry the plastic cover from the top of edges of the bumper

WARNING! Do not remove bumper bolts unless the bumper is properly supported on blocks or stands or the bumper may fall.

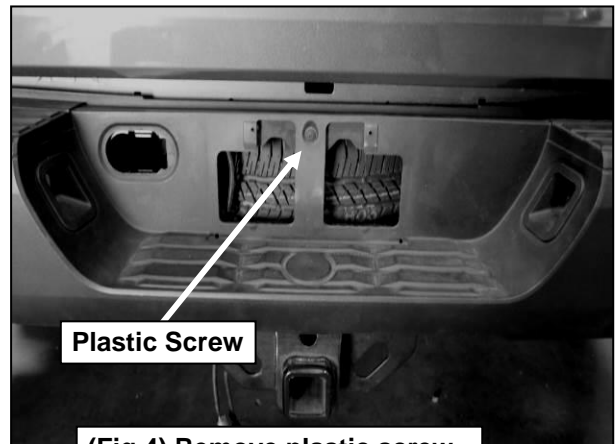

(Fig 4) Remove plastic screw under the license plate.

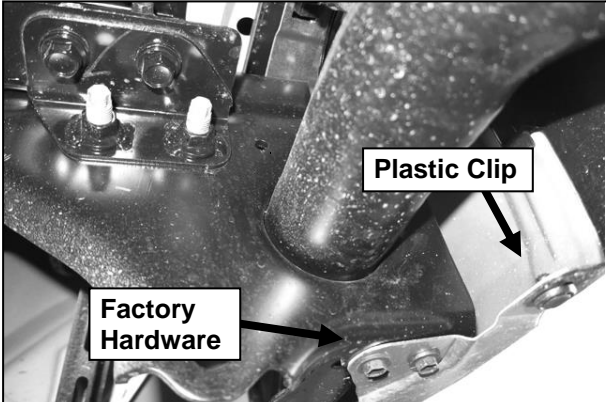

(Fig 5) Remove Factory Hardware and Plastic Clip from the underside of the bumper



(Fig 6) Remove plastic cover from the top of the bumper

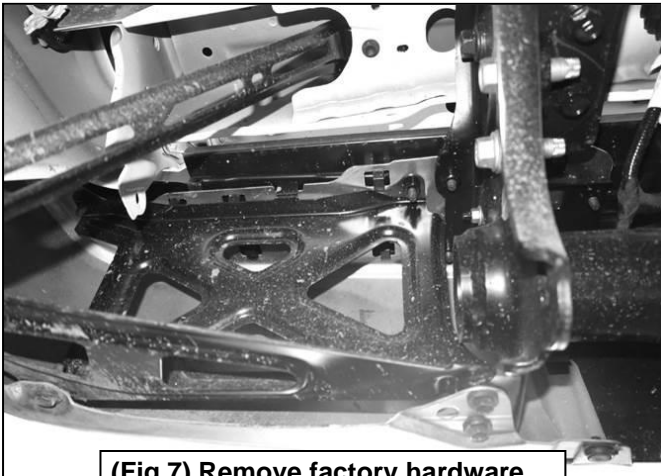

(Fig 7) Remove factory hardware under the plastic pieces.

Note: The support brackets that come with the kit install in the same place factory support brackets would be installed.

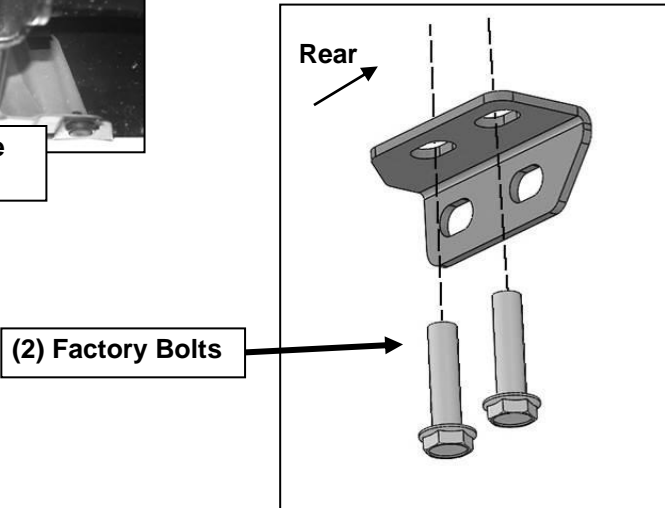

(Fig 8) Attach Driver/Left Support Bracket to frame (Required on models without receiver hitch)



(Fig 9) Driver/Left Frame Mounting Location with the Support Bracket attached (Models without hitch)

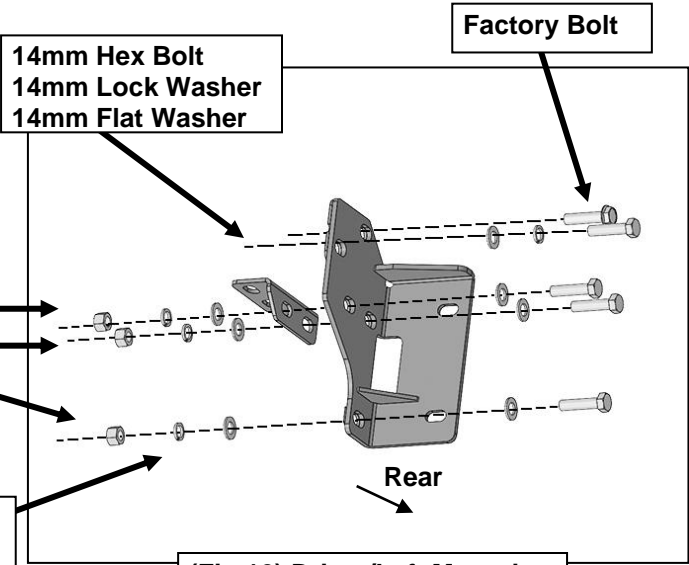

- (3) 14mm Hex Bolts
- (6) 14mm Flat Washers
- (3) 14mm Lock Washers
- (3) 14mm Hex Nuts

Lower bolt is only used if the vehicle is equipped with a hitch

(Fig 10) Driver/Left Mounting Bracket to Hitch Plate

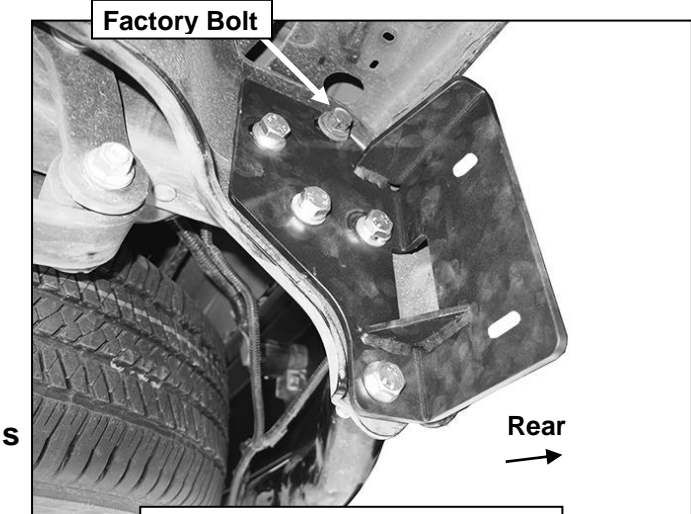

(Fig 11) Driver/Left Mounting Bracket to Hitch Plate installed

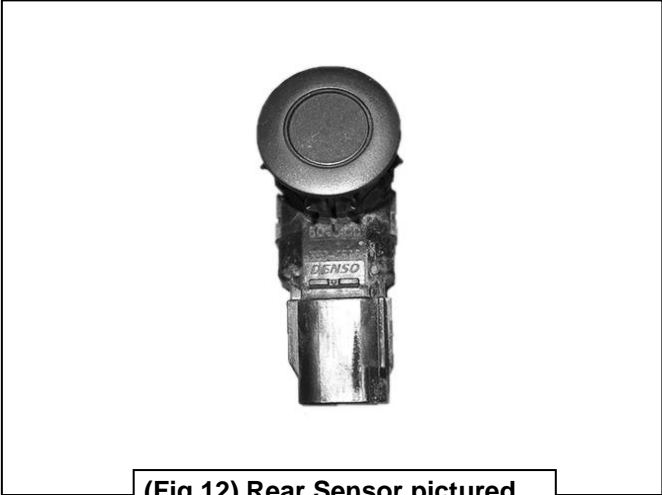

(Fig 12) Rear Sensor pictured



(Fig 13) Rear Sensor with plastic ring removed

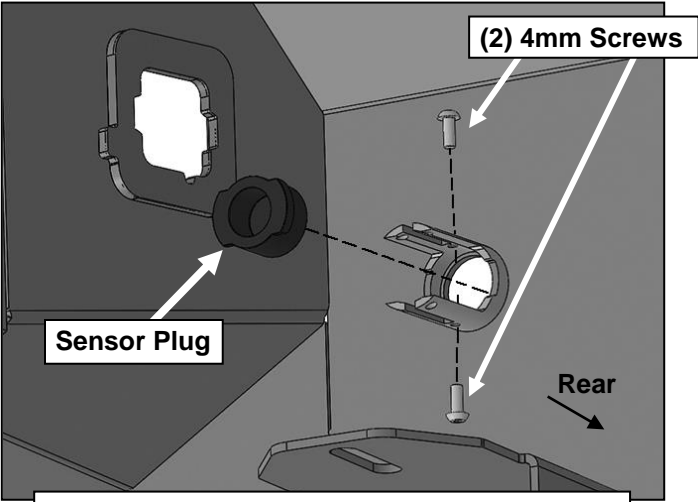

(Fig 14) Push Sensor or Sensor Plug into mounting sleeve. Use 4mm Screws to lock in place. (Sensor Plug installation shown)

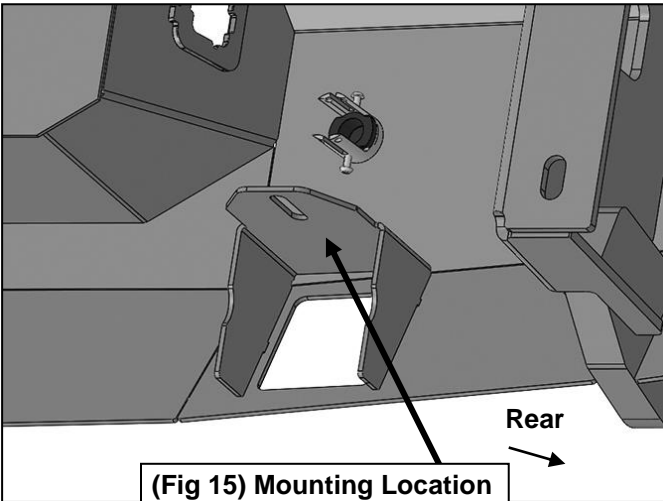

(Fig 15) Mounting Location for Light Installation

- (3) 5mm Button Head Bolts
- (3) 5mm Lock Washers
- (3) 5mm Flat Washers

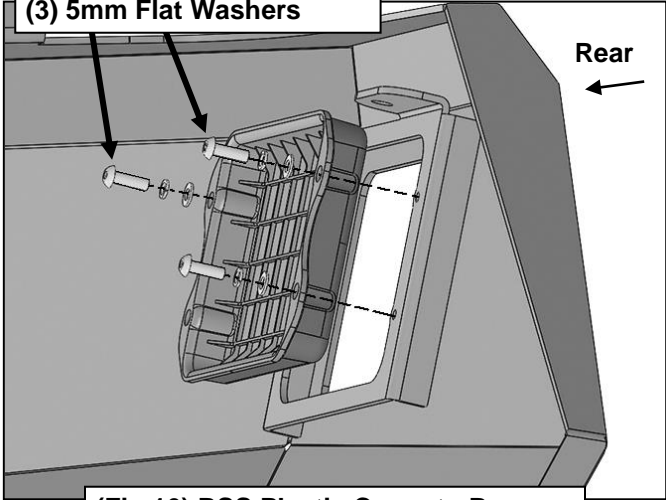

(Fig 16) BSS Plastic Cover to Bumper installation (Driver/Left shown)

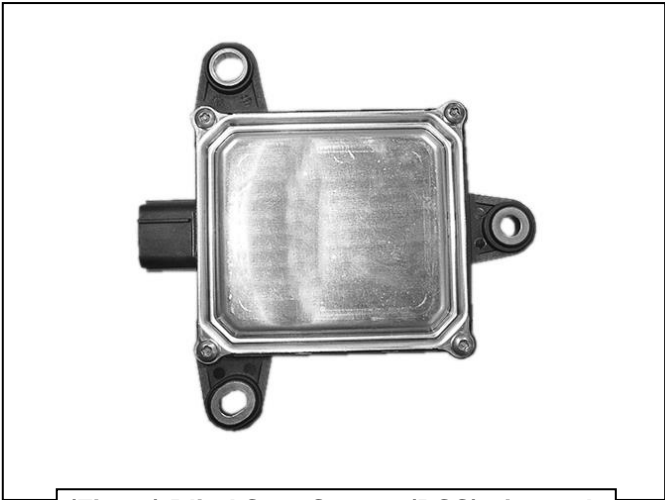

(Fig 17) Blind Spot Sensor (BSS) pictured

- (3) 6mm Button Head Bolts
- (6) 6mm Flat Washers
- (3) 6mm Lock Washers
- (3) 6mm Hex Nuts

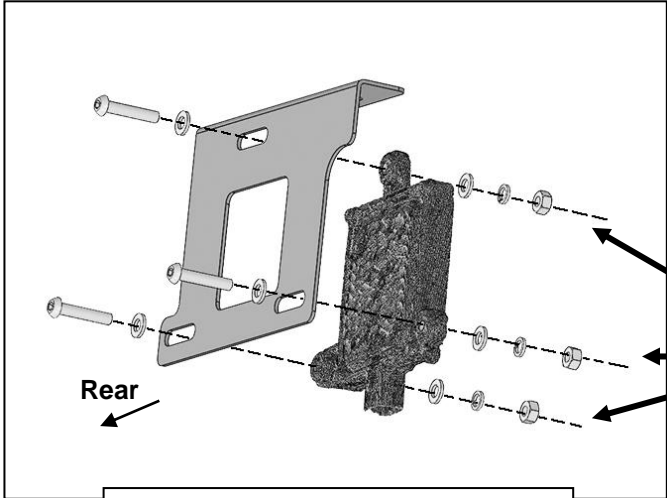

(Fig 18) Driver/Left BSS installation

- 8mm Hex Bolt
- (2) 8mm Flat Washers
- 8mm Lock Washer
- 8mm Hex Nut

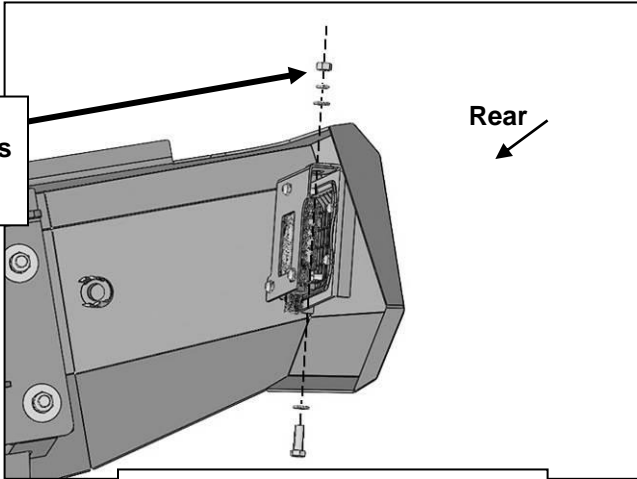

(Fig 19) Driver/Left BSS Bracket to Bumper installation

**FORTIS REAR BUMPER
2014-19 TUNDRA**

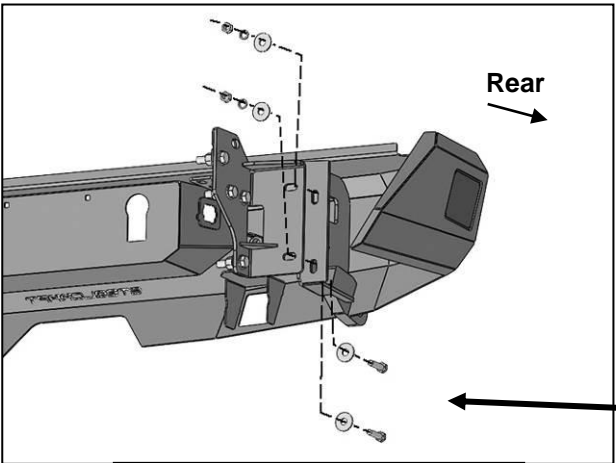

WARNING! Do not crawl under bumper unless the bumper is properly supported on blocks or stands or the bumper may fall.

- (2) 12mm Hex Bolts
- (4) 12mm Flat Washers
- (2) 12mm Lock Washers
- (2) 12mm Hex Nuts

(Fig 20) Bumper to Driver/Left Mounting Bracket installation

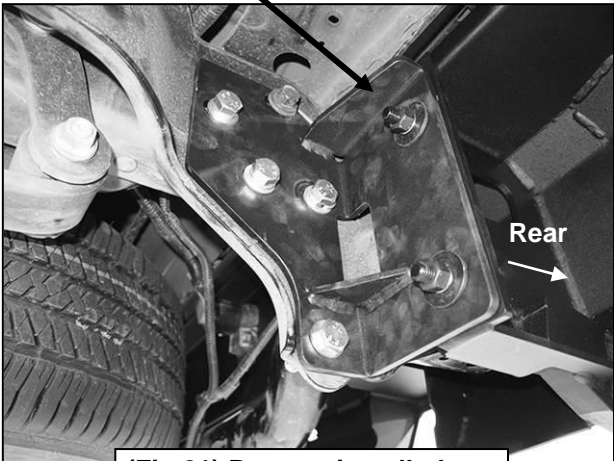

(Fig 21) Bumper installed to Driver/Left Mounting Bracket

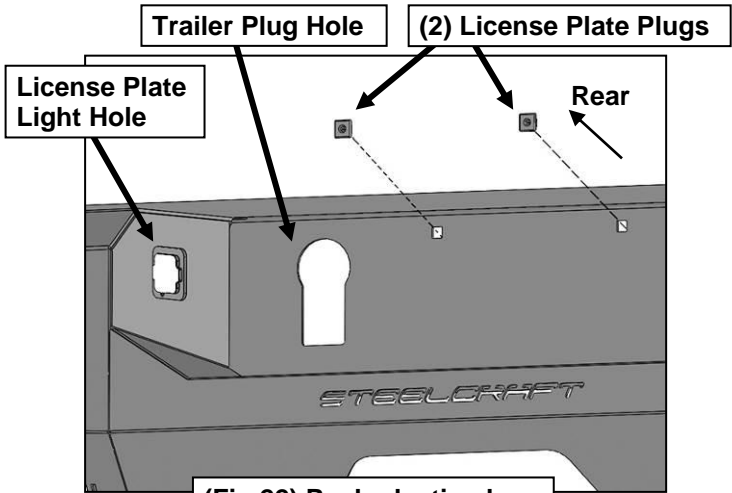

(Fig 22) Push plastic plugs into holes for license plate