

**HD SIDE STEP**  
**07-17 1500-2500-3500 SILVERADO/SIERRA CREW CAB 6.5FT BED WHEEL TO WHEEL**  
**INCLUDES DIESEL W/DEF**

**PARTS LIST:**

1	Driver side HD Side Step	15	8-1.25mm x 25mm Hex Bolts
1	Passenger side HD Side Step	1	8mm x 28mm x 3mm Flat Washer
1	Passenger side DEF Tank Upper Bracket	16	8mm x 24mm x 2mm Flat Washers
15	8-1.25mm Clip-On Nuts	15	8mm Lock Washers
1	8mm Bolt Plate	1	8-1.25mm Nylon Lock Nut
1	8-1.25mm x 40mm Hex Bolt		

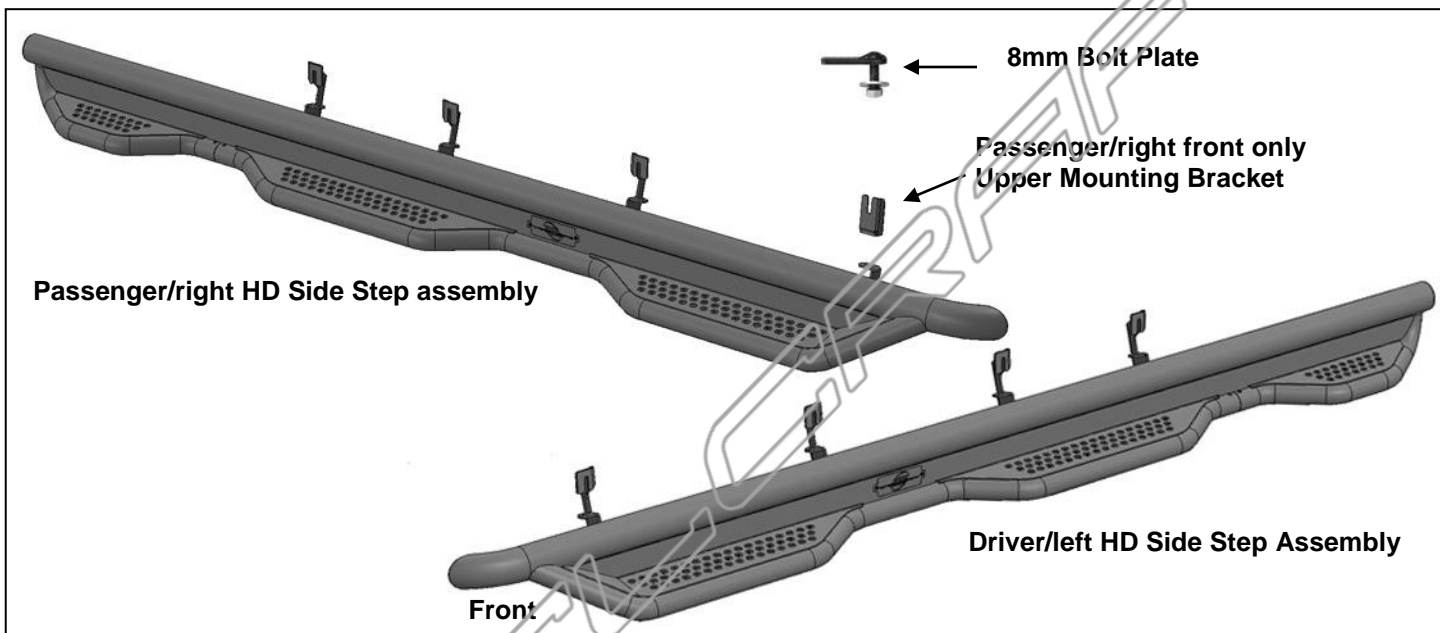

**PROCEDURE:**

**REMOVE CONTENTS FROM BOX. VERIFY ALL PARTS ARE PRESENT. READ INSTRUCTIONS CAREFULLY BEFORE STARTING INSTALLATION. ASSISTANCE IS RECOMMENDED. ON MODELS WITH DEF TANK, SELECT A FLAT, LEVEL AREA FOR INSTALLATION.**

1. Start the installation under the driver side of the vehicle. Locate the 5 tabs along the bottom edge of the body, (pinch weld). Mounting Brackets on Side Step will bolt to the 1st, 2nd, 4th and 5th mounting tabs, **(Figure 1)**. Directly above each tab is a top mounting location on the side of the body panel. If necessary, line up the driver/left HD Side Step with the mounting holes in the body panel to help determine correct locations.

2. Determine the correct procedure for your model year and each Bracket location.

**Bottom mounting location on the edge of the pinch weld.**

**Flat tab on pinch weld with factory installed weld nut:**

Thread hex bolt into weld nut from the backside-down to clear paint from threads, **(Figure 2)**.

**Flat tab on pinch weld with hole:**

Select (1) 8mm Clip Nut. Slide the Clip Nut over the tab with the nut facing up behind the tab, **(Figures 3—5)**. Line up threaded nut with hole in the tab. Repeat for each mounting location.

**Locate top mounting location on the back side of the body panel.**

**Models with factory installed threaded insert in body panel:**

Thread 8mm Hex Bolt into threaded insert to clear paint as required, **(Figures 2 & 3)**.

**Large and small hole in side of body panel:**

Remove the rubber plug from the larger hole, **(Figure 4)**. Select (1) 8mm Clip Nut. Slide the Clip Nut into the larger hole. Line up the threaded nut with the smaller hole, **(Figure 5)**.

3. With assistance, hold the HD Side Step up in position. Attach the mounting tabs on the HD Side Step to the Clip Nuts and/or the factory threaded holes with (8) 8mm Hex Bolts, (8) 8mm Lock Washers and (8) 8mm STD Flat Washers, **(Figures 6 & 7)**.

**HD SIDE STEP  
07-17 1500-2500-3500 SILVERADO/SIERRA CREW CAB 6.5FT BED WHEEL TO WHEEL  
INCLUDES DIESEL W/DEF**

4. Level and adjust the HD Side Step and fully tighten all hardware.
5. Move to the passenger side of the vehicle. On the passenger side, determine if the vehicle is equipped with a plastic diesel exhaust fluid (DEF) tank, **(Figures 8 & 9)**.

**Models without DEF tank, skip to Step 6.**

**Models with DEF tank:** The tank sits close to the side of the body. With specialized tools, the passenger front upper and lower Bracket can be installed but room is limited. It may be easier to drop the tank down to access the inner side of the body panel for Upper Bracket installation. Tank will not need to be removed, only dropped down for access to mounting location. **IMPORTANT:** If tank is full, it will be very heavy and assistance is highly recommended to avoid injury or damage to the vehicle or the tank. It is recommended that installation is performed when the DEF tank is low on fluid before dropping the tank.

- a. On models with plastic lower tray under the tank, remove the (3) hex bolts attaching the tray to the frame, **(Figure 8)**, and remove the tray. **2017 2500/3500 models:** Remove the (4) hex bolts attaching the plastic cover to the DEF tank, **(Figure 9A)** and remove plastic cover, **(Figure 9B)**.
  - b. Release the tank filler hose. Release the plug for the sending unit on the top of the tank.
  - c. Release the tank filler hose. Release the plug for the sending unit on the top of the tank.
  - d. Support the tank with a floor jack. Place a smooth flat surface, (wooden block for example), between the floor jack and the tank to avoid damaging the plastic tank. Do not push up on the tank; only support the weight of the tank with the jack.
  - e. Remove the (2) bolts securing the tank straps to the vehicle, **(Figure 10)**. Tilt the straps to release from the brackets. Slowly lower the tank until the top of the tank is almost visible. Use blocks or stands to support the tank while installing the front Upper Bracket.
6. Locate the first tab on the edge of the pinch weld, **(Figures 2—4, 12 & 13)**. Select the Upper Bracket, **(Figure 11)**. Repeat **Step 2** to attach the passenger/right front Upper Bracket first to the side of the body panel, **(Figure 12)**. Do not tighten hardware at this time.
  7. Line up the hole in the bottom of the Upper Bracket with the hole in the tab on the pinch weld.
    - a. **Models with a weld-nut:** Slide the Bracket over the weld-nut, **(Figure 12)**. Insert (1) 8mm x 40mm Hex Bolt with (1) 8mm x 28mm Large Flat Washer down through the threaded hole in the weld nut and Upper Bracket, **(Figure 17)**. Tighten all hardware attaching Upper Bracket only.
    - b. **Models with flat tab and hole:** Select the 8mm Bolt Plate. Insert the Bolt Plate down through the hole in the Upper Bracket and the mounting tab, **(Figures 13 & 17)**. Leave loose.
  8. Repeat **Step 2** to prepare the 2nd, 4th and 5th mounting locations before installation, **(Figures 2—5)**.
  9. With assistance, hold the HD Side Step up in position. Repeat **Step 3** to attach the HD Side Step to the passenger side 2nd, 4th and 5th mounting locations, **(Figures 6 & 7)**. Do not tighten hardware.
    - a. **2017 2500/3500 DEF tank models:** Locate the 2nd tab bracket location along the bottom edge of the body, (pinch weld), **(Figure 14)**. Hold the DEF cover in place and mark the 2nd Bracket location onto the cover, **(Figure 15)**. Use a sharp knife or hacksaw blade to carefully cut a slot in the plastic cover to clear the 2nd Bracket, **(Figure 16)**. Remove as little plastic as possible.
  10. Line up the front mounting tab on the HD Side Step with the Upper Bracket. Attach the mounting tab to the Hex Bolt or Bolt Plate in the bottom of the body panel with (1) 8mm x 24mm Flat Washer and (1) 8mm Nylon Lock Nut, **(Figure 17)**. Do not tighten hardware at this time.
  11. Level and adjust the HD Side Step and fully tighten all hardware.
  12. Once fully installed and all hardware fully tightened, reinstall the DEF tank and cover, if equipped, as described in **Steps 5 & 9**.
  13. Do periodic inspections to the installation to make sure that all hardware is secure and tight.

**To protect your investment,** wax this product after installing. Regular waxing is recommended to add a protective layer over the finish. Do not use any type of polish or wax that may contain abrasives that could damage the finish. Mild soap may be used to clean the HD Side Step.

Driver/Left Side Installation Pictured

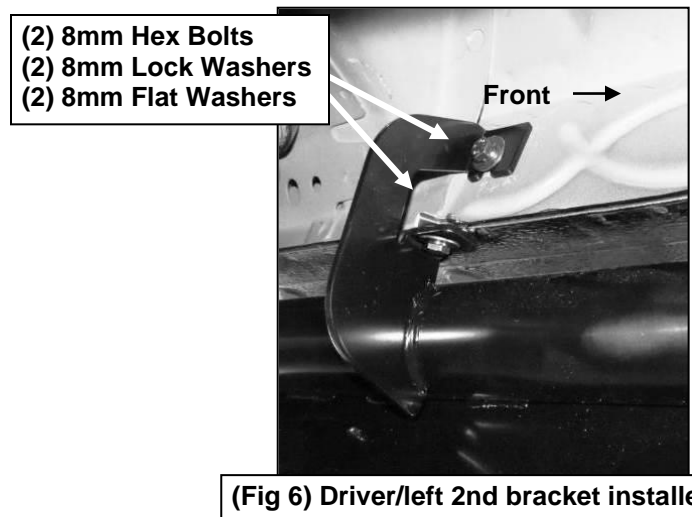
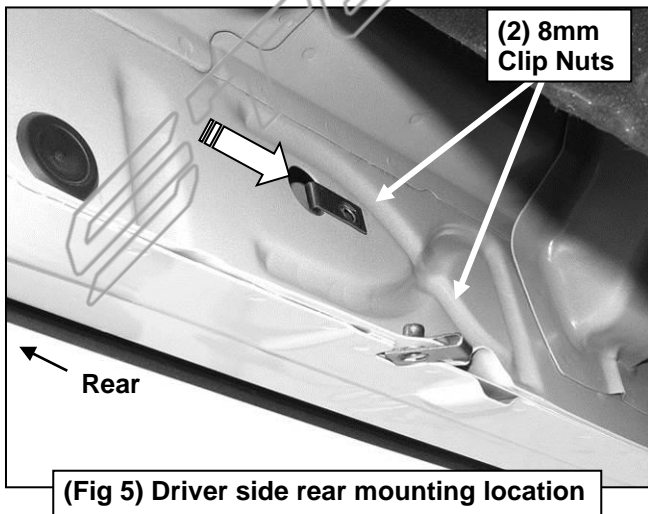
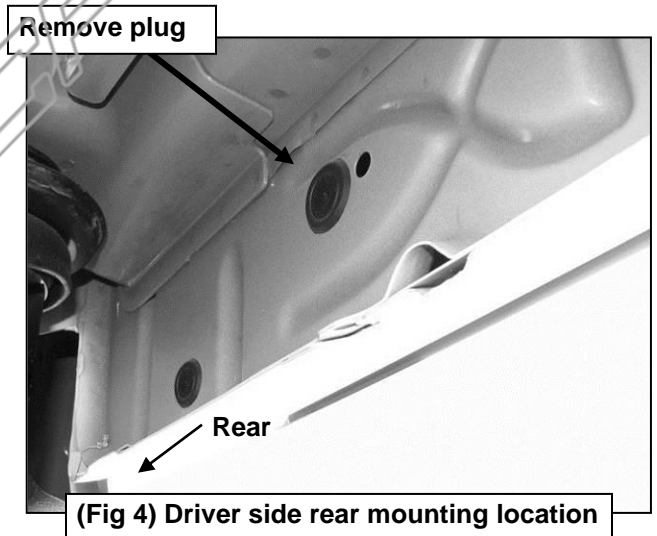
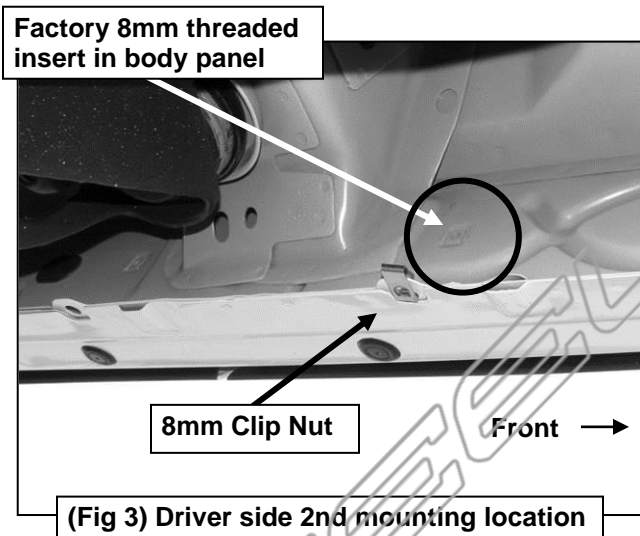
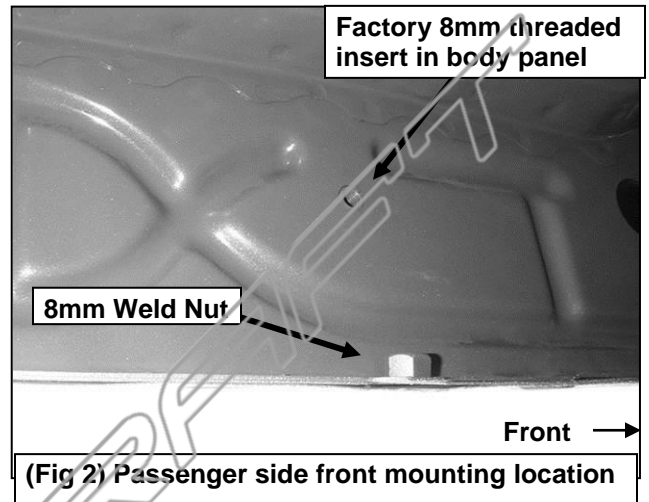
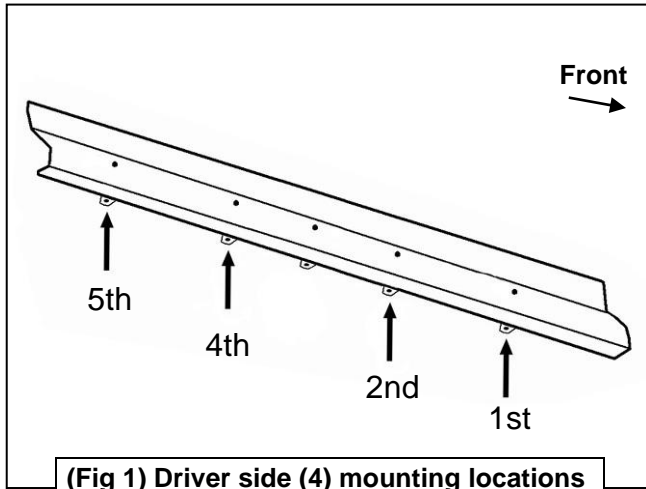

Driver/Left Side Installation Pictured

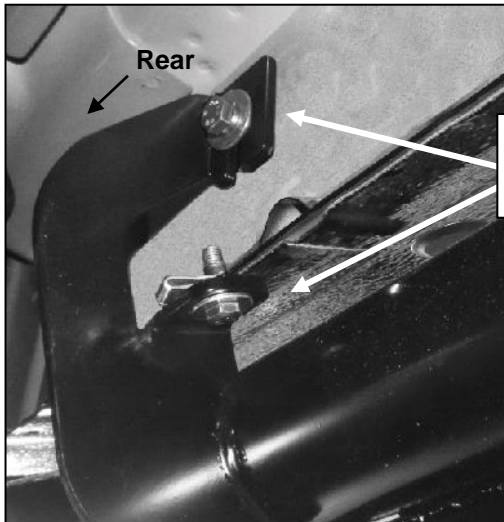

- (2) 8mm Hex Bolts
- (2) 8mm Lock Washers
- (2) 8mm Flat Washers

(Fig 7) Driver/left rear bracket installed

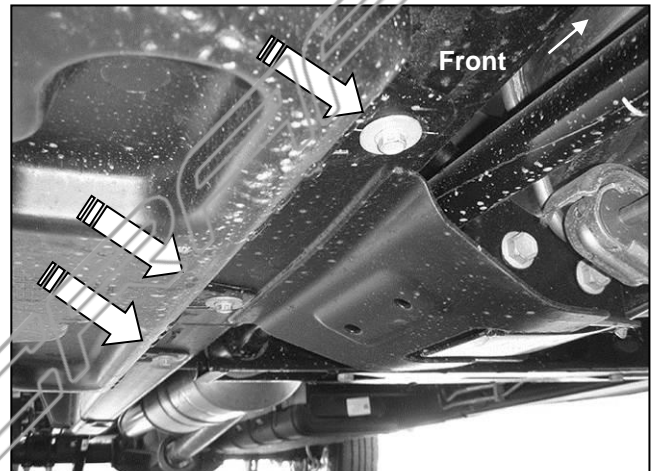

(Fig 8) 07-16 Passenger side front pictured with DEF tank cover. Remove (3) hex bolts to remove cover

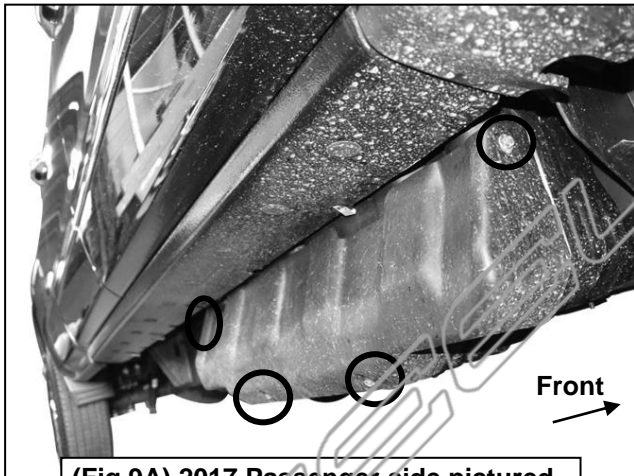

(Fig 9A) 2017 Passenger side pictured with DEF plastic tank cover. Remove (4) hex bolts to remove plastic cover



(Fig 9B) 2017 Passenger side DEF cover

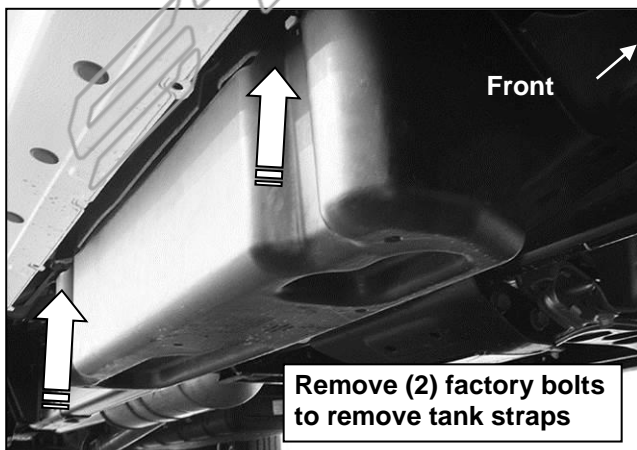

Remove (2) factory bolts to remove tank straps

(Fig 10) 07-16 Passenger side DEF tank and cover

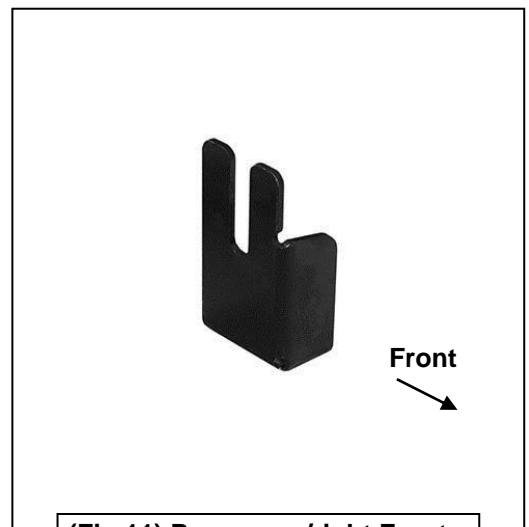

(Fig 11) Passenger/right Front Upper Bracket (all models)

Passenger/right Side Installation Pictured

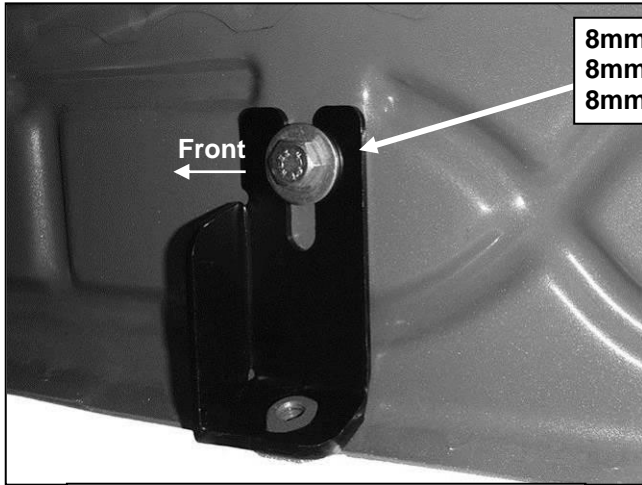

(Fig 12) Slide Upper Bracket over weld nut if equipped-also see Figure 2

On models with flat tab (see Fig 3 & 4), insert 8mm Bolt Plate down through Upper Bracket and mounting tab

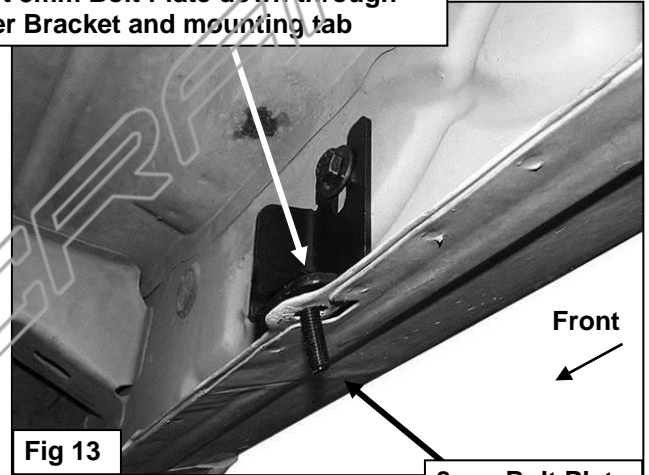
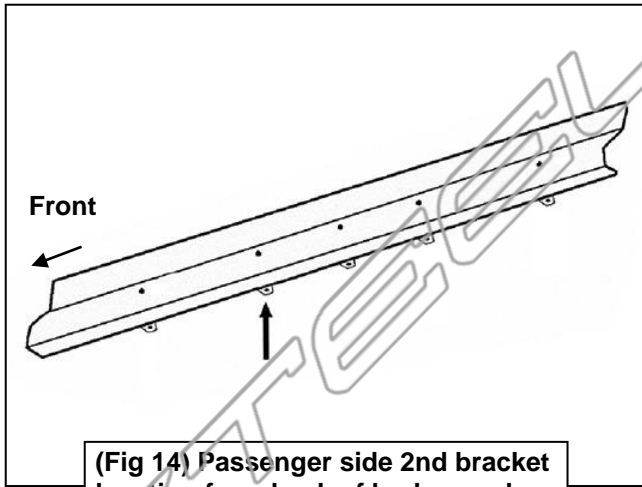

Fig 13

8mm Bolt Plate



(Fig 14) Passenger side 2nd bracket location from back of body panel

mark pictured is approximately 70mm x 10mm

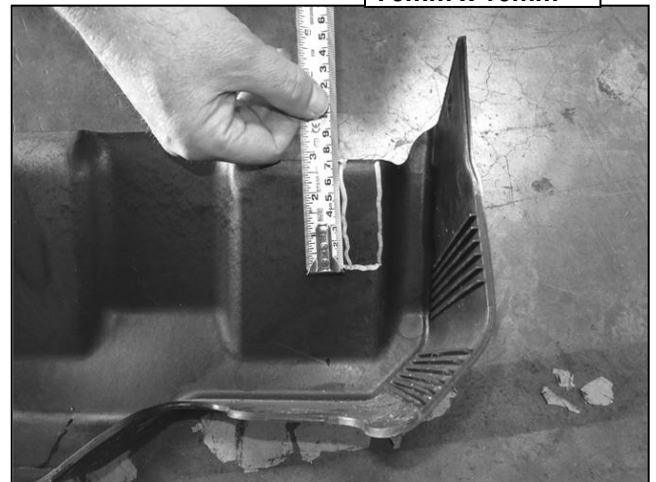

(Fig 15) 2017 Passenger side DEF cover marked for trimming

HD SIDE STEP  
07-17 1500-2500-3500 SILVERADO/SIERRA CREW CAB 6.5FT BED WHEEL TO WHEEL  
INCLUDES DIESEL W/DEF

Passenger/right Side Installation Pictured

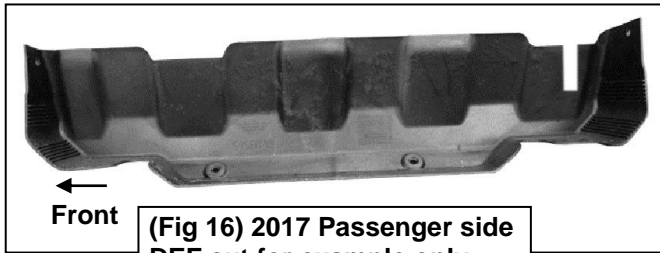

(Fig 16) 2017 Passenger side  
DEF cut for example only



Models with flat tab  
on panel (see Fig 13):  
8mm Bolt Plate

8mm Hex Bolt  
3mm Lock Washer  
8mm STD Flat Washer

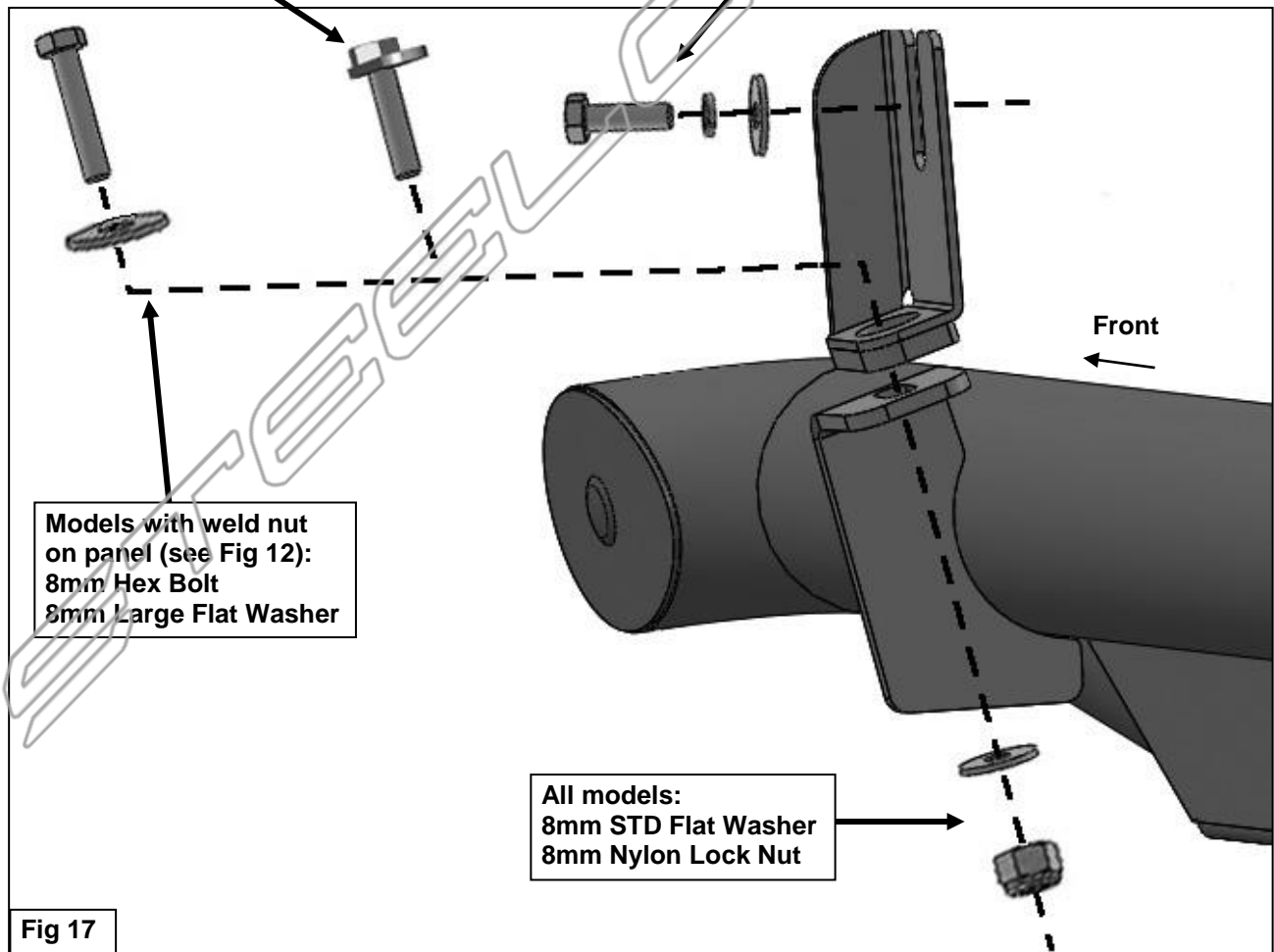

Fig 17