

**HEADACHE RACK  
05-18 TOYOTA TACOMA**

**PARTS LIST:**

1	Headache Rack	4	12mm Hex Nuts
1	Driver/Left Side Bracket	6	10mm Bolt Plates
1	Passenger/Right Side Bracket	6	10mm x 30mm x 2.5mm Flat Washers
4	12mm x 40mm Hex Bolts	6	10mm Lock Washers
8	12mm x 32mm x 3mm Flat Washers	6	10mm Hex Nuts
4	12mm Lock Washers		

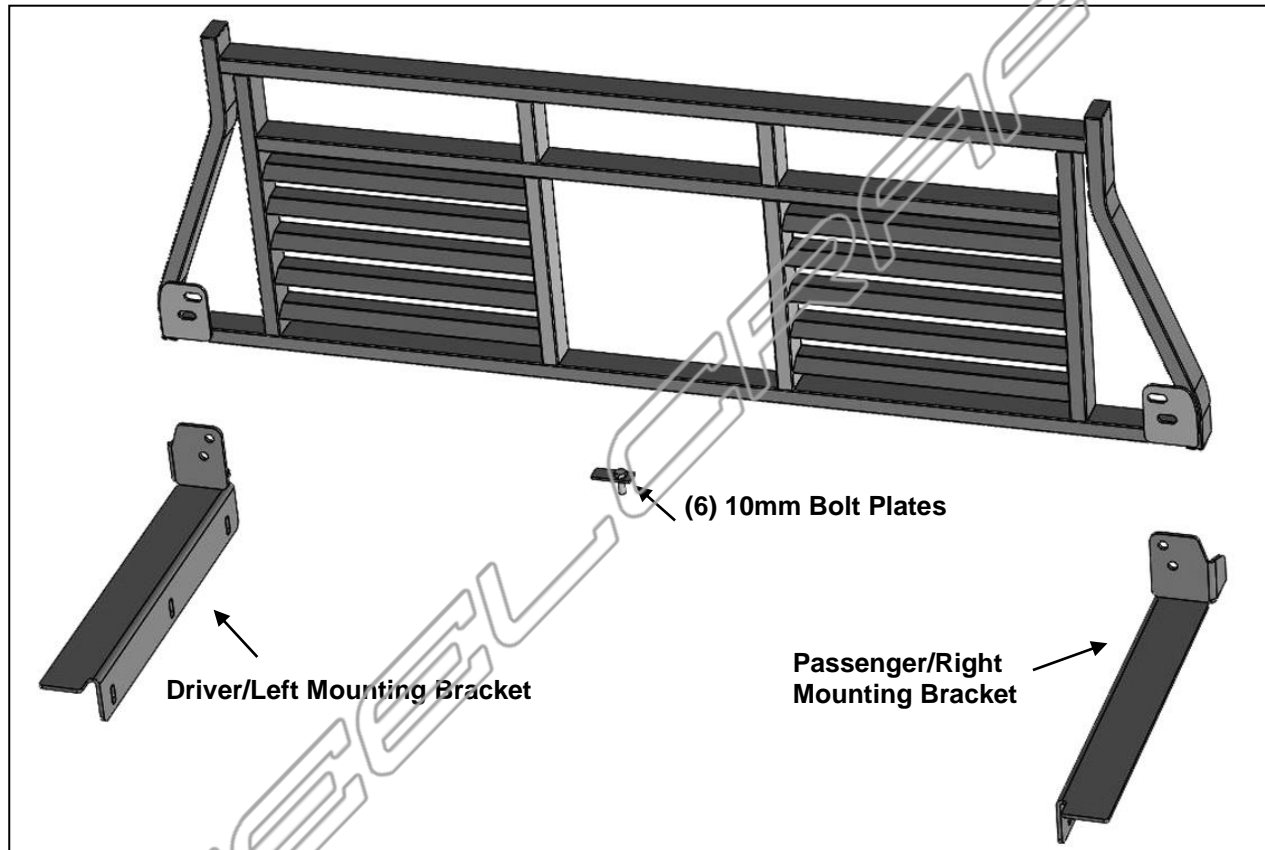

**REMOVE CONTENTS FROM BOX. VERIFY ALL PARTS ARE PRESENT. READ INSTRUCTIONS CAREFULLY BEFORE STARTING INSTALLATION. ASSISTANCE IS RECOMMENDED.**

- Starting at the driver side of the bed rail, **(Figure 1)**, remove all factory hardware along and at the ends of the bed channel, **(Figures 1 & 2)**.
- Select (3) 10mm Bolt Plates. Slide the Bolt Plates through the ends of the bed channel, **(Figures 3 & 4)**. **NOTE:** Place the Bolt Plates approximately 9" apart.
- Select the driver side Bracket. Attach the Bracket to the (3) 10mm Bolt Plates using the included (3) 10mm Flat Washers, (3) 10mm Lock Washers and (3) 10mm Hex Nuts, **(Figure 5)**. Do not tighten hardware at this time.
- Repeat **Steps 1—3** to install the passenger/right side Bracket.
- With assistance, carefully place the Headache Rack onto the front end of the Brackets. Attach the Headache Rack to the Brackets using (4) 12mm Hex Bolts, (8) 12mm Flat Washers, (4) 12mm Lock Washers and (4) 12mm Hex Nuts, **(Figure 6)**. Do not tighten hardware.
- Center the Headache Rack on the truck, check the alignment and tighten all hardware.
- Do periodic inspections to the installation to make sure that all hardware is secure and tight.

**To protect your investment**, wax this product after installing. Regular waxing is recommended to add a protective layer over the finish. Do not use any type of polish or wax that may contain abrasives that could damage the finish.

**HEADACHE RACK  
05-18 TOYOTA TACOMA**

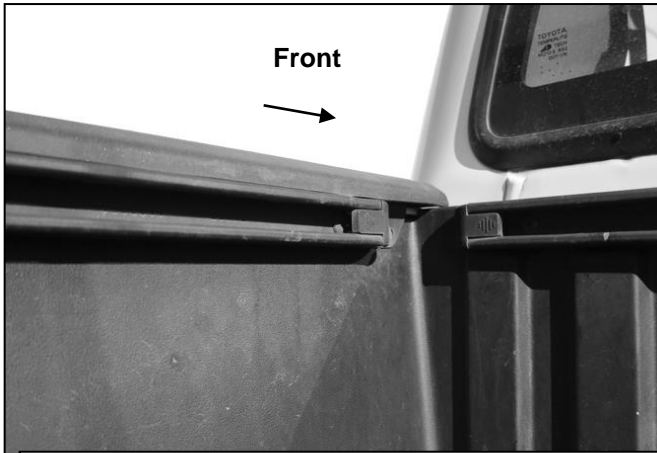

**(Fig 1) Remove factory hardware attached to the ends of the bed channel (Driver side pictured)**

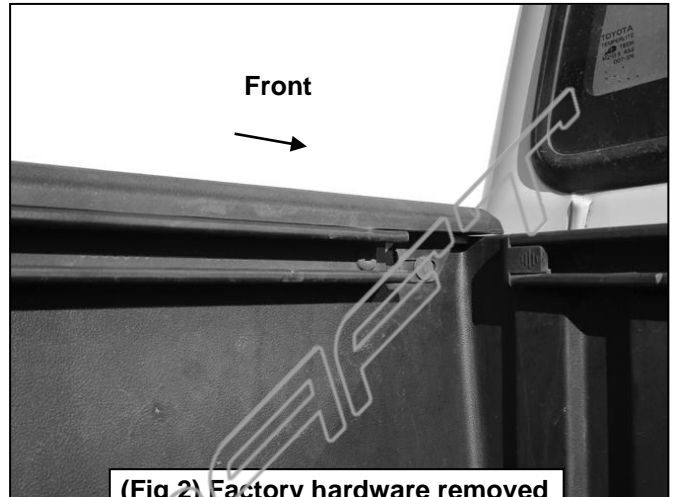

**(Fig 2) Factory hardware removed**

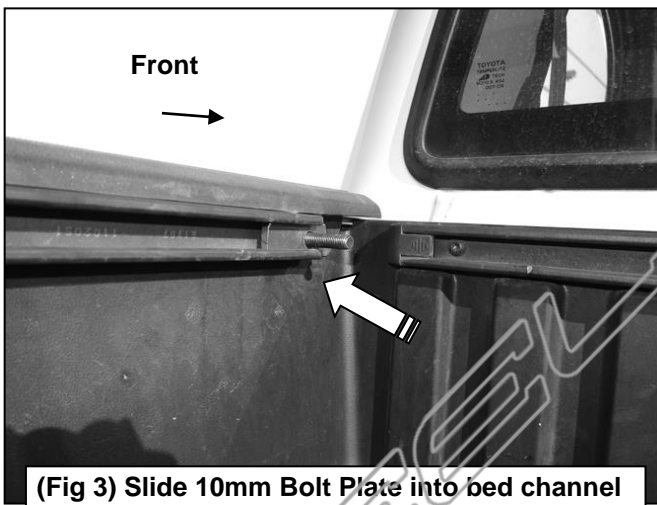

**(Fig 3) Slide 10mm Bolt Plate into bed channel**

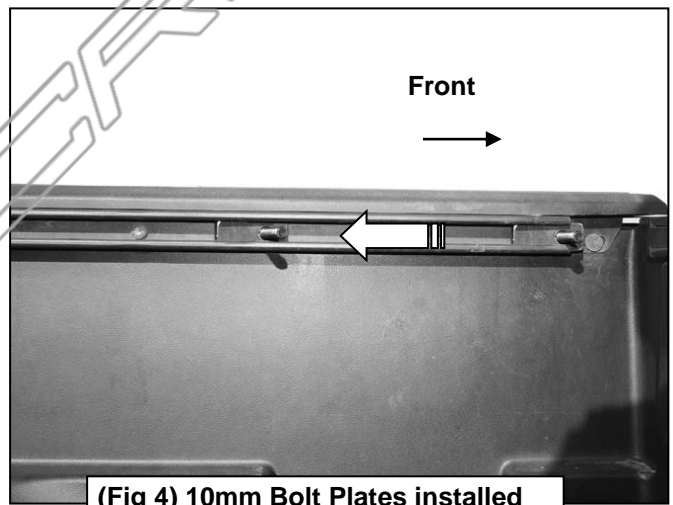

**(Fig 4) 10mm Bolt Plates installed**

- (3) 10mm Bolt Plates
- (3) 10mm Flat Washers
- (3) 10mm Lock Washers
- (3) 10mm Hex Nuts

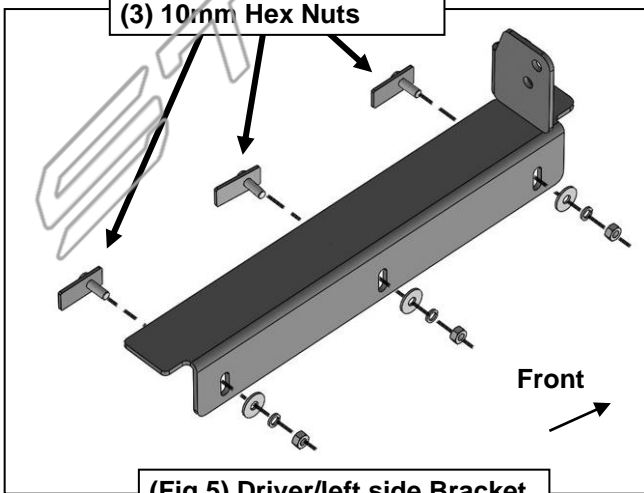

**(Fig 5) Driver/left side Bracket attached to bed rail**

- (2) 12mm Hex Bolts
- (4) 12mm Flat Washers
- (2) 12mm Lock Washers
- (2) 12mm Hex Nuts

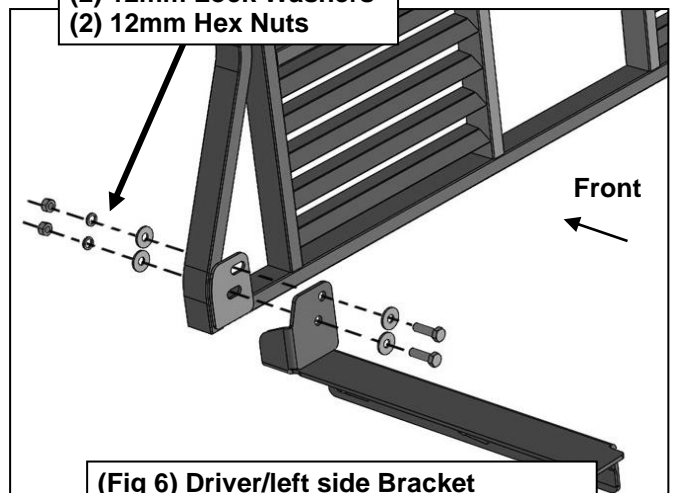

**(Fig 6) Driver/left side Bracket attached to Headache Rack assembly**