

# **INSTALLATION INSTRUCTIONS**

**1PAIR FORMED STYLE FRONT FENDERS W-LIGHT  
2018 JEEP WRANGLER JL**

**1PAIR FORMED STYLE FRONT FENDERS W-LIGHT  
2018 JEEP WRANGLER JL**

**PARTS LIST:**

1	Driver/Left Front Fender Assembly	22	8mm x 16mm x 1.6mm Flat Washers
1	Passenger/Right Front Fender Assembly	20	8mm Lock Washers
6	8mm Nut Plates	12	8-1.25mm Flange Nuts
14	8-1.25mm x 25mm Button Head Bolts	2	8-1.25mm Hex Nuts
2	8-1.25mm x 25mm Hex Bolts	1	4mm Wrench
4	8-1.25mm x 20mm Hex Bolts	1	5mm Wrench
		10	Wire Ties

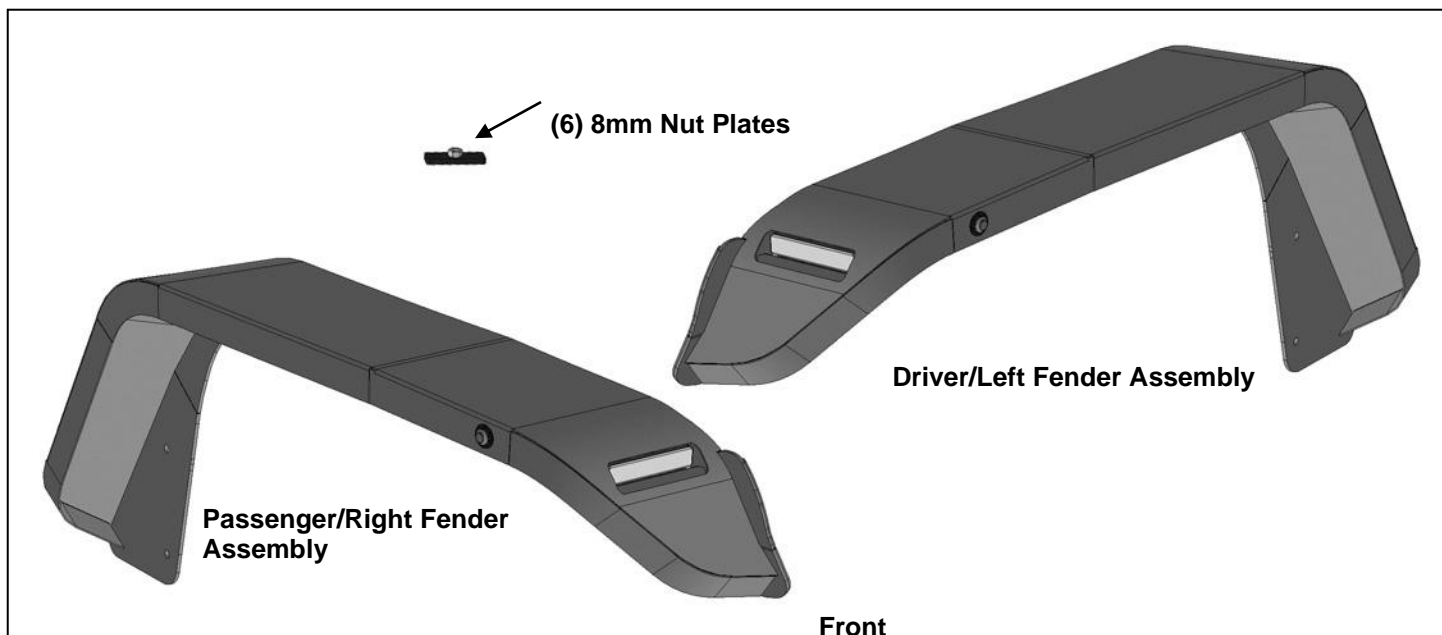

**PROCEDURE:**

**REMOVE CONTENTS FROM BOX. VERIFY ALL PARTS ARE PRESENT. READ INSTRUCTIONS CAREFULLY. DRILLING IS REQUIRED. CUTTING AND MODIFICATION IS REQUIRED TO REINSTALL THE PLASTIC FENDER LINER. ASSISTANCE IS RECOMMENDED.**

1. Start installation on the driver side of the vehicle. Release the plastic clips attaching the liner to the outer edge of the fender and the body, **(Figure 1)**. Locate and remove the bolts attaching the fender liner at the front and top of the liner and remove the fender liner, **(Figure 2)**.
2. Unplug the wiring harness leading from the body to the fender.
3. Next, release the plastic clips attaching the fender to the body. Firmly pull the fender straight outward from the body to pop the clips from the mounting holes, **(Figure 3)**. **OPTION:** On some clips, use a pair of needle nose pliers to reach the back of the clip and squeeze the tabs to release. Remove any clips left attached to the body panel and move the fender to a clean surface.
4. Select the driver/left Front Fender. Carefully place the Fender on the (2) upper mounting channels and front tab. Select (1) 8mm Nut Plate, Slide the Nut Plate into one of the channels on the underside of the fender, **(Figure 4)**. Line up the threaded hole in the Nut Plate with the slot in the channel. Attach the Fender with Nut Plate to the support channel with (1) 8mm x 20mm Hex bolt, (1) 8mm Lock Washer and (1) 8mm Flat Washer, **(Figure 5)**. Do not tighten at this time. Repeat this Step to attach the Fender to the remaining support channel and Nut Plate.
5. Select (1) 8mm Nut Plate, Slide the Nut Plate into the gap between the inner and outer body panel toward the rear of the Fender, **(Figure 6)**. Attach the Fender to the Nut Plate with (1) 8mm x 25mm Button Head Bolt, (1) 8mm Lock Washer and (1) 8mm Flat Washer. Leave hardware loose.
6. Next, attach the Fender to the mount on the front of the body with the included (1) 8mm x 25mm Hex Bolt, (2) 8mm Flat Washers, (1) 8mm Lock Washer and (1) 8mm Hex Nut, **(Figure 7)**. Do not tighten hardware at this time.

## 1PAIR FORMED STYLE FRONT FENDERS W-LIGHT 2018 JEEP WRANGLER JL

7. Line up the mounting holes in the fender with the holes in the body. Line up the fender with the body. Use a marker to trace the mounting holes in the fender onto the body panel. Use a 5/16" drill bit as necessary to drill or enlarge any mounting holes. Apply paint or sealant (not included) to unpainted surfaces to prevent rust. Attach the Fender to the body with the included (6) 8mm x 25mm Button Head Bolts, (6) 8mm Lock Washers, (6) 8mm Flat Washers and (6) 8mm Flange Nuts, **(Figures 8 & 9)**. Do not fully tighten hardware at this time.
8. Attach the plug on the wiring harness to the factory plug toward back of fender, **(Figure 10)**.  
**IMPORTANT:** Make sure wiring harness is fully protected from heat and that it cannot come in contact with sharp edges along body and fender. Secure harness to vehicle with included plastic wire ties.
9. Determine if vehicle is equipped with standard light package or option LED light package.  
**Models with standard light package:**
  - a. Plug wiring harness into main harness and skip to **Step 10**.**Models with LED option light package:**
  - a. Unplug wires leading into and out of the resister, **(Figures 11A & 11B)**. Resister is not required for LED light package.
  - b. Seal open plugs on wiring harness with electrical tape or sealant (not included).
10. With the fender in place, determine if plastic fender liner will be reinstalled. **NOTE:** Aluminum fender liners, (available separately), are highly recommended.
  - a. Slide plastic fender liner into position.
  - b. Trim the outer edge from the liner to match the Fender. **NOTE:** Actual amount to remove from liner to be determined by installer. Leave as many mounting points on the plastic liner as possible.
  - c. Reinstall modified liner over wiring harness.
11. Adjust the position of the Fender and fully tighten all hardware.
12. Repeat **Steps 1—11** for passenger/right side Tube Fender installation.
13. Do periodic inspections to the installation to make sure that all hardware is secure and tight.

**To protect your investment,** Do not use any type of polish or wax that may contain abrasives that could damage the finish. Mild soap may be used to clean the Tube Style Fenders.

### Driver Side Installation Pictured



**(Fig 1)** Release clips attaching fender liner to outer fender



**(Fig 2)** Remove hardware attaching fender liner to front, top and back of fender (passenger/right side pictured)

1PAIR FORMED STYLE FRONT FENDERS W-LIGHT  
2018 JEEP WRANGLER JL

Driver Side Installation Pictured



(Fig 3) Firmly pull fender straight out from vehicle

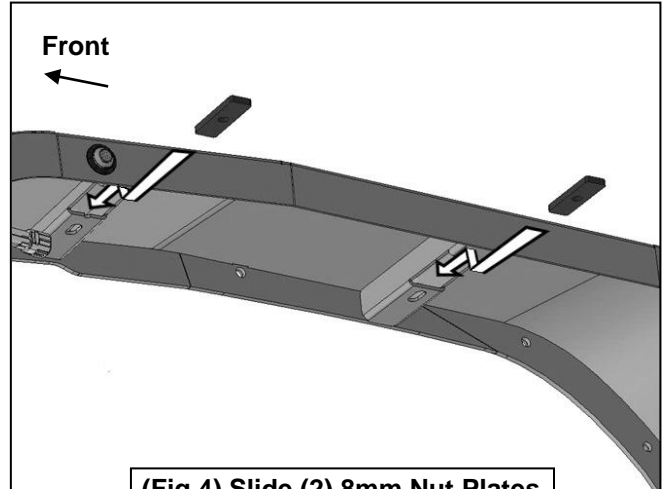

(Fig 4) Slide (2) 8mm Nut Plates into channels under Fender

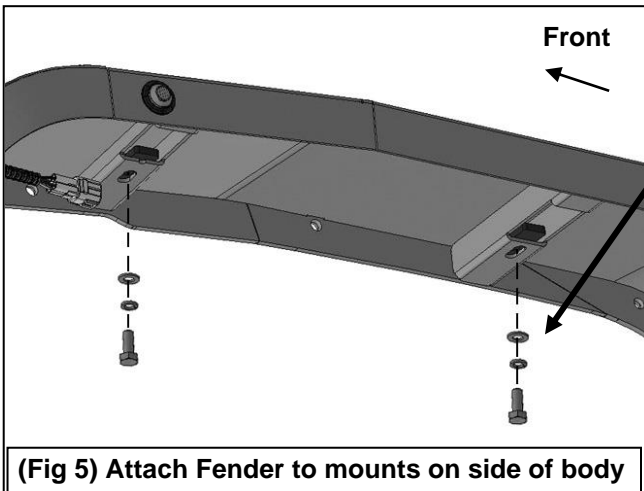

(Fig 5) Attach Fender to mounts on side of body

- (2) 8mm x 20mm Hex Bolts
- (2) 8mm Lock Washers
- (2) 8mm Flat Washers
- (2) 8mm Nut Plates

- 8mm x 25mm Button Head Bolt
- 8mm Lock Washer
- 8mm Flat Washer
- 8mm Nut Plate

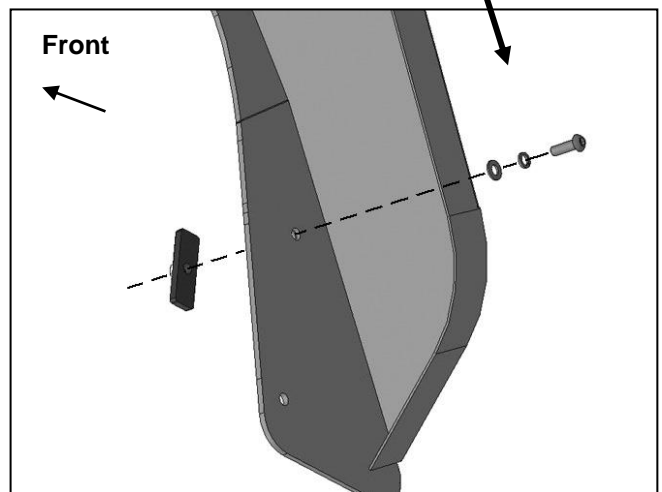

(Fig 6) Slide 8mm Nut Plate behind mounting hole in body panel. Attach Fender to Nut Plate

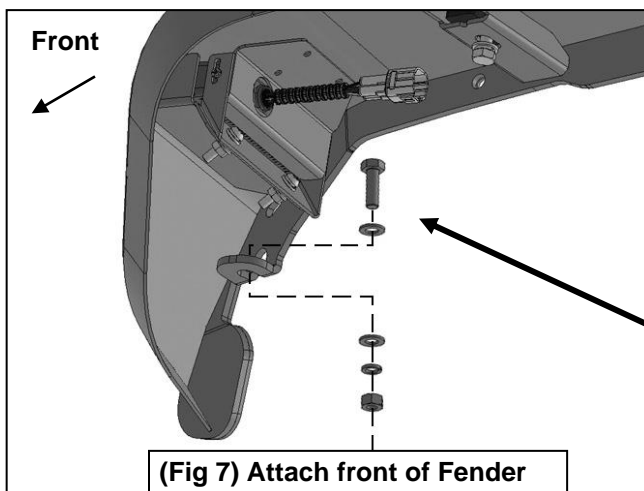

(Fig 7) Attach front of Fender to mounting tab on body

- 8mm x 25mm Hex Bolt
- (2) 8mm Flat Washers
- 8mm Lock Washer
- 8mm Hex Nut

1PAIR FORMED STYLE FRONT FENDERS W-LIGHT  
2018 JEEP WRANGLER JL

Driver Side Installation Pictured

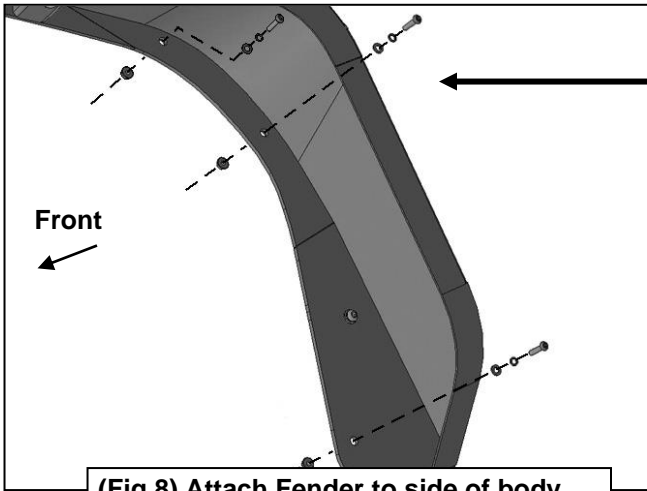

(Fig 8) Attach Fender to side of body

- 8mm x 25mm Button Head Bolts
- 8mm Lock Washers
- 8mm Flat Washers
- 8mm Flange Nuts

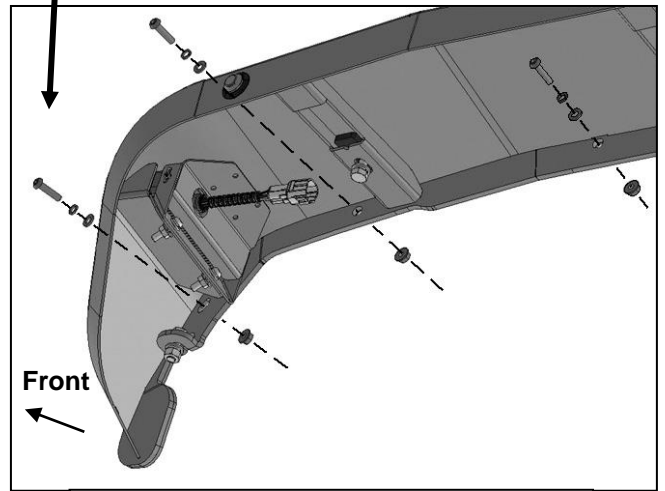

(Fig 9) Attach Fender to side of body

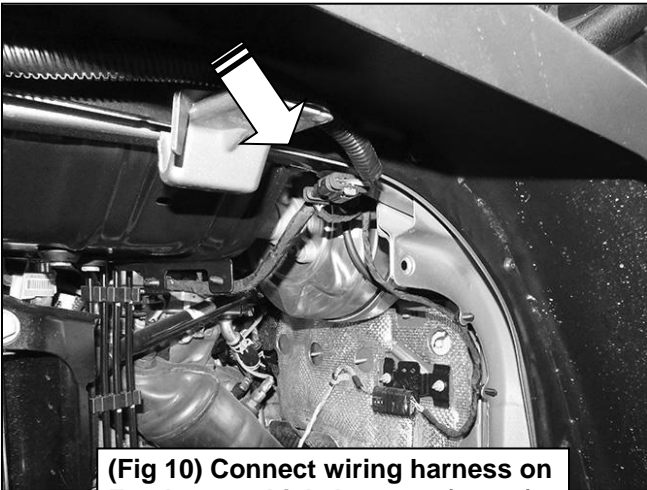

(Fig 10) Connect wiring harness on Fender to vehicle harness (arrow).

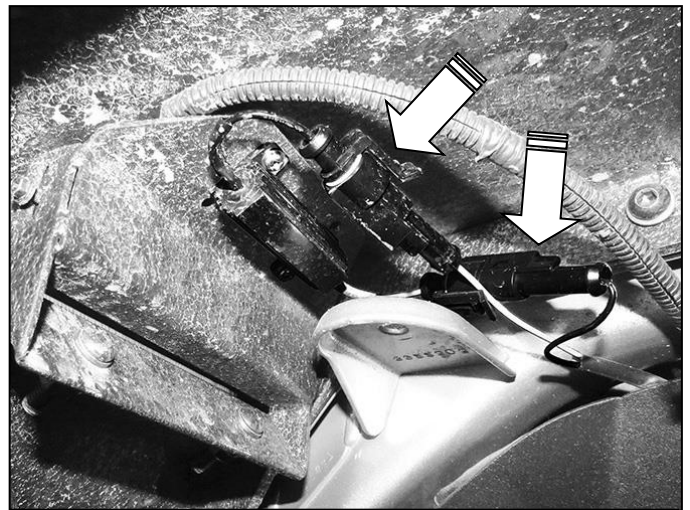

(Fig 11A) Models with factory LED lighting package only, unplug both connectors (arrows) leading to and from the resistor

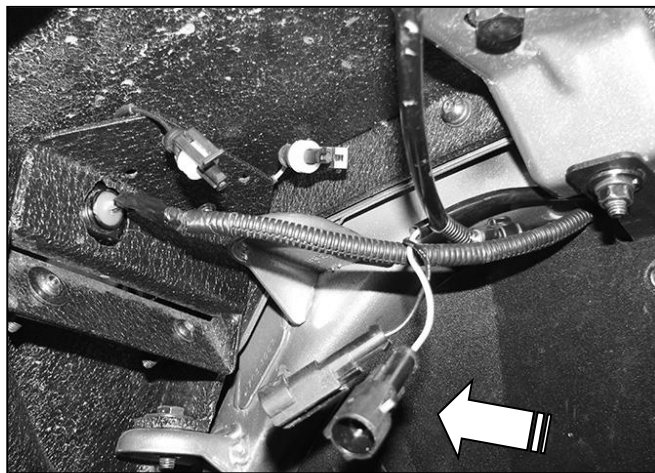

(Fig 11B) Seal open connectors on harness with waterproof tape or sealant (not included).