

**HD REPLACEMENT REAR BUMPER  
2015-20 FORD F150**

**PARTS LIST:**

1	HD Replacement Rear Bumper Assembly	2	10mm x 35mm Double Bolt Plates
1	Driver/left Mounting Bracket	4	10mm x 30mm x 2.5mm Flat Washers
1	Passenger/right Mounting Bracket	4	10mm Nylon Lock Nuts
4	Sensor Hole Plugs	4	10mm Plastic Retainers
4	Retaining Ring	8	4mm x 10mm Button Head Bolts
4	Foam Spacer Washer 20mm x 10mm	1	2.5mm Wrench
4	Sealing Washer	2	Plastic Plugs for license plate mount
1	Sensor Cover Kit	1	License Plate Light

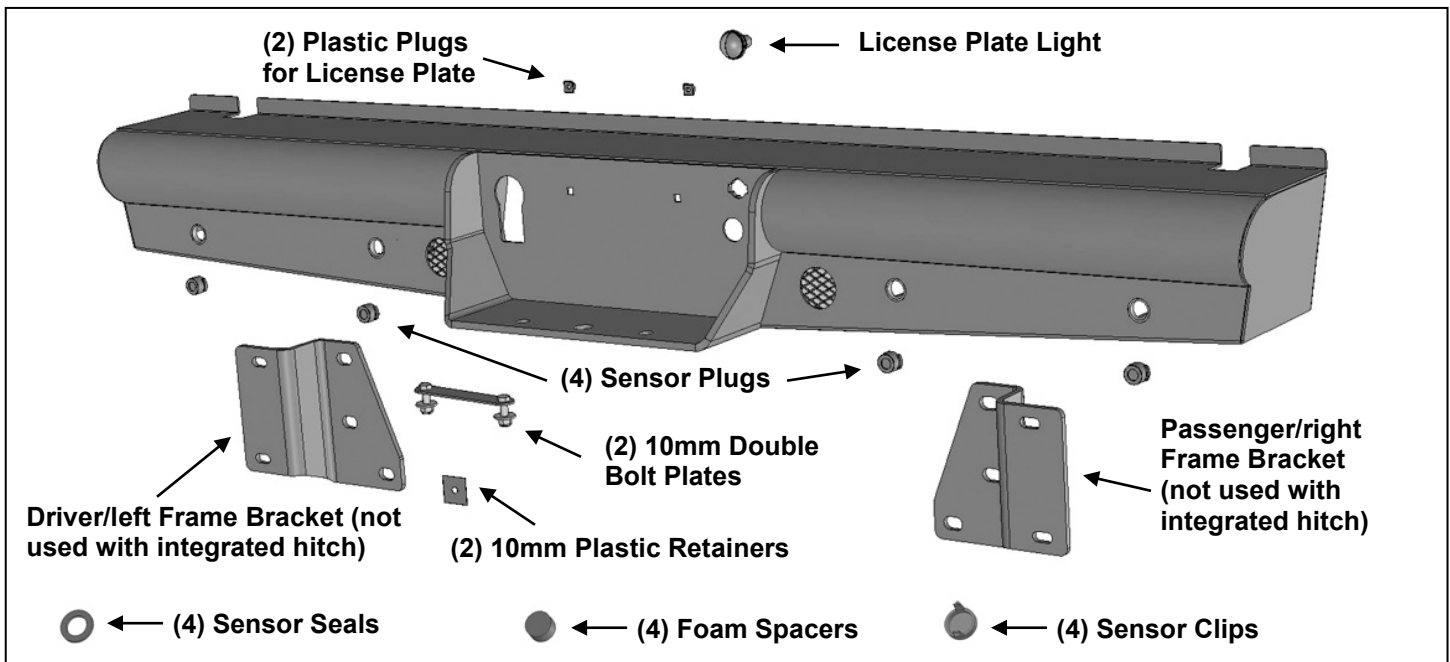

**PROCEDURE:**

**REMOVE CONTENTS FROM BOX. VERIFY ALL PARTS ARE PRESENT. READ INSTRUCTIONS CAREFULLY BEFORE STARTING INSTALLATION. BUMPER IS HEAVY, ASSISTANCE IS RECOMMENDED TO AVOID POSSIBLE INJURY OR DAMAGE TO THE VEHICLE.**

**IMPORTANT: OEM BUMPER REINFORCEMENT USED WITH “STANDARD” TOW PACKAGE WITHOUT RECEIVER HITCH CANNOT BE REINSTALLED. OE INTEGRATED “HD” HITCH, “MAX DUTY” HITCH AND MOST AFTERMARKET RECEIVER HITCHES REQUIRED FOR TOWING.**

1. Remove the license plate from the bumper, (**Figure 1**). Unplug the wiring harness leading to the bumper and move harness away from bumper, (**Figure 2**). **NOTE:** Steelcraft Bumper is designed to be compatible with larger 7-wire universal trailer harness plug only.
2. Place blocks or jack stands under the bumper to support it during mounting bolt removal. Once the bumper has been safely supported, remove the factory hardware attaching the bumper to the end of the frame and remove the bumper assembly, (**Figures 3A, 3B & 4**). Models equipped with “Max Duty” receiver hitch, (**Figure 5**), leave hitch in place on frame. **WARNING!** Assistance is required to hold the bumper in place during hardware removal to prevent bumper from falling.
3. Remove sensors, (if equipped), from bumper. Release the clips securing the trailer plug and remove the plug, (**Figure 1**). Remove the wiring harness from the bumper, (**Figure 2**). Next, remove the spare tire plug lock if equipped.
4. Reinstall the spare tire hole plug lock and trailer plug into the HD Bumper. **NOTE:** Use a flat blade screwdriver to carefully pry out the metal clips on the plug to grab the edge of the opening.
5. Determine if the vehicle is equipped with sensors. **NOTE:** Depending on tow package, (**Figures 5 & 14**), it may be necessary or easier to install sensors, (if equipped), and harness before installing the Bumper.

**Models without bumper sensors:**

- a. Select the included (4) Rubber Plugs, **(Figure 6)**.
- b. From behind bumper, push plugs into sensor mounting sleeves, **(Figure 6)**. Screws have been provided to lock the plugs into the sleeves. Use is optional.

**Models with bumper mounted sensors:**

- a. Select (1) sensor. Test fit sensor in mounting sleeve. It may be necessary to cut or grind off the tabs on the sides of the sensor to fit into the sleeve.
  - b. Remove the seal from the end of the sensor. Slide the included larger Sensor Seal over front of the sensor, **(Figure 7)**.
  - c. Insert the sensor with Seal into sensor mount, **(Figure 8)**.
  - d. Place thick Foam Spacer over end of the sensor. Push Sensor Retaining Clip into sensor mount and lock into mounting holes, **(Figure 8)**.
  - e. Repeat previous Steps to install remaining sensors.
  - f. Install wiring harness for sensors and plug harness into sensors and/or trailer plug.
  - g. **Optional:** Secure each sensor to the socket with (2) 4mm x 10mm Button Head Screws, **(Figure 11)**. **IMPORTANT:** Sensors fit snug in sockets. The 4mm Screws are used to apply slight pressure to lock the sensors in place. Tighten both screws evenly until they touch the sensor body only. Do not overtighten screws or damage to sensors will result.
6. Insert the included License Plate Light into the hole in the Bumper, **(Figure 9)**. Attach the wiring harness to the sensors, lights and trailer plug.
7. Use a small flat blade screwdriver to pry the star washers off of the bolt plates used to attach the factory bumper to the frame, **(Figure 10)**. **NOTE:** “HD” tow package models use a triple bolt plate, “Standard” and “Max Duty” equipped models use a double bolt plate, **(Figure 11)**.
8. **Determine towing package supplied with vehicle:**
- Models with “standard tow package” without HD receiver below bumper and models with “Max Duty” frame mounted receiver hitch below bumper, (Figure 5).**
- a. Reuse the factory bolt plate and hardware to attach the passenger/right Mounting Bracket to the end of the frame, **(Figure 8)**. Repeat to attach the driver/left Mounting Bracket to the frame.
  - b. Select (1) 10mm Double Bolt Plate and (2) 10mm Plastic Retainers. Insert the Double Bolt Plate into and through the back of the mounting tab on the passenger/right side of the Bumper, **(Figure 12)**. Thread each Retainer down the Bolt Plate to help hold it in position in the Bumper. Repeat to install the Double Bolt Plate in the driver/left side of the Bumper.
  - c. With assistance, hold the Bumper assembly up to the Brackets. Temporarily support the weight of the Bumper. **WARNING:** To avoid possible injury or damage to the vehicle, do not proceed until the bumper is fully and safely supported.
  - d. Attach the passenger/right side of the Bumper, (10mm Bolt Plate), to the Bracket with (2) 10mm Flat Washers and (2) 10mm Nylon Lock Nuts, **(Figure 13)**. Snug but do not fully tighten hardware at this time. Repeat to attach the driver/left side of the Bumper to the Bracket.
  - e. Skip to **Step 9**.
- Models with “HD” tow package with integrated receiver hitch in bumper and brackets.**
- a. Remove integrated receiver hitch and bracket assembly from back of bumper.
  - b. Reuse factory hardware to reinstall receiver/bumper bracket assembly to mounts on ends of frame, **(Figure 14)**. Snug but do not fully tighten hardware at this time.
  - c. Select (1) 10mm Double Bolt Plate and (2) 10mm Plastic Retainers. Insert the Double Bolt Plate into and through the back of the mounting tab on the passenger/right side of the Bumper, **(Figure 15)**. Thread each Retainer down the Bolt Plate to help hold it in position in the Bumper. Repeat to install the Double Bolt Plate in the driver/left side of the Bumper.
  - d. With assistance, attach the passenger/right side of the Bumper, (10mm Bolt Plate), to the receiver/bumper bracket assembly with (2) 10mm Flat Washers and (2) 10mm Nylon Lock Nuts, **(Figure 15)**. Temporarily support the weight of the Bumper. Repeat to attach the driver/left side of the Bumper assembly. **WARNING:** To avoid possible injury or damage to the vehicle, do not proceed until the bumper is fully and safely supported. Snug but do not fully tighten hardware at this time. Continue to **Step 9**.

**HD REPLACEMENT REAR BUMPER  
2015-20 FORD F150**

9. Level and adjust the bumper and slowly lower the tailgate and check for clearance. Adjust the bumper as required and fully tighten all hardware to 65-70ft-lbs.
10. Do periodic inspections to the installation to make sure that all hardware is secure and tight.
11. Use the included (2) push-in plugs to attach the license plate to the Bumper, **(Figure 9)**.
12. Plug in the wiring harness on the bumper to the main harness on the vehicle.
13. Do periodic inspections to the installation to make sure that all hardware is secure and tight.

**To protect your investment**, wax this product after installing. Regular waxing is recommended to add a protective layer over the finish. Do not use any type of polish or wax that may contain abrasives that could damage the finish. Mild soap may be used to clean the Bumper assembly.

**Passenger Side Installation Pictured**



**(Fig 1) Unplug and remove 7-wire trailer plug**



**(Fig 2) Unplug license plate lights**

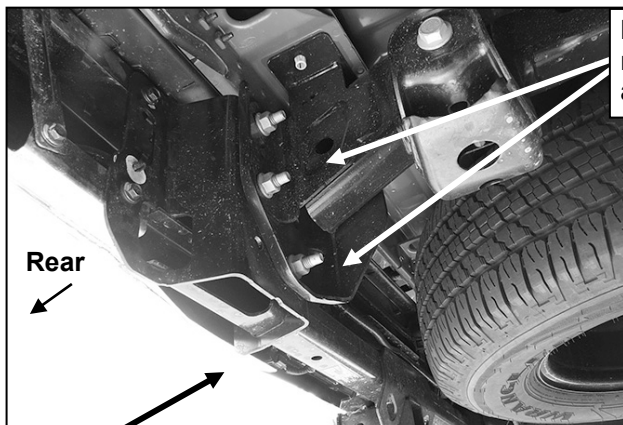

**(Fig 3A) Note bumper with integrated receiver hitch**

**Remove the factory hex nuts attaching bumper assembly to frame**

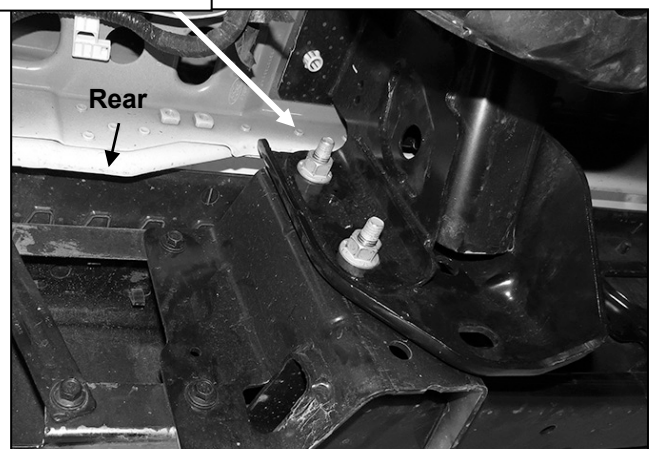

**(Fig 3B) Remove the factory hex nuts attaching bumper assembly to frame. STD tow package model pictured (no receiver hitch)**

**WARNING!** Do not crawl under bumper unless the bumper is properly supported on blocks or stands or the bumper may fall.

Passenger Side Installation Pictured

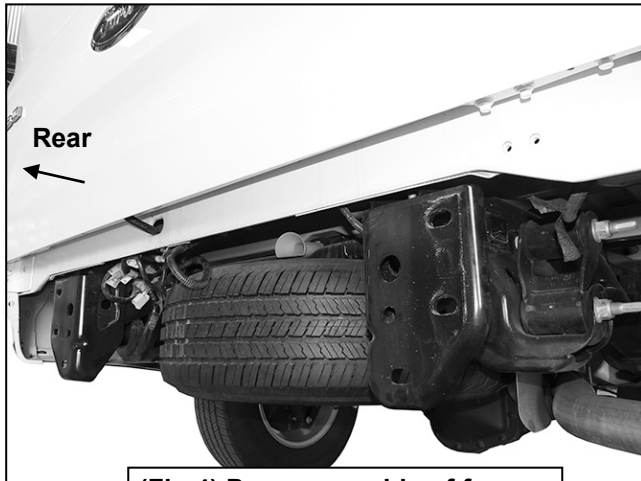

(Fig 4) Passenger side of frame

**WARNING!** Do not remove bumper bolts unless the bumper is properly supported on blocks or stands or the bumper may fall.

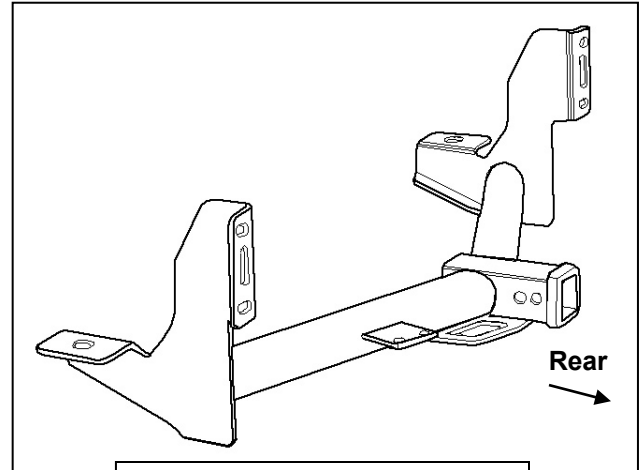

(Fig 5) Example of "Max Duty" OE style receiver hitch

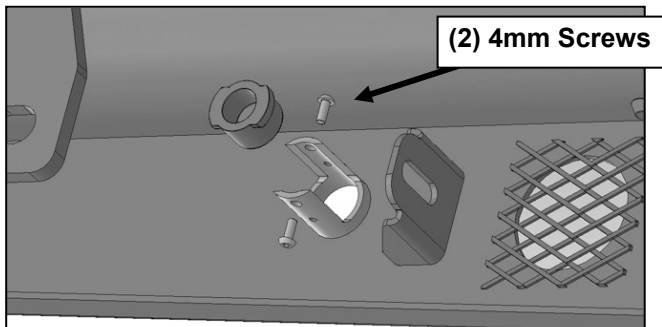

(Fig 6) Push sensor plug into mounting sleeve. Use of 4mm Screws is optional

**NOTE:** Sensor plugs fit snug in sockets. Use of the 4mm Screws is optional. 4mm Screws can also be used to apply slight pressure to lock the sensors in place or to aim the sensor. Tighten both screws evenly until they touch the sensor body only. Do not overtighten screws or damage to sensors will result.

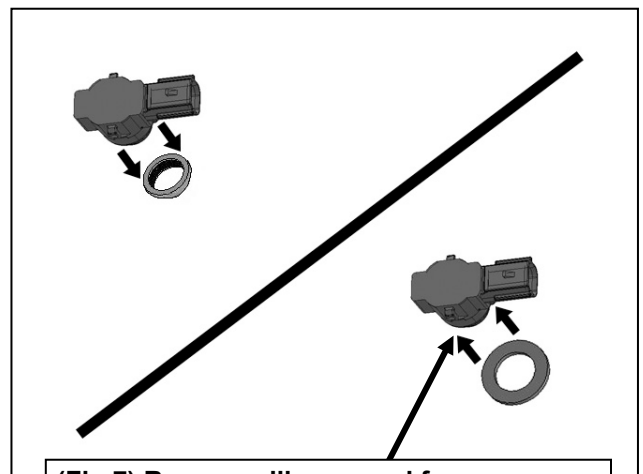

(Fig 7) Remove silicone seal from sensor. Slide large Seal over end of sensor (arrow)

Passenger Side Installation Pictured

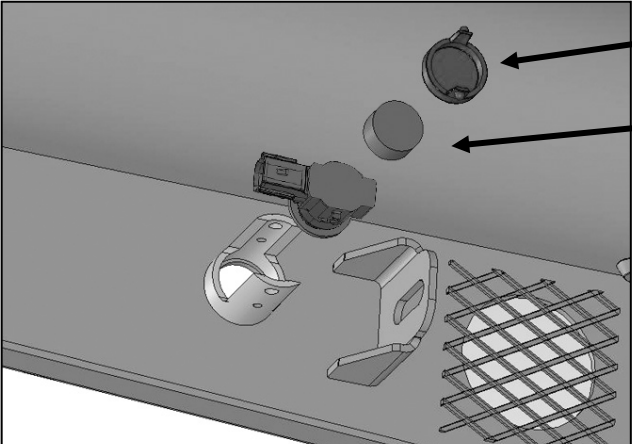

Sensor Clip

Foam Spacer

Insert supplied License Plate Light and (2) Plugs for license plate

Insert OE hitch plug

(Fig 8) Slide sensor into sleeve, insert Foam Spacer and Clip to lock sensor in sleeve

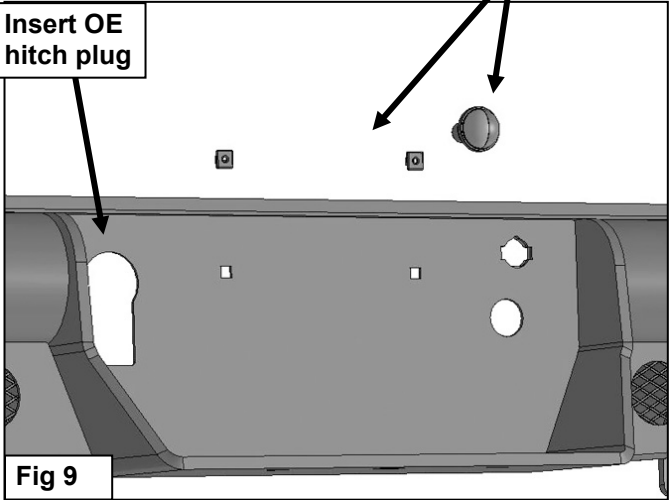
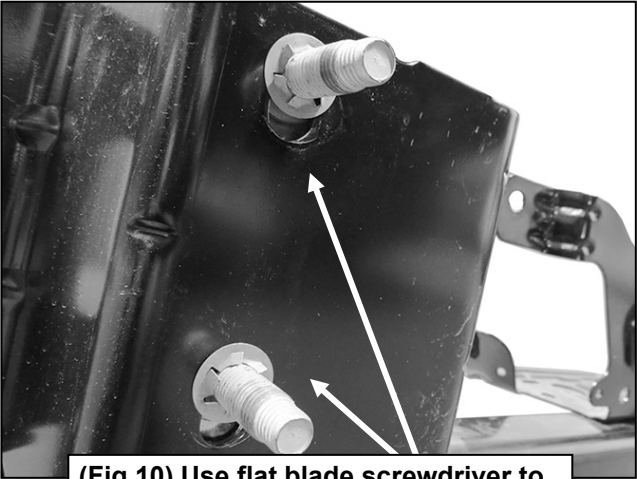
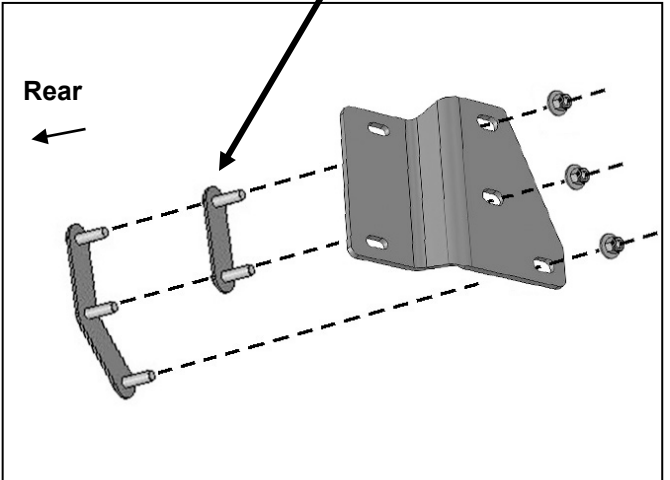

Fig 9



(Fig 10) Use flat blade screwdriver to pry off lock washers from bolt plates

Factory double bolt late used on model w/o receiver hitch and "max tow" frame mounted receiver hitch. Factory triple bolt plate used with "HD tow" package with integrated receiver hitch



(Fig 11) Reuse either factory bolt plate to attach passenger/right Mounting Bracket to end of frame

Passenger Side Installation Pictured

**WARNING!** Do not crawl under bumper unless the bumper is properly supported on blocks or stands or the bumper may fall.

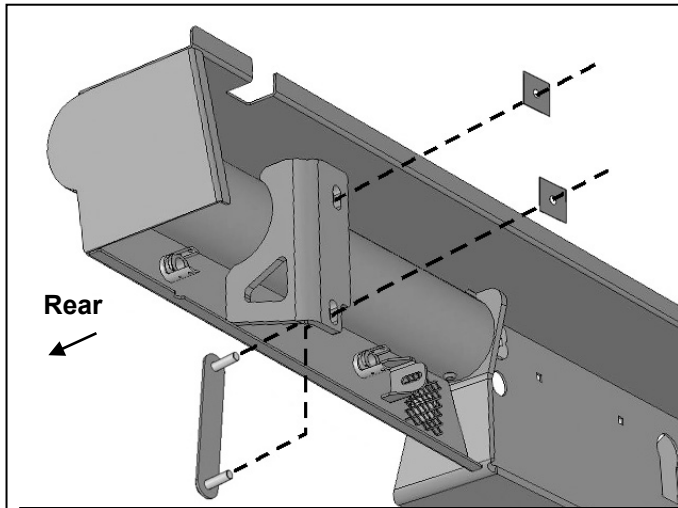

(Fig 12) Insert 10mm Double Bolt Plate into and through back of mounting tab on back of Bumper

(2) 10mm Flat Washers  
(2) 10mm Nylon Lock Nuts

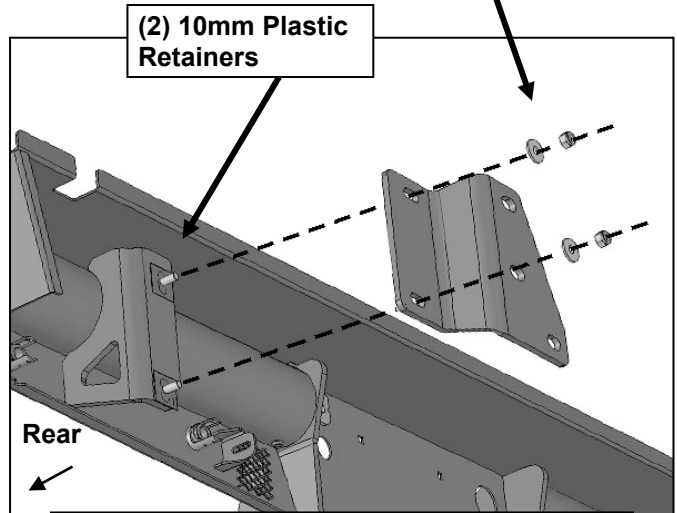

(Fig 13) Use 10mm Plastic Retainers to hold Double Bolt Plate in position in Bumper

(2) 10mm Flat Washers  
(2) 10mm Nylon Lock Nuts

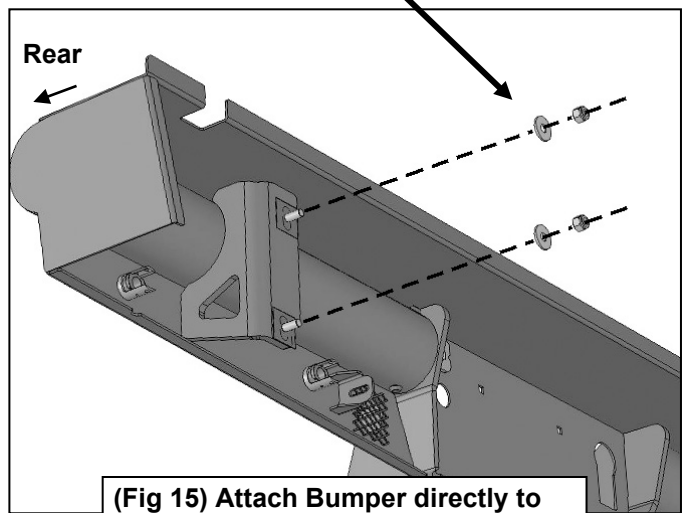

(Fig 15) Attach Bumper directly to integrated hitch bracket (see Fig 12)

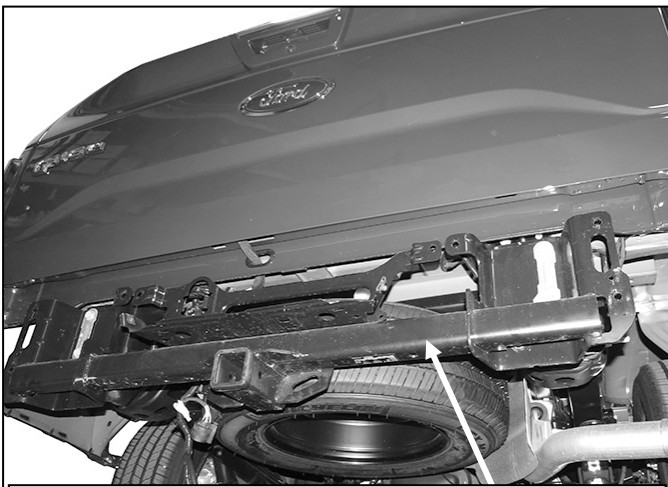

(Fig 14) Reinstall integrated receiver hitch/bracket assembly on models with "HD Towing" package