

**ELEVATION FRONT BUMPER
2015-19 GMC SIERRA 25-3500**

PARTS LIST:

1	Elevation Front bumper	2	Plastic Plugs for License Plate
2	Frame Mounting Brackets (fit left or right)	2	12mm Bolt Plates
2	Support Brackets (fit left or right)	6	12-1.75mm x 160mm Hex Bolts
4	Sensor Retaining Clips	2	12-1.75mm x 50mm Hex Bolts
4	20mm x 2mm Foam Spacers	18	12mm x 37mm OD x 3mm Flat Washers
4	Sealing Washers	10	12mm Lock Washers
3	Wire Harness Extensions	10	12mm Hex Nuts
4	Sensor Plugs	8	4mm x 10mm Button Head Screws
1	Sensor Cover Kit	1	2.5mm Wrench

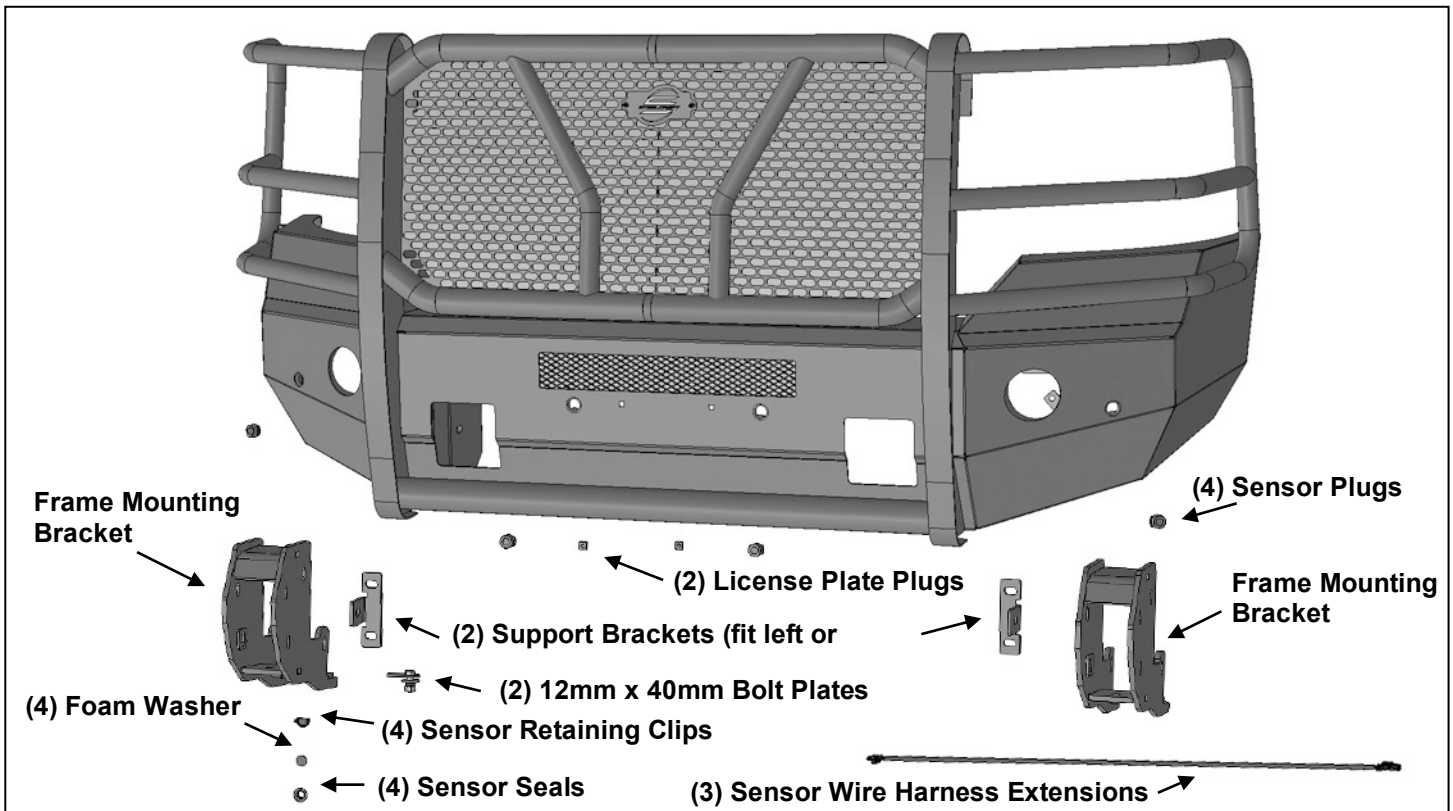

PROCEDURE:

REMOVE CONTENTS FROM BOX. VERIFY ALL PARTS ARE PRESENT. READ INSTRUCTIONS CAREFULLY BEFORE STARTING INSTALLATION. BUMPER IS HEAVY, ASSISTANCE IS HIGHLY RECOMMENDED TO AVOID POSSIBLE INJURY OR DAMAGE TO THE VEHICLE.

1. Remove the license plate and bracket. On models with factory fog lights and/or bumper sensors, unplug the wiring harness leading to the front bumper and move it out of the way, **(Figure 1)**.
2. Remove the bumper supports running from the outside of the frame to the outer ends of the bumper.
3. Open the hood and remove the plastic cover from the top of the radiator, **(Figure 2)**. Temporarily remove the plastic grille, **(Figure 3)**.
4. Place blocks or jack stands under the front bumper to support it during mounting bolt removal. Once the bumper has been safely supported, from above the bumper, remove the (2) factory bumper bolts from each side, **(Figure 4)**. **WARNING!** Assistance is required to hold the bumper in place during bolt removal to prevent the bumper from falling. Carefully slide the bumper off of the end of the frame.
5. Remove the factory bumper brackets and tow hooks from the end of frame, **(Figure 5)**.
6. Select (1) Frame Mounting Bracket. Attach the Bracket to the driver/left end of the frame with the included (1) 12mm x 160mm Hex Bolt, (2) 12mm Flat Washers, (1) 12mm Lock Washer and (1) 12mm Hex Nut, **(Figures 6 & 9)**. Next, attach the bottom of the Frame Bracket to the bottom of the frame with (1) 12mm Bolt Plate, (1) 12mm Flat Washer, (1) 12mm Lock Washer and (1) 12mm Hex Nut, **(Figures**

**ELEVATION FRONT BUMPER
2015-19 GMC SIERRA 25-3500**

- 6 & 9). NOTE:** Insert the Bolt Plate into the end of the frame and down through the bottom and through the Bracket. Do not fully tighten hardware at this time.
7. Next, select (1) Support Bracket, **(Figure 7)**. Reuse (2) factory bumper bracket bolts to attach the Support Bracket to the mounting plate on the end of the frame, **(Figures 7 & 8)**. Do not attach the Support Bracket to the side of the Frame Bracket at this time, (See **Step 12, Fig. 13A**). Do not fully tighten hardware at this time.
 8. Repeat **Steps 6 & 7** to install the passenger side Frame and Support Brackets, **(Figure 9)**.
 9. Carefully unwrap the Bumper assembly. Determine if accessory light, (not included), will be installed at this time. **IMPORTANT:** It may be easier to install lights and sensors before installing Bumper.
Inner center LED bar style light installation (light not included).
 - a. Attach the light to the mounting tabs on the back of the Bumper, **(Figure 10)**.
 10. Determine if the vehicle is equipped with bumper mounted parking sensors.
Models without bumper sensors:
 - a. Select the included (4) Rubber Plugs.
 - b. From behind bumper, push plugs into sensor mounting holes, **(Figure 10)**. **NOTE:** 4mm screws have been included to help lock plugs in the sleeves-use is optional.**Models with bumper mounted sensors:**
 - a. Remove factory wiring harness and sensors from the bumper.
 - b. Select (1) sensor. Remove the silicone seal from the end of the sensor. Slide the included larger Sensor Seal over the front of the sensor, **(Figure 11)**.
 - c. Insert sensor with Seal into sensor mount on back of Bumper, **(Figure 12)**.
 - d. Place Foam Washer over end of sensor. Push Sensor Retaining Clip into sensor mount and lock into mounting holes, **(Figure 12)**.
 - e. Repeat previous **Steps** to install remaining sensors.
 - f. Install factory wiring harness for sensors and plug harness into sensors. **NOTE:** It may be necessary to remove or unwrap some of the outer loom to extend the harness to reach all sensors. Use the included Wiring Harness Extensions to extend the factory harness as necessary.
 - g. **Optional:** Secure each sensor to the socket with the included (2) 4mm x 10mm Button Head Screws. **IMPORTANT:** Sensors fit snug in sockets. The 4mm Screws are used to apply slight pressure to lock the sensors in place or aim sensors. Tighten both screws evenly until they touch the sensor body only. Do not overtighten screws or damage to sensors will result.
 11. With assistance, position the Bumper Assembly up to and over the Brackets. Temporarily support the weight of the Bumper. **WARNING:** To avoid possible injury or damage to the vehicle, do not proceed until the Bumper is fully and safely supported.
 12. Line up the (3) holes in the driver side mounting plate on the back of the Bumper with the (3) slots in the Frame Bracket. Attach the Bumper to the top inner mounting hole in the Bracket with (1) 12mm x 160mm Hex Bolt, (2) 12mm Flat Washers, (1) 12mm Lock Washer and (1) 12mm Hex Nut, **(Figures 13A & 15)**. **NOTE:** Top Bolt will also attach Support Bracket to inside of Frame Bracket.
 13. Next, from in front of the Bumper, insert (1) 12mm x 50mm Hex Bolt, (2) 12mm Flat Washers, ((1) 12mm Lock Washer and (1) 12mm Hex Nut through the tow hook opening and out the slot in the outside of the Bracket, **(Figures 13A & 13B)**.
 14. Repeat **Steps 12 & 13** to attach the passenger side of the Bumper to the Frame Bracket.
 15. Select (1) factory tow hook if equipped. Insert the tow hook into the opening in the driver/left side Frame Bracket, **(Figure 14)**. Reuse the short factory tow hook hex bolt to attach the tow hook to the bottom plate on the Bracket. Insert (1) 12mm x 160mm Hex Bolt, (2) 12mm Flat Washers, (1) 12mm Lock Washer and (1) 12mm Hex Nut, through the Bumper Bracket and tow hook, **(Figure 15)**. Leave tow hook hardware loose at this time. Repeat this **Step** to install the passenger/right tow hook.
 16. Level and adjust the Bumper and fully tighten all hardware to 65-70ft-lbs.
 17. **Models with fog lights:**
 - a. Slide the driver/left side light into place through the opening in the bumper, **(Figure 16)**. Carefully push the attaching posts into the tabs on the bumper, **(Figure 17)**. Reattach the factory wiring harness to the light.
 - b. Repeat this **Step** to install passenger/right side light.

**ELEVATION FRONT BUMPER
2015-19 GMC SIERRA 25-3500**

18. Use the included (2) push-in Plastic Nuts to attach the front license plate, (if required), to the (2) holes in the front Bumper, **(Figure 18)**.
19. Do periodic inspections to the installation to make sure that all hardware is secure and tight.

To protect your investment, Do not use any type of polish or wax that may contain abrasives that could damage the finish. Mild soap may be used to clean the Front Bumper assembly.

Driver/left Side Installation Pictured

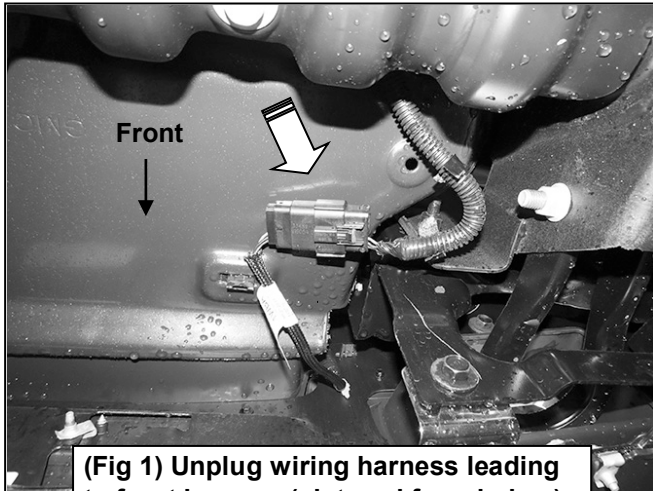

(Fig 1) Unplug wiring harness leading to front bumper (pictured from below)

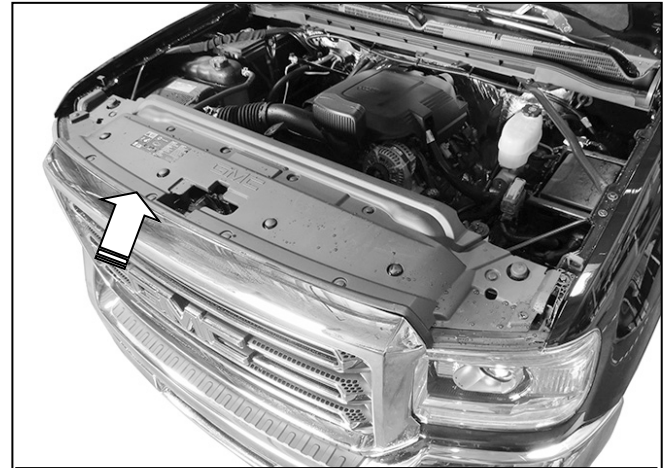

(Fig 2) Remove plastic cover from top of radiator

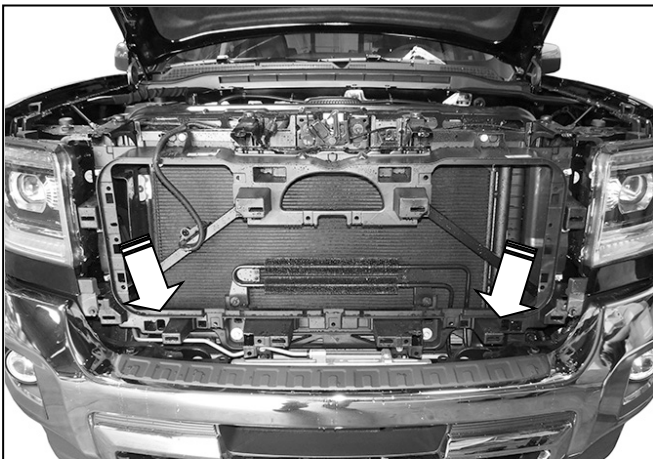

(Fig 3) Remove grille to access bumper bolts (Fig 4)

WARNING! Do not remove bumper bolts unless the bumper is properly supported on blocks or stands or the bumper may fall.

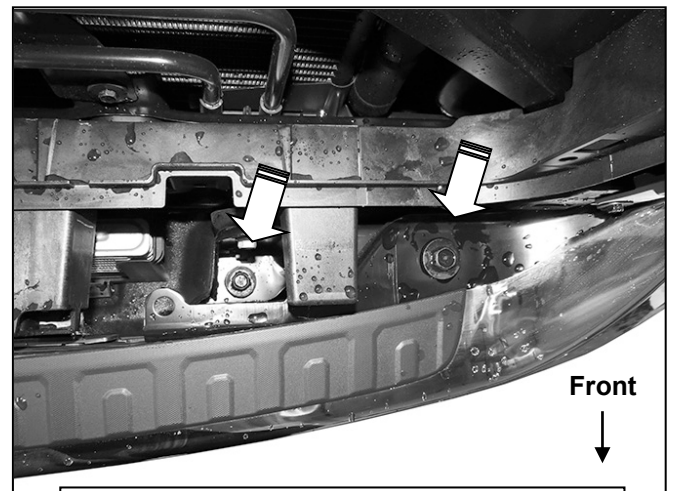

(Fig 4) Remove outer bumper supports attached to frame and ends of the bumper. Remove bumper bolts (arrows) to remove bumper (driver side pictured from above).

Driver Side Installation Pictured

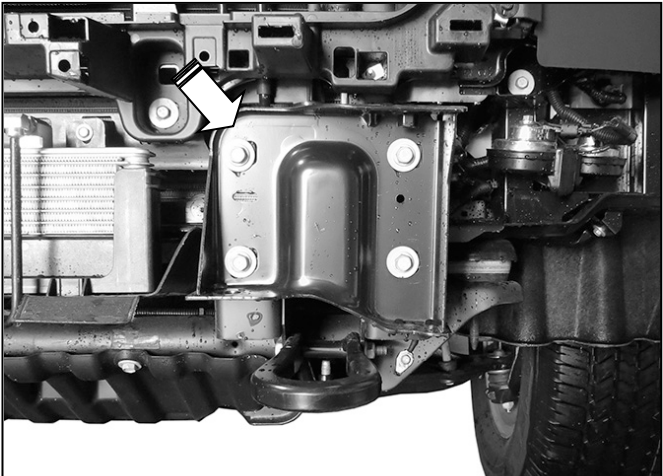

(Fig 5) Remove bumper brackets and tow hooks

WARNING! Do not crawl under bumper unless the bumper is properly supported on blocks or stands or the bumper may fall.

- 12mm Bolt Plate
- 12mm Flat Washer
- 12mm Lock Washer
- 12mm Hex Nut

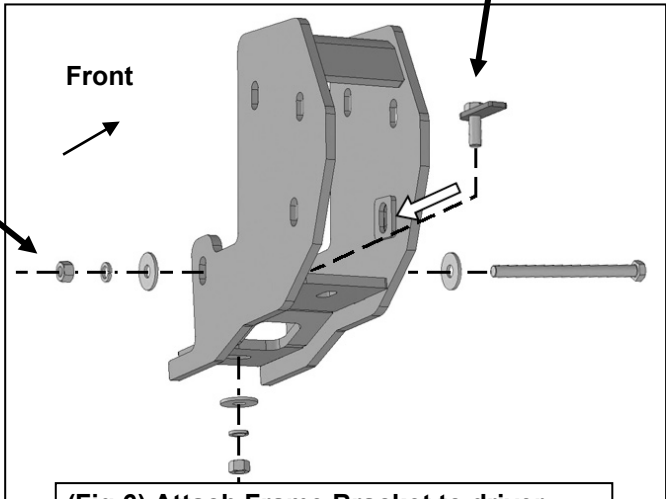

(Fig 6) Attach Frame Bracket to driver side of frame. Insert 12mm Bolt Plate down through hole in bottom of the frame

- 12mm x 160mm Hex Bolt
- (2) 12mm Flat Washers
- 12mm Lock Washer
- 12mm Hex Nut

Reuse factory bumper bracket bolts

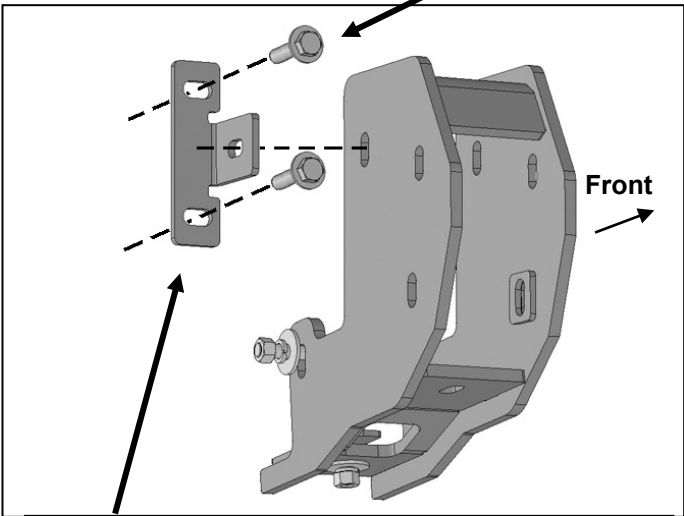

(Fig 7) Reuse factory bumper bolts to attach Support Bracket to bumper/frame mounting plate

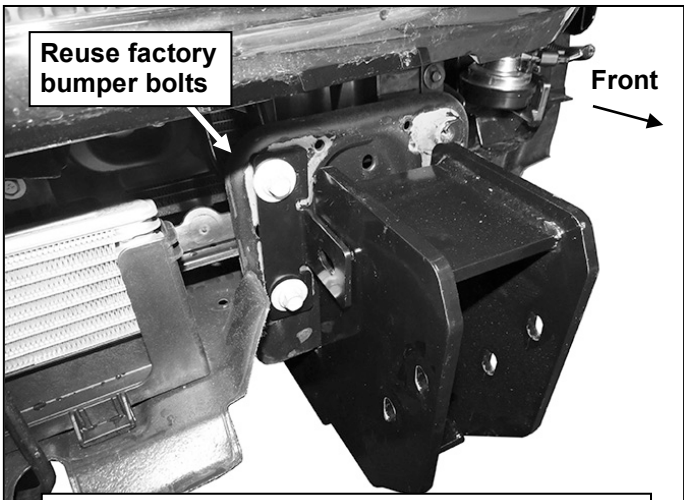

(Fig 8) Mounting Bracket and Support Bracket

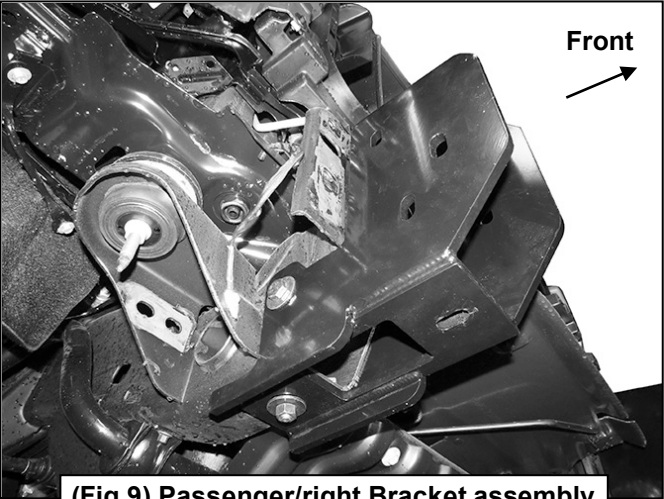

(Fig 9) Passenger/right Bracket assembly

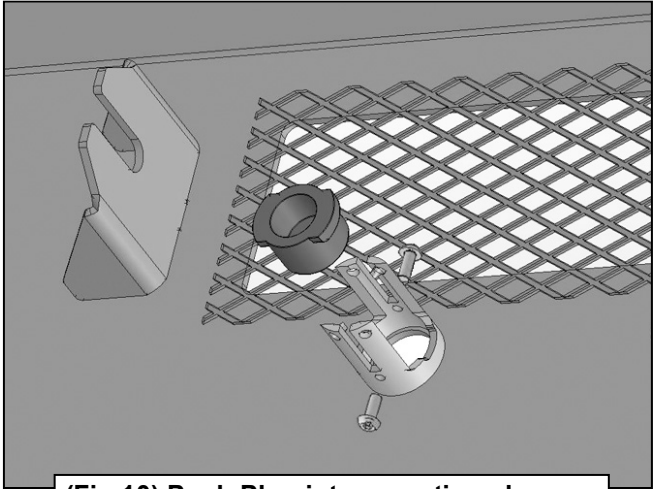

(Fig 10) Push Plug into mounting sleeve.
Use 4mm Screws to hold Plug in place.

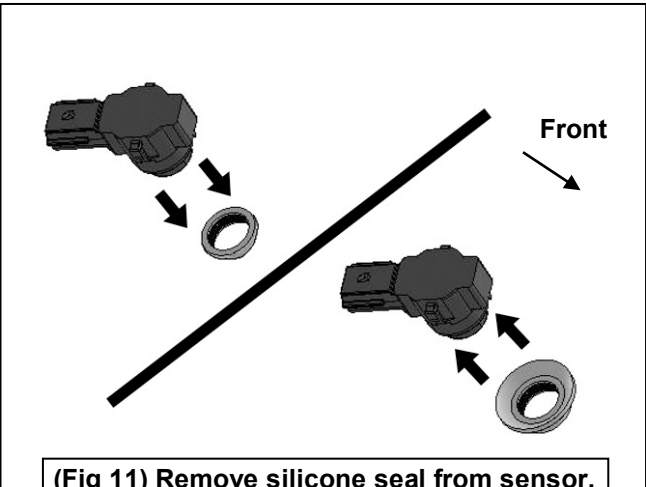

(Fig 11) Remove silicone seal from sensor.
Slide larger Seal over end of sensor

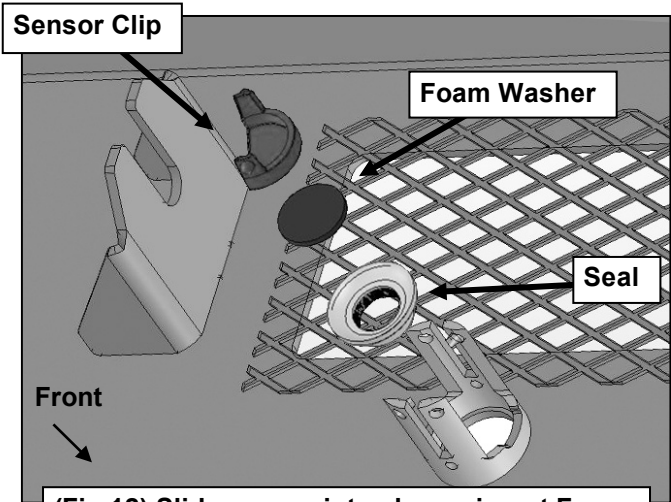

(Fig 12) Slide sensor into sleeve, insert Foam Washer and Clip to lock sensor in sleeve

Driver side installation pictured

12mm x 50mm Hex Bolt
(2) 12mm Flat Washers
12mm Lock Washer
12mm Hex Nut

WARNING! Do not crawl under bumper unless the bumper is properly supported on blocks or stands or the bumper may fall.

12mm x 160mm Hex Bolt
(2) 12mm Flat Washers
12mm Lock Washer
12mm Hex Nut

12mm x 50mm Hex Bolt
(2) 12mm Flat Washers
12mm Lock Washer
12mm Hex Nut

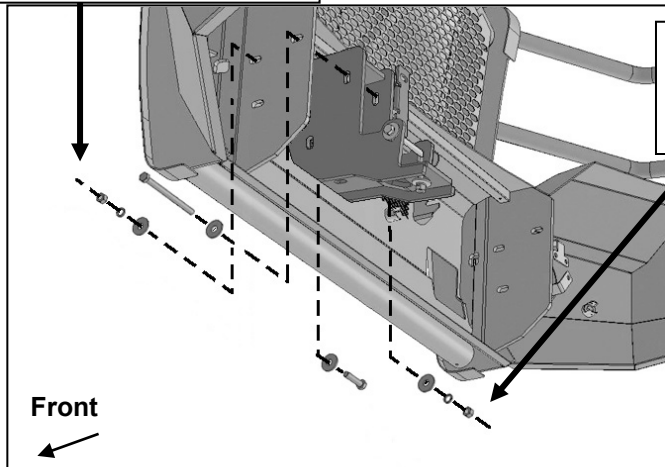

(Fig 13A) Insert long 12mm x 160mm Hex Bolt and Flat Washer into top slot in Bumper and through Bracket. Back of driver side of Bumper illustrated

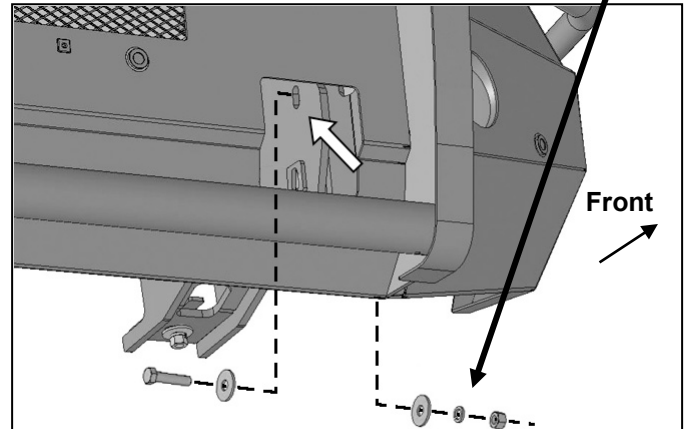

(Fig 13B) Insert 12mm x 50mm Hex Bolt and Flat Washer into opening for tow hook and out through inside slot in top of Bracket. Front of driver side of Bumper illustrated

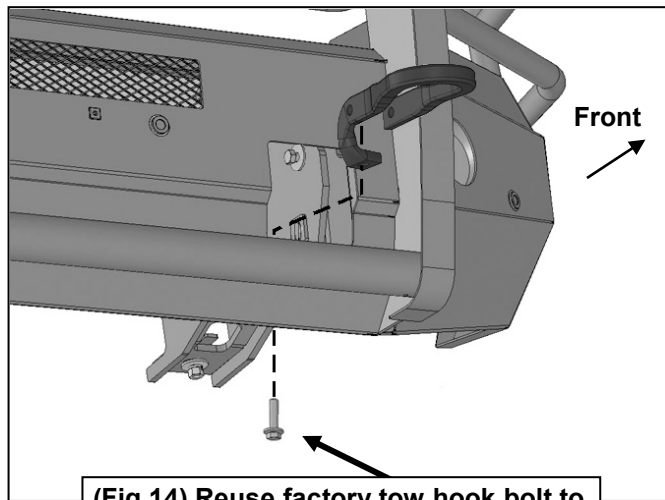

(Fig 14) Reuse factory tow hook bolt to attach tow hook to bottom of Bracket

12mm x 160mm Hex Bolt
(2) 12mm Flat Washers
12mm Lock Washer
12mm Hex Nut

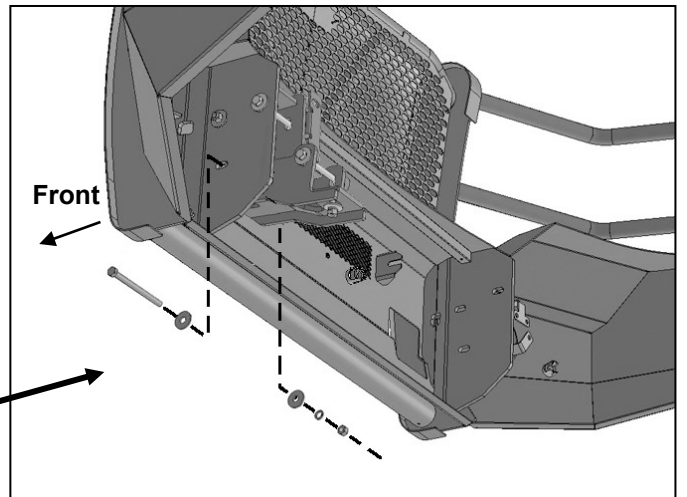

(Fig 15) Insert long 12mm x 160mm Hex Bolt with Flat Washer through Bumper, Bracket and tow hook. Back of driver side of Bumper illustrated

Driver side installation pictured



(Fig 16) Factory fog light

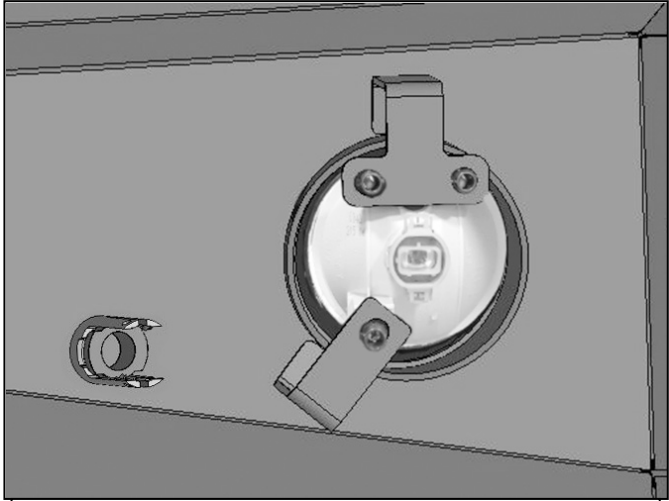

(Fig 17) Attach factory fog light to mounting tabs

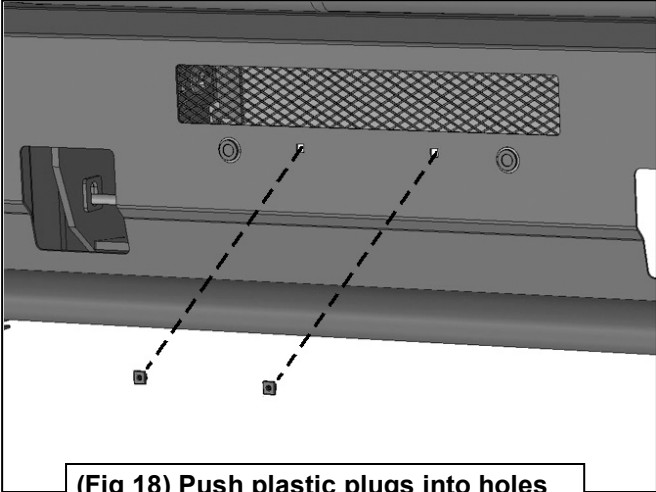

(Fig 18) Push plastic plugs into holes in Bumper for license plate if required



Complete Installation