

**MID-WIDTH FRONT BUMPER
2007-22 JEEP WRANGLER JK, JL & JT GLADIATOR**

PARTS LIST:

1	Mid Width Bumper	4	12mm Plastic Retainers
1	Bull Nose Hoop	4	10mm x 25mm Hex Bolts
1	Skid Plate	4	10mm Lock Washers
2	L-Brackets	4	10mm x 30mm OD x 2.5mm Flat Washers
2	Fog Light U-Brackets	2	8mm Bolt/Nut Plates (For JL/JT)
2	Fog Light 3-Pin Brackets	2	8mm x 35mm Bolt Plates (For JK)
1	Driver/Left LED Light Bracket	6	8mm x 25mm Button Head Bolts
1	Passenger/Right LED Light Bracket	4	8mm x 25mm Hex Bolts
1	Driver/Left Cube Light Bracket	2	8mm x 16mm Hex Bolts
1	Passenger/Right Cube Light Bracket	22	8mm x 24mm OD x 2mm Flat Washers
1	Driver/Left JL/JT Skid Plate Bracket	14	8mm Lock Washers
1	Passenger/Right JL/JT Skid Plate Bracket	10	8mm Hex Nuts
1	Driver/Left JK Skid Plate Bracket	2	8mm Plastic Retainers
1	Passenger/Right JK Skid Plate Bracket	12	4mm x 15mm Button Head Bolts
4	12mm x 35mm Bolt/Nut Plates	24	4mm x 12mm OD x 1mm Flat Washers
4	12mm x 35mm Hex Bolts	12	4mm Loc Washers
8	12mm x 37mm OD x 2.5mm Flat Washers	12	4mm Hex Nuts
8	12mm Lock Washers	1	5mm Hex Wrench
4	12mm Hex Nuts	1	4mm Hex Wrench

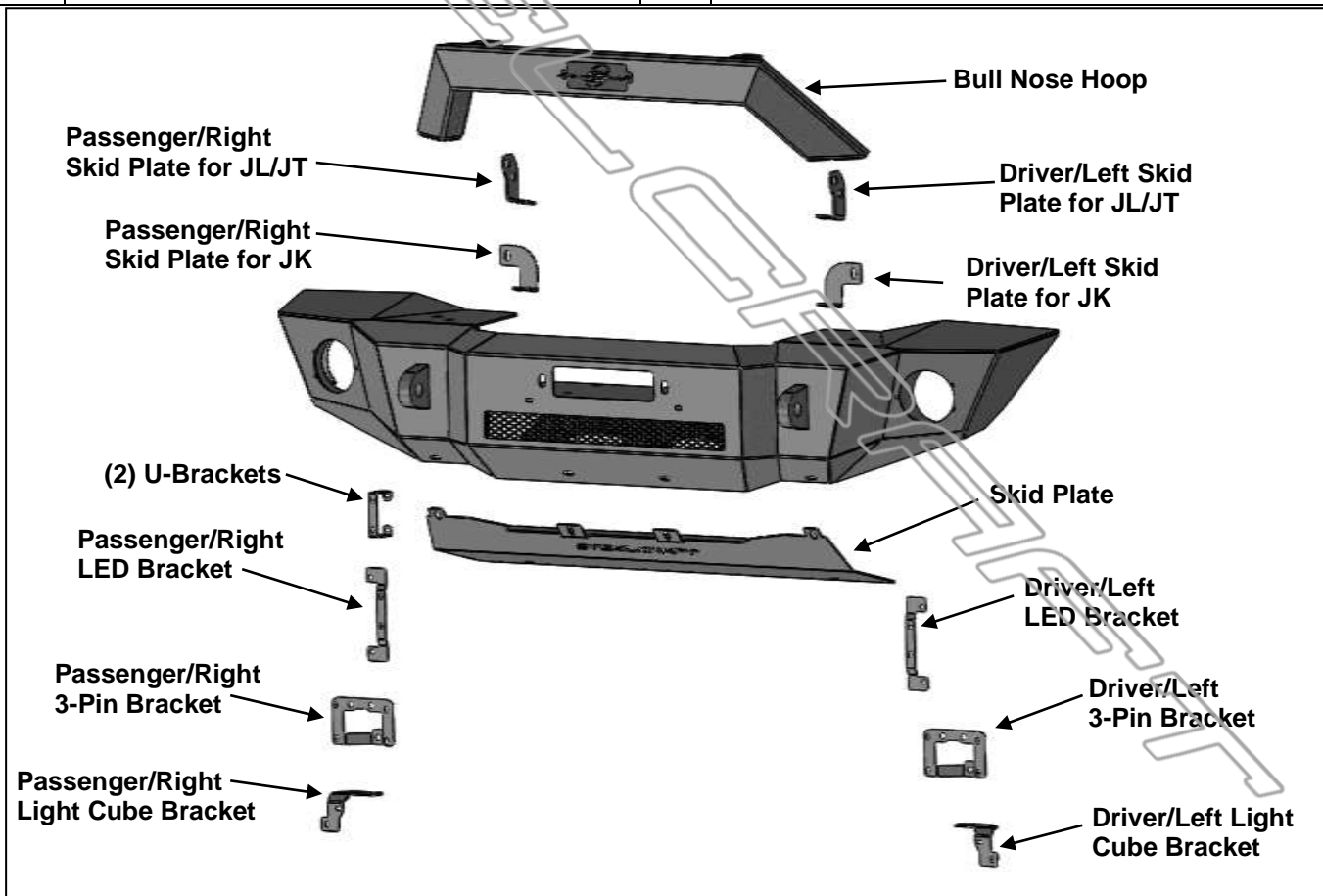

PROCEDURE: REMOVE CONTENTS FROM BOX. VERIFY ALL PARTS ARE PRESENT. READ INSTRUCTIONS CAREFULLY BEFORE STARTING INSTALLATION. ASSISTANCE IS RECOMMENDED.

1. Start under the front bumper of the vehicle and remove the plastic lower splash guard or steel skid plate, **(Figure 1)**. **NOTE:** Splash guard or skid plate cannot be reinstalled.
2. Unplug the fog light wiring harness leading to the bumper, **(Figure 2)**.

**MID-WIDTH FRONT BUMPER
2007-22 JEEP WRANGLER JK, JL & JT GLADIATOR**

3. On JK models, remove the clips fastening the plastic fill panel to the top of frame behind the bumper. Slide fill panel left or right to access bumper hardware from above, **(Figure 3)**. **NOTE:** All models, bumper mounting hardware will also be accessed from below.
4. With assistance, remove the front bumper, **(Figures 4—6)**. Move the bumper to a stable surface. Remove the fog lights and wiring harness. Depending on model and year, bumper may need to be disassembled to remove fog lights and/or wire harness.
5. Determine if Bull Nose Hoop and/or factory fog lights will be installed, (optional). **NOTE:** Bull Nose Hoop and fog lights must be attached to the Front Bumper before installing the Bumper. If Bull Nose Hoop and/or fog lights will not be installed, skip to **Step 8**.

Bull Nose Hoop Installation, (optional):

- a. Select the Bull Nose Hoop. Attach the Hoop to the top of the Bumper with the included (4) 10mm Hex Bolts, (4) 10mm Lock Washers and (4) 10mm Flat Washers, **(Figure 7)**.

Factory fog lights installation—determine fog light design first:

LED Fog Lights on Rubicon models:

- a. Select the Driver/Left LED Light Bracket.
- b. Attach the Bracket to the inner mounting plate on the back side of the Bumper with (2) 4mm Button Head Bolts, (4) 4mm Flat Washers, (2) 4mm Lock Washers and (2) 4mm Hex Nuts, **(Figure 8)**.
- c. Attach the Driver/Left LED fog light to the mounting bracket with (2) 4mm Button Head Bolts, (4) 4mm Flat Washers, (2) 4mm Lock Washers and (2) 4mm Hex Nuts. **IMPORTANT:** Do not overtighten fog light hardware or damage to the fog light may result.

4-tab “JK” and “JL” standard fog light:

- a. Select (1) U-Bracket. Attach the Bracket to the inner mounting plate on the back side of the Bumper with (2) 4mm Button Head Bolts, (4) 4mm Flat Washers, (2) 4mm Lock Washers and (2) 4mm Hex Nuts, **(Figure 9)**.
- b. Attach the Driver/Left fog light to the mounting brackets with (4) 4mm Button Head Bolts, (8) 4mm Flat Washers and (4) 4mm Nylon Lock Nuts, **(Figure 10)**. **IMPORTANT:** Do not overtighten fog light hardware or damage to the fog light may result.

2-tab 2013-17 “JK” Halogen Fog Light supplied with Mopar Option steel bumper:

- a. Remove the plastic light from the OE bumper, **(Figure 11)**.
- b. Remove the bulb assembly from the plastic bracket, **(Figure 12)**.
- c. Select (1) U-Bracket. Attach the Bracket to the mounting plate on the back of the Bumper with (2) 4mm Button Head Screws, (4) 4mm Flat Washers and (2) 4mm Nylon Lock Nuts, **(Figure 9)**.
- d. Next, select the Driver/Left 3-Pin Bracket. Attach the Bracket to the mounting plate and U-Bracket with (4) 4mm Button Head Bolts, (8) 4mm Flat Washers, (4) 4mm Lock Washers and (4) 4mm Hex Nuts, **(Figure 13)**.
- e. Push the (3) pins on the fog light bulb into the U-Adapter Bracket.
- f. Repeat to install the passenger/right fog light.

2-tab 2018-on “JK” and “JL” LED Fog Light supplied with Mopar Option steel bumper:

- a. Select (1) U-Bracket. Attach the Bracket to the mounting plate on the back of the Bumper with (2) 4mm Button Head Screws, (4) 4mm Flat Washers and (2) 4mm Nylon Lock Nuts, **(Figure 9)**.
- b. Select the Driver/Left factory fog light assembly. Rotate light assembly 90-degrees.
- c. Attach the LED light to the mounting brackets with (2) 4mm Button Head Screws, (4) 4mm Flat Washers and (2) 4mm Nylon Lock Nuts, **(Figure 13)**. **IMPORTANT:** Do not overtighten hardware or damage to the fog light may result.
- d. Select the passenger/right Adapter Bracket. Repeat previous Steps to install the passenger/right LED fog light.

3-Pin 2018-on “JL” Sport with 1pc plastic outer bumper cover & halogen fog light:

- a. Remove the Driver/Left fog light assembly, **(Figure 14)**.
- b. Attach the Driver/Left fog light to the mounting location with (3) 4mm Button Head Bolts, (6) 4mm Flat Washers, (3) 4mm Lock Washers and (3) 4mm Hex Nuts, **(Figure 15)**. **IMPORTANT:** Do not overtighten fog light hardware or damage to the fog light may result. **NOTE:** No U-Brackets required.
- c. Select the passenger/right fog light assembly. Repeat previous Steps to install the passenger/right fog light.

MID-WIDTH FRONT BUMPER
2007-22 JEEP WRANGLER JK, JL & JT GLADIATOR

6. Repeat **Step 5** to attach the Passenger Right fog light.
7. Install factory fog light wiring harness into back of Bumper.
8. **LED light bar installation, (LED light bar sold separately).**
 - a. Select (2) L-Brackets. Attach the L-Brackets to the underside of the winch mounting plate with (2) 8mm x 25mm Hex Bolts, (4) 8mm Flat Washers, (2) 8mm Lock washers and (2) 8mm Hex Nuts, **(Figure 16)**.
 - b. Next, attach the light bar to the L-Brackets with the (2) 8mm x 16mm Hex Bolts, (2) 8mm Lock Washers and (2) 8mm Flat Washers, **(Figure 16)**.
 - c. Follow light bar manufacturer's instructions for wiring.
9. **Winch Installation, (winch not included):**
 - a. Attach the winch to the winch mounting plate.
 - b. Follow winch manufacturer's instructions for wiring.
10. **For Bumper mounting:**
 - a. Select the (4) 12mm Bolt/Nut Plates. Insert the Bolt/Nut Plates into the mounting plates on the back of the Bumper, **(Figure 17)**.
 - b. Thread (4) 12mm Plastic Retainers onto the threads of the Bolt/Nut Plates to hold them in place, **(Figure 17)**.
 - c. With assistance, hold the Bumper up in place. Temporarily support the weight of the Bumper.
WARNING: To avoid possible injury or damage to the vehicle, do not proceed until the Bumper is fully and safely supported.
 - d. Attach the Bumper to the top of the frame mounting plates with (4) 12mm Flat Washers, (4) 12mm Lock Washers and (4) 12mm Hex Nuts, **(Figure 18)**.
 - e. Attach the Bumper to the bottom of the frame mounting plates with (4) 12mm Hex Bolts, (4) 12mm Lock Washers and (4) 12mm Flat Washers, **(Figure 18)**.
11. **For Skid Plate installment:**

For JK models:

 - a. Select the Driver/Left JK Skid Plate Bracket.
 - b. Attach the Bracket to the outer hole in the back of the crossbar on the bottom of the frame with (1) 8mm Bolt Plate, (1) 8mm Flat Washer, (1) 8mm Lock Washer and (1) 8mm Hex Nut, **(Figure 20)**. Repeat this **Step** to attach the Passenger/Right JK Skid Plate Bracket.
 - c. Select the Skid Plate.
 - d. Attach the Skid Plate to the back lower rear of the Bumper with (4) 8mm Button Head Bolts, (8) 8mm Flat Washers, (4) 8mm Lock Washers and (4) 8mm Hex Nuts, **(Figure 23)**.
 - e. Attach the Skid Plate to the Skid Plate Brackets with (2) 8mm Button Head Bolts, (4) 8mm Flat Washers, (2) 8mm Lock Washers and (2) 8mm Hex Nuts, **(Figure 24)**.

For JL/JT models:

 - a. Select (1) 8mm Bolt/Nut Plate.
 - b. Insert the Bolt/Nut Plate up into the frame and out the second from the bottom hole towards the center of the vehicle, **(Figure 21)**.
 - c. Thread (1) 8mm Plastic Retainer to the threads of the Bolt/Nut Plate to hold it in place.
 - d. Attach the Driver/Left JL/JT Skid Plate Bracket to the Bolt/Nut Plate with (1) 8mm Hex Bolt, (2) 8mm Lock Washers, (2) 8mm Flat Washers and (1) 8mm Hex Nut, **(Figure 22)**.
 - e. Select the Skid Plate.
 - f. Attach the Skid Plate to the back lower rear of the Bumper with (4) 8mm Button Head Bolts, (8) 8mm Flat Washers, (4) 8mm Lock Washers and (4) 8mm Hex Nuts, **(Figure 23)**.
 - g. Attach the Skid Plate to the Skid Plate Brackets with (2) 8mm Button Head Bolts, (4) 8mm Flat Washers, (2) 8mm Lock Washers and (2) 8mm Hex Nuts, **(Figure 24)**.
12. Stand back from the vehicle and check to see that the Bumper is centered and level on the vehicle and adjust as required. Once properly aligned, fully tighten all hardware.
13. Push (2) Plastic Plugs into square holes in Bumper to attach license plate, **(Figure 19)**.
14. Reattach the wiring harness for the factory fog lights. Adjust lights as necessary and fully tighten hardware. Reinstall electric sway bar if equipped and previously removed.
15. Do periodic inspections of the installation to make sure that all hardware is secure and tight.

**MID-WIDTH FRONT BUMPER
2007-22 JEEP WRANGLER JK, JL & JT GLADIATOR**

To protect your investment, Do not use any type of polish or wax that may contain abrasives that could damage the finish. Mild soap may be used to clean the Front Bumper.

Driver/Left Side Installation Pictured

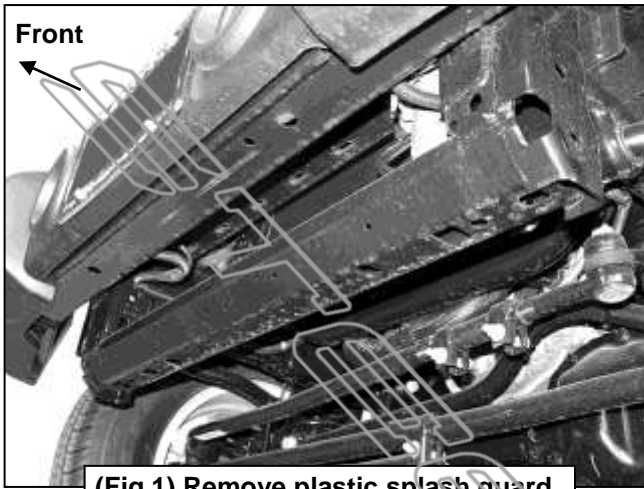

(Fig 1) Remove plastic splash guard or skid plate from bottom of bumper



(Fig 2) Unplug the wiring harness leading to the front bumper (arrow-JL passenger side pictured)

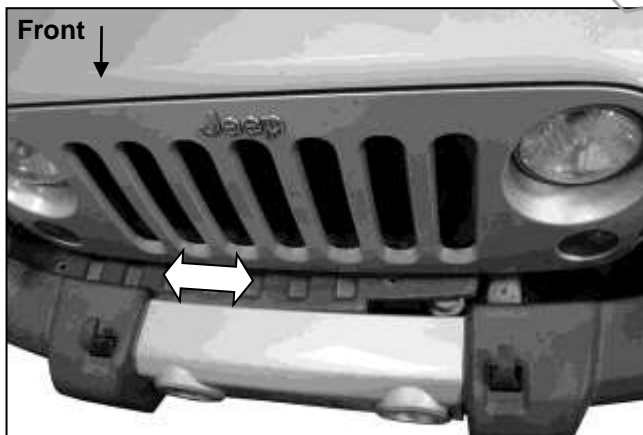

(Fig 3) JK models-Remove clips attaching fill panel to top of frame. Slide panel left or right to access bumper bolts from above

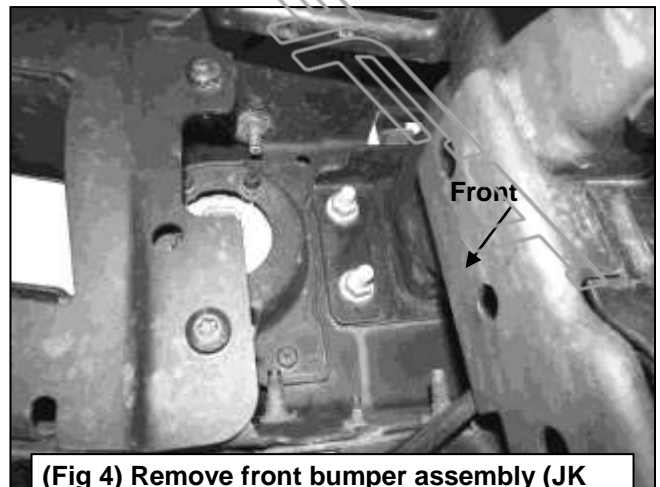

(Fig 4) Remove front bumper assembly (JK passenger side inner bumper bolts pictured)

**MID-WIDTH FRONT BUMPER
2007-22 JEEP WRANGLER JK, JL & JT GLADIATOR
Driver/Left Side Installation Pictured**



(Fig 5) Front Bumper and splash guard removed from vehicle (JK pictured)



(Fig 6) Remove front bumper and splash guard or skid plate (2018-on JL pictured)

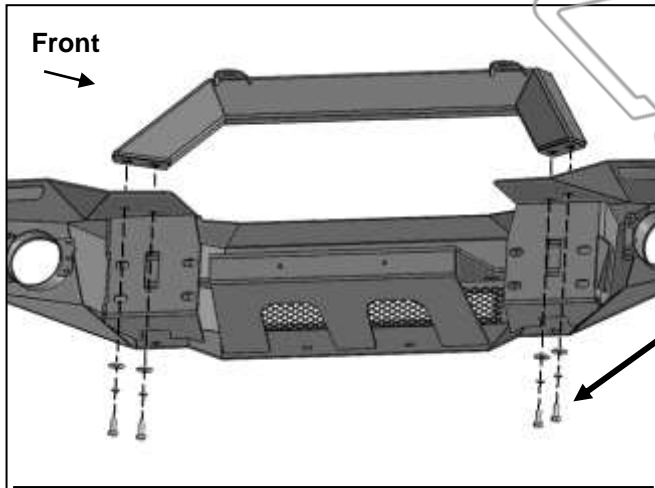

(Fig 7) Attach Bull Nose Hoop to top of Bumper

- (4) 10mm Hex Bolts**
- (4) 10mm Lock Washers**
- (4) 10mm Flat Washers**

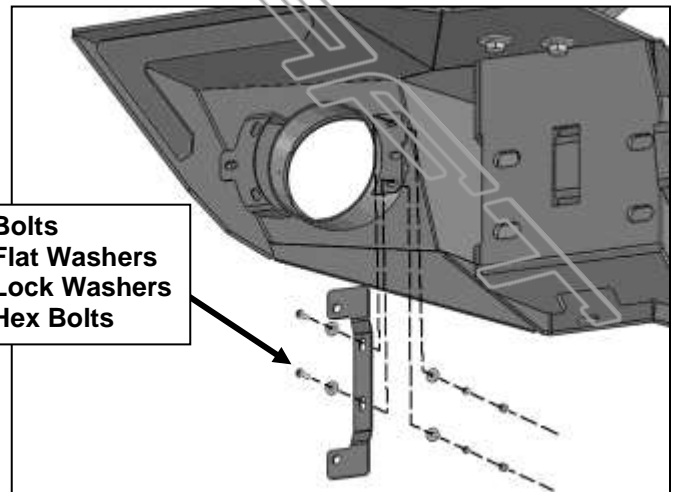

- (2) 4mm Bolts**
- (4) 4mm Flat Washers**
- (2) 4mm Lock Washers**
- (2) 4mm Hex Bolts**

(Fig 8) LED Fog Lights, attach the Driver/Left LED Light Bracket to the mounting plate

**MID-WIDTH FRONT BUMPER
2007-22 JEEP WRANGLER JK, JL & JT GLADIATOR
Driver/Left Side Installation Pictured**

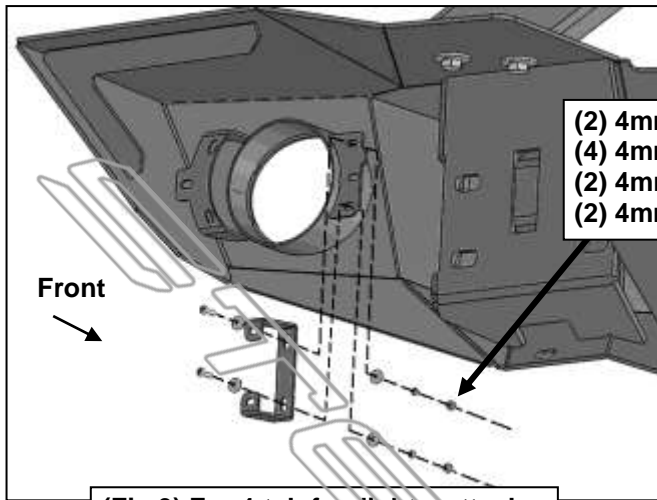

(Fig 9) For 4-tab fog lights, attach (1) U-Bracket to the mounting plate

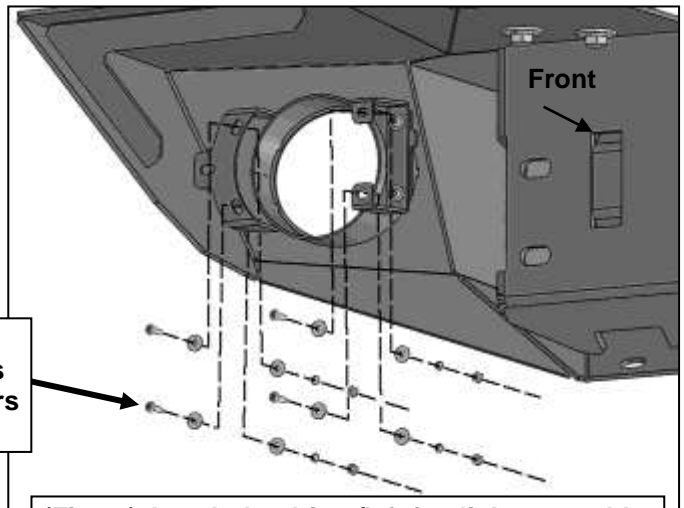

(Fig 10) Attach the driver/left fog light assembly to the Adapter Bracket and mounting plate

2013-17 JK models with steel Mopar option bumper and 2-tab, halogen fog light assembly, remove assembly from bumper

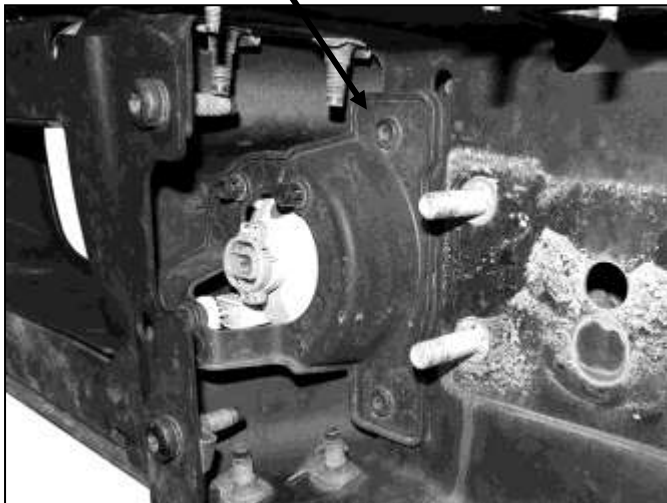

(Fig 11) 2013-17 JK models with steel Mopar option bumper (passenger/right side pictured)

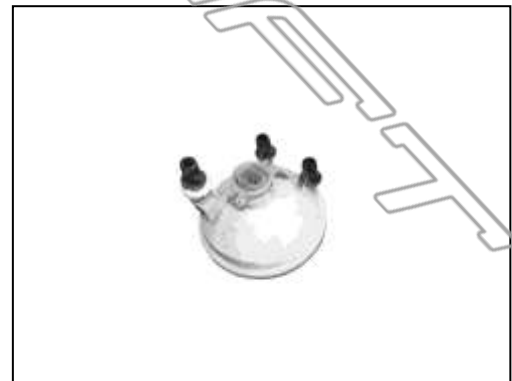

(Fig 12) Remove the fog light bulb from the plastic bracket assembly (see Figure 11)

**MID-WIDTH FRONT BUMPER
2007-22 JEEP WRANGLER JK, JL & JT GLADIATOR
Driver/Left Side Installation Pictured**

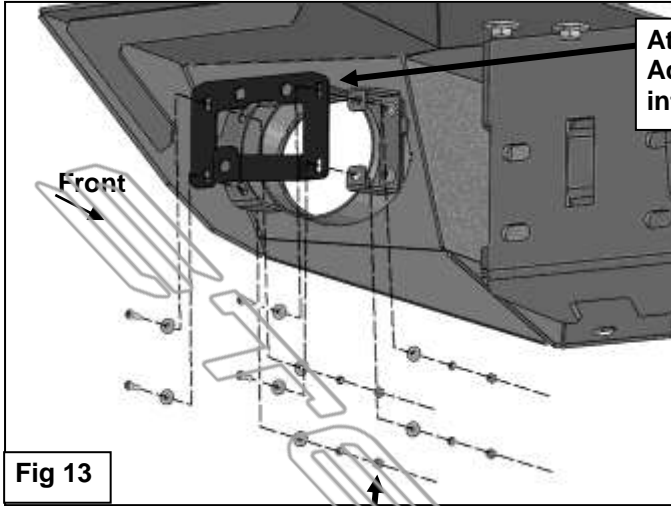

Attach U-Bracket to mounting plate and Adapter Bracket. Push 3 pins on bulb (Fig 12) into U-Bracket (driver/left side illustrated)

Fig 13

- (4) 4mm Bolts
- (8) 4mm Flat Washers
- (4) 4mm Lock Washers
- (4) 4mm Hex Nuts

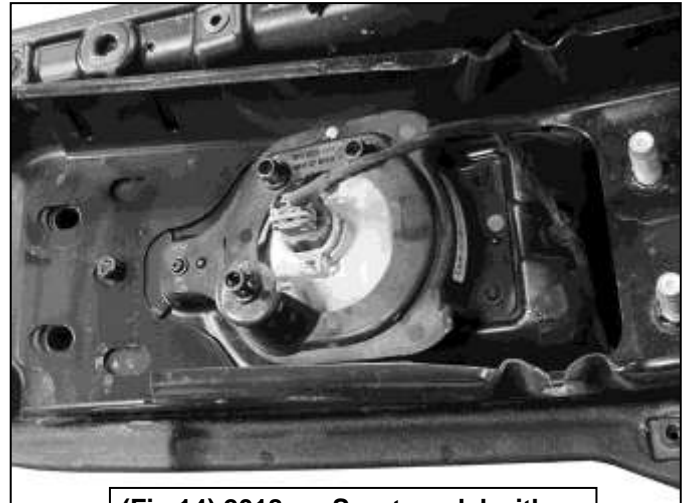

(Fig 14) 2018-on Sport model with 1pc plastic bumper cover. Driver/left Fog light assembly pictured

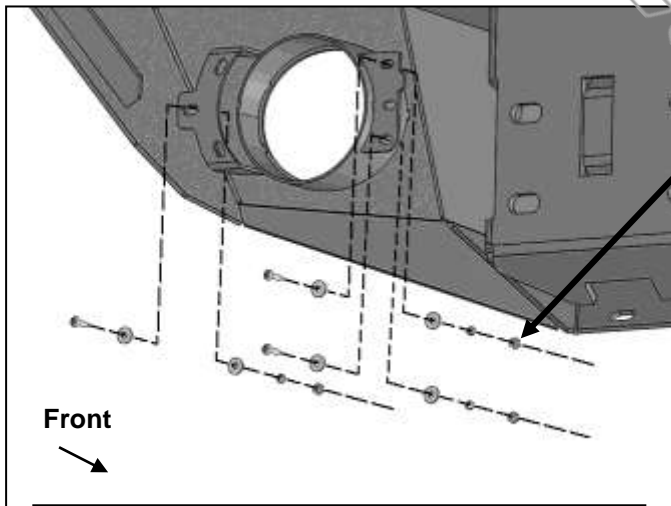

- (3) 4mm Bolts
- (6) 4mm Flat Washers
- (3) 4mm Lock Washers
- (3) 4mm Hex Nuts

- 8mm x 25mm Hex Bolt
- 8mm Flat Washers
- 8mm Lock Washer
- 8mm Hex Nut

(Fig 15) Attach 2018-on Sport model fog light assembly to mounting plates, no adapters required. Driver/left side of Bumper illustrated

- 8mm x 16mm Hex Bolt
- 8mm Lock Washer
- 8mm Flat Washer

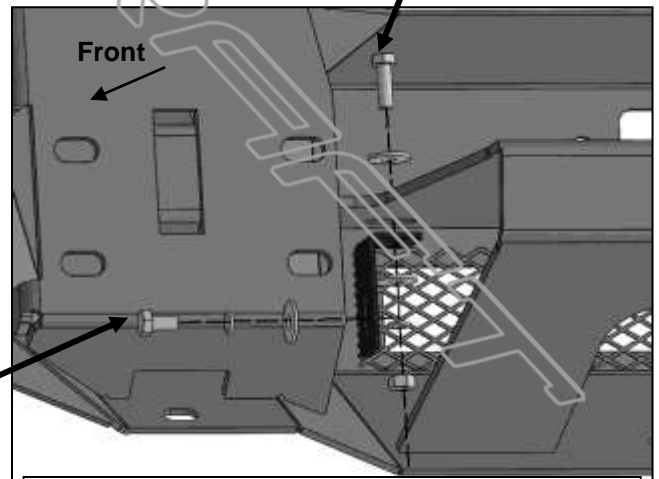

(Fig 16) Attach light bar (not included) with Brackets to mounting tabs on back of Bumper

MID-WIDTH FRONT BUMPER
2007-22 JEEP WRANGLER JK, JL & JT GLADIATOR

Driver/Left Side Installation Pictured

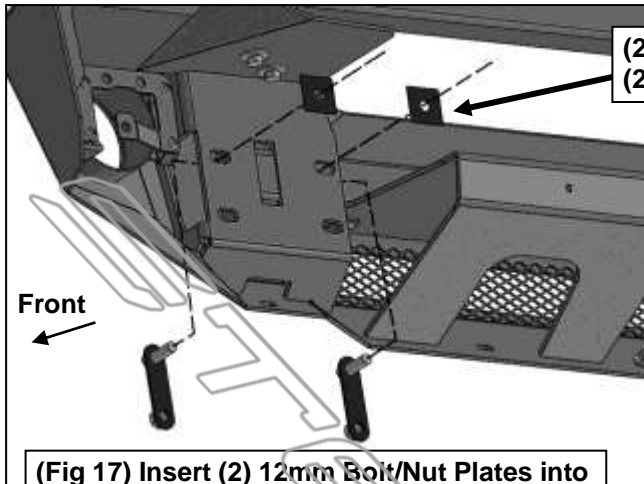

(2) 12mm Bolt/Nut Plates
(2) 12mm Plastic Retainers

(Fig 17) Insert (2) 12mm Bolt/Nut Plates into the mounting plate in the back of the bumper, (Thread (2) 12mm Plastic Retainers to hold the Bolt/Nut Plates in place)

(2) 12mm Flat Washers
(2) 12mm Lock Washers
(2) 12mm Hex Nuts

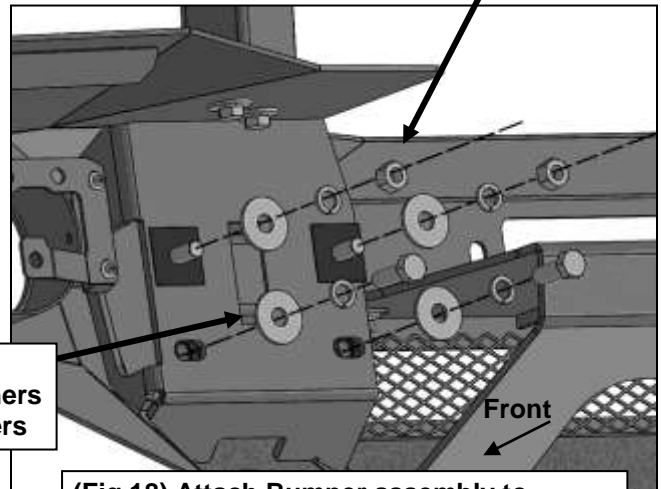

(2) 12mm Hex Bolts
(2) 12mm Lock Washers
(2) 12mm Flat Washers

(Fig 18) Attach Bumper assembly to bumper mounting plates on ends of frame

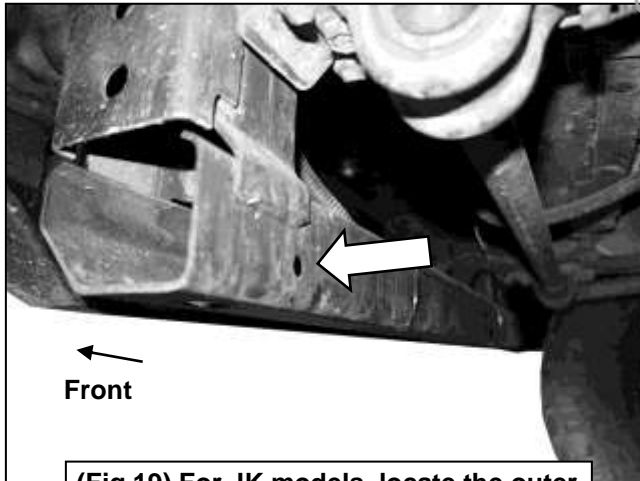

(Fig 19) For JK models, locate the outer hole in the back of the crossbar

8mm Bolt Plate
8mm Flat Washer
8mm Lock Washer
8mm Hex Nut

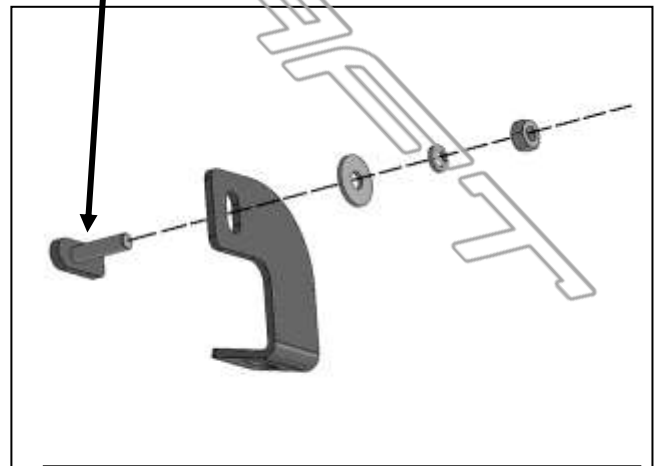

(Fig 20) For JK models, attach the Driver/Left Skid Plate Bracket to the crossbar

MID-WIDTH FRONT BUMPER
2007-22 JEEP WRANGLER JK, JL & JT GLADIATOR

Driver/Left Side Installation Pictured

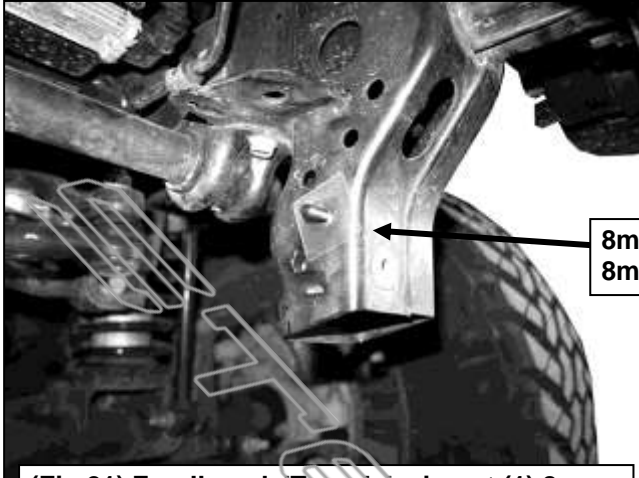

8mm Bolt/Nut Plate
8mm Plastic Retainer

8mm x 25mm Hex Bolt
8mm Lock Washer
8mm Flat Washer

(Fig 21) For JL and JT models, insert (1) 8mm Bolt Nut Plate into the bottom of the frame and out the hole shown. (Thread (2) 12mm Plastic Retainers to hold the Bolt/Nut Plates in place)

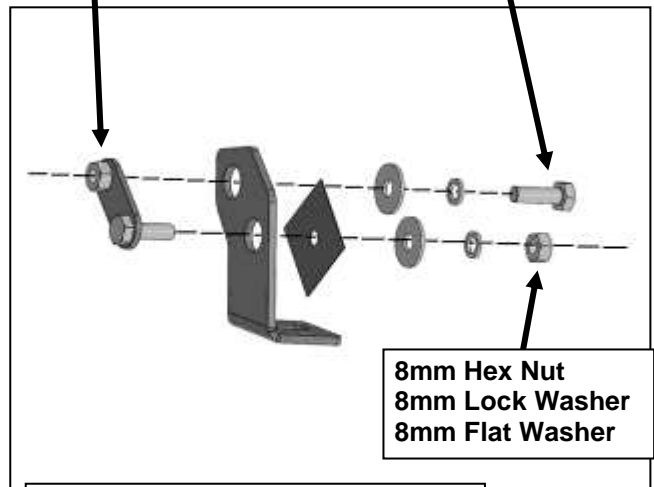

8mm Hex Nut
8mm Lock Washer
8mm Flat Washer

(Fig 22) For JL and JT models, attach the Driver/Left Skid Plate Bracket to the 8mm Bolt/Nut Plate

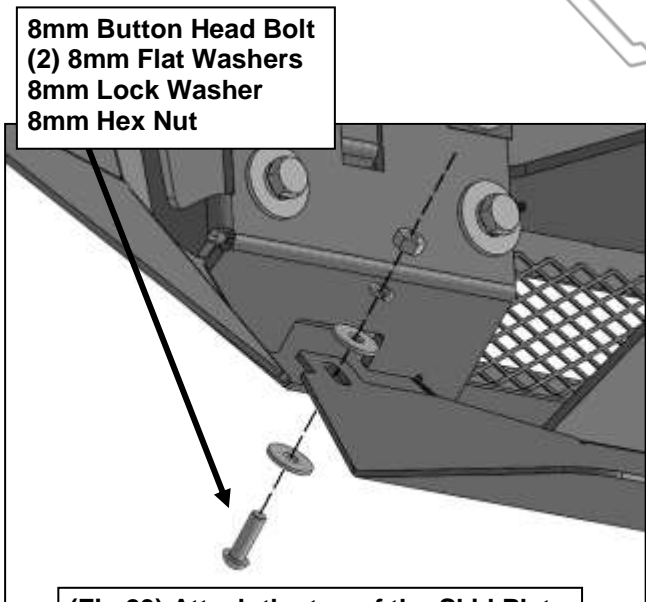

8mm Button Head Bolt
(2) 8mm Flat Washers
8mm Lock Washer
8mm Hex Nut

(Fig 23) Attach the top of the Skid Plate to the lower rear of the Bumper, (Driver/Left side shown)

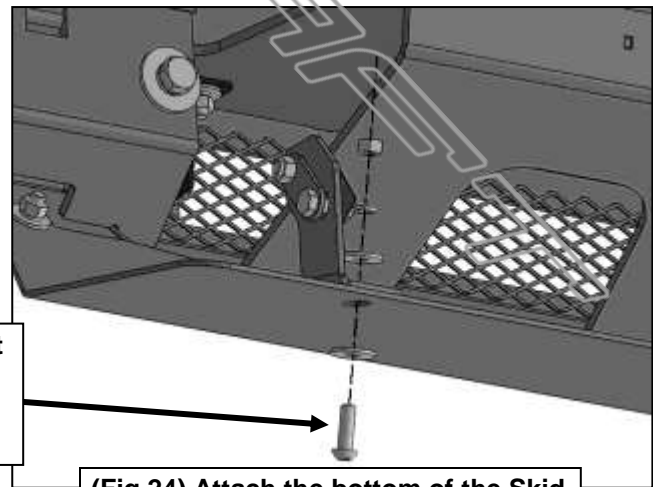

8mm Button Head Bolt
(2) 8mm Flat Washers
8mm Lock Washer
8mm Hex Nut

(Fig 24) Attach the bottom of the Skid Plate to the Skid Plate Brackets, (JL/JT model installation shown)