

**ELEVATION FRONT BUMPER OVERLAY
2015-22 KAWASAKI MULE PRO-FXT (Excludes Ranch Edition)**

PARTS LIST:

1	Elevation Front Bumper Overlay	2	8-1.25mm x 25mm Hex Bolts
1	Driver/left LED Light Bracket	2	8-1.25mm x 16mm Hex Bolts
1	Passenger/right LED Light Bracket	6	8mm x 24mm x 2mm Flat Washers
4	8-1.25mm Special Self-Tapping Flange Bolts	4	8mm Lock Washers
		2	8mm Hex Nuts

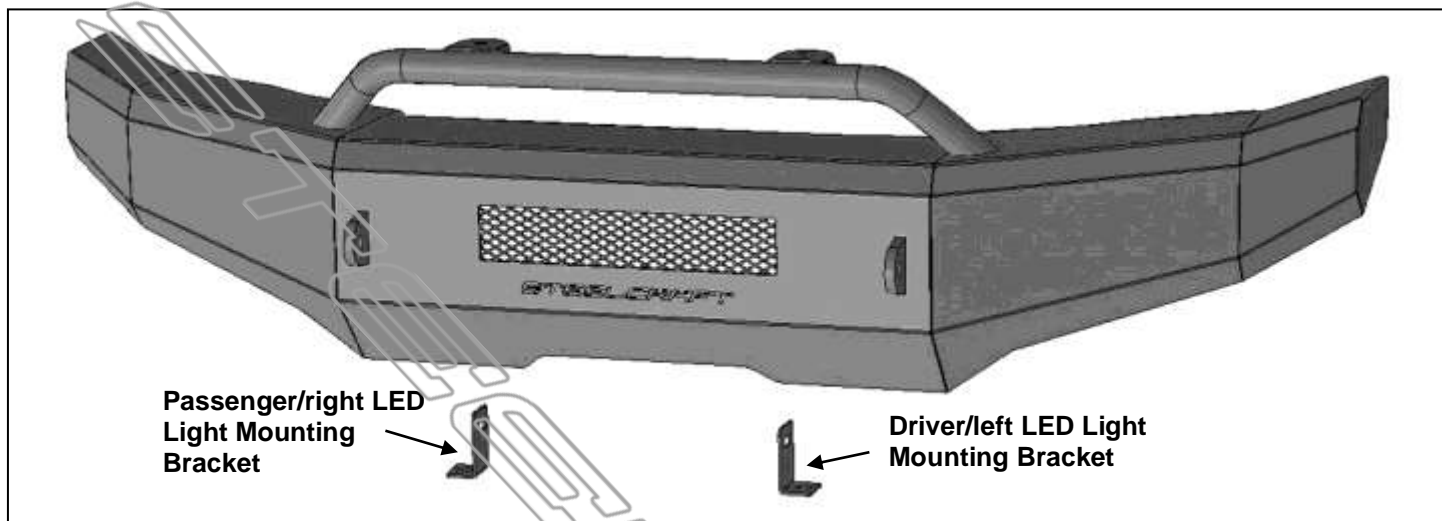

PROCEDURE:

REMOVE CONTENTS FROM BOX. VERIFY ALL PARTS ARE PRESENT. READ INSTRUCTIONS CAREFULLY BEFORE STARTING INSTALLATION. ASSISTANCE IS RECOMMENDED TO AVOID POSSIBLE INJURY OR DAMAGE TO THE VEHICLE.

1. Center LED light installation (optional-light sold separately).
 - a. Select the Left/Right "L" Brackets, **(Figure 1)**. Attach the Brackets to the top of the (2) mounting tabs welded onto the back of the bumper with the included 8mm x 25mm Hex Bolts, (4) 8mm Flat Washers, (2) 8mm Lock Washers and (2) 8mm Hex Nuts. Leave loose at this time.
 - b. Attach the LED light assembly to the "L" Brackets with the included (2) 8mm x 16mm Hex Bolts, (2) 8mm Lock Washers and (2) 8mm Flat Washers, **(Figure 1)**. Do not fully tighten hardware at this time. **IMPORTANT:** "L" Brackets are designed for 8mm light mounting hardware only. Modify "L" Brackets if necessary or use brackets supplied by the light manufacturer if possible, to install hardware larger than 8mm.
 - c. Follow light manufacturer's instructions to properly wire the light to the vehicle.
2. With assistance, position the Bumper Assembly up to the outside of the OE bumper. Line up the mounting tabs on the back of the Overlay with the holes in the vertical supports on the OE bumper, **(Figure 2)**. **WARNING:** To avoid possible injury or damage to the vehicle, do not proceed until the Bumper Overlay is fully and safely supported.
3. Attach the driver/left side of the Bumper Overlay to the outside of the support with the included (2) 8mm **Special Self-Tapping Hex Flange Bolts**, **(Figures 3 & 4)**. **IMPORTANT:** The Self Tapping Bolts feature cutting edges to thread into the holes in the support, only use the Self Tapping Bolts to attach the Overlay. Do not fully tighten hardware at this time. Repeat to attach the passenger/right side of the Bumper Overlay.
4. Level and adjust the Bumper Overlay and fully tighten all hardware.
5. Do periodic inspections to the installation to make sure that all hardware is secure and tight.

To protect your investment, Do not use any type of polish or wax that may contain abrasives that could damage the finish. Mild soap may be used to clean the Bumper Overlay assembly.

**ELEVATION FRONT BUMPER OVERLAY
2015-22 KAWASAKI MULE PRO-FXT (Excludes Ranch Edition)**

Driver/left side installation pictured

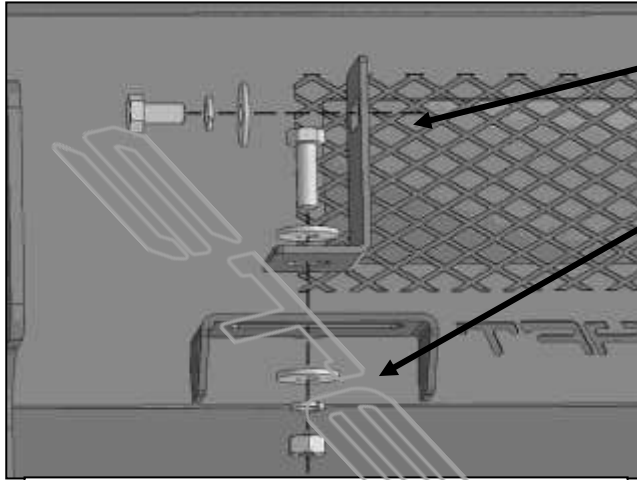

8mm x 16mm Hex Bolt
8mm Lock Washer
8mm Flat Washer

8mm x 25mm Hex Bolt
(2) 8mm Flat Washers
8mm Lock Washer
8mm Hex Nut

(Fig 1) Attach Left/Right LED Brackets to tabs on back of Bumper (left side illustrated)

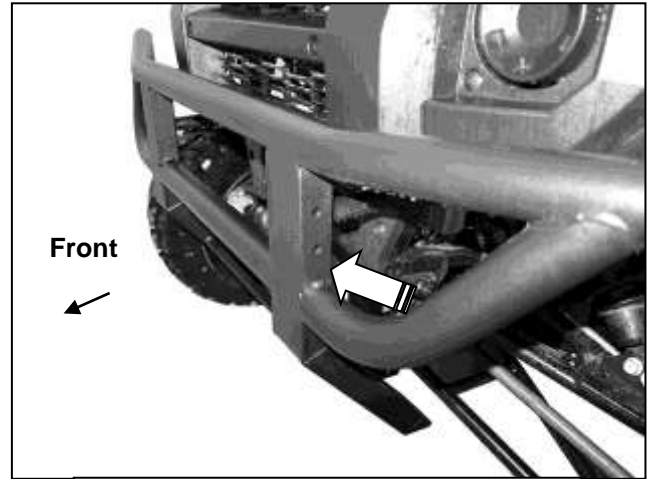

(Fig 2) Locate the holes in the vertical OE bumper supports (arrow)

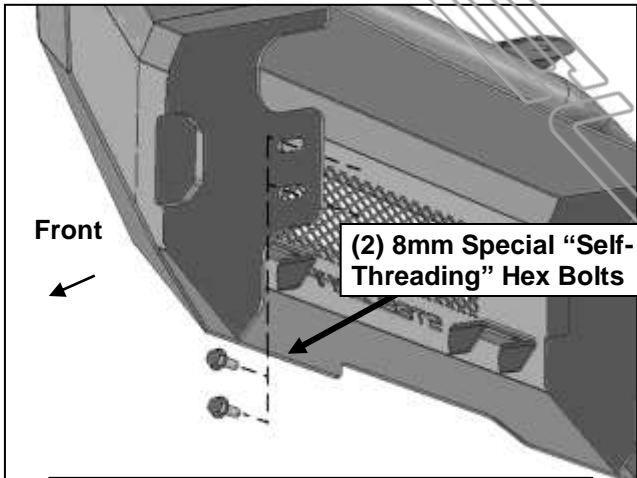

(2) 8mm Special "Self-Threading" Hex Bolts

(Fig 3) Attach tab on the driver/left side of the Overlay to the OE bumper support

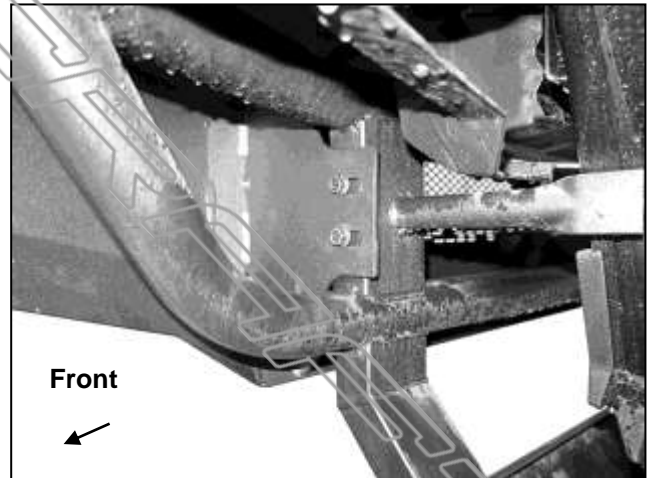

(Fig 4) Driver/left side of the Overlay attached to the OE bumper support

