

PARTS LIST:

1	Grille Guard	2	10mm Lock Washers
1	Driver/Left Frame Mounting Bracket	2	10mm Hex Nuts
1	Passenger/Right Frame Mounting Bracket	2	10mm Nylon Lock Nuts
1	Driver/Left Center Bracket	2	8mm x 25mm "Z" Bolt Plates
1	Passenger/Right Center Bracket	2	8mm x 40mm Hex Bolts
1	Driver/Left Top Bracket (07-14 models only)	2	8mm x 25mm Button Head Bolts
1	Passenger/Right Top Bracket (07-14 models only)	2	8mm x 24mm OD x 2mm Flat Washers
2	Driver/Passenger Top Brackets (2015-18 models)	8	8mm x 16mm OD x 1.6mm Flat Washers
2	3/4" OD x 3/8" Tall Tube Spacers (Center Bracket)	6	8mm Lock Washers
2	12mm x 16mm Tall Tube Spacers (Frame Bracket)	2	8mm Hex Nuts
6	12mm x 35mm Button Head Bolts	2	6mm x 25mm Button Head Bolts
12	12mm x 32mm OD x 3mm Flat Washers	2	6mm x 22mm OD x 2mm Flat Washers
6	12mm Lock Washers	1	8mm Hex Wrench
6	12mm Hex Nuts	1	6mm Hex Wrench
2	10mm x 45mm Hex Bolts	1	5mm Hex Wrench
2	10mm x 30mm Button Head Bolts	1	4mm Hex Wrench
8	10mm x 20mm OD x 2mm Flat Washers		

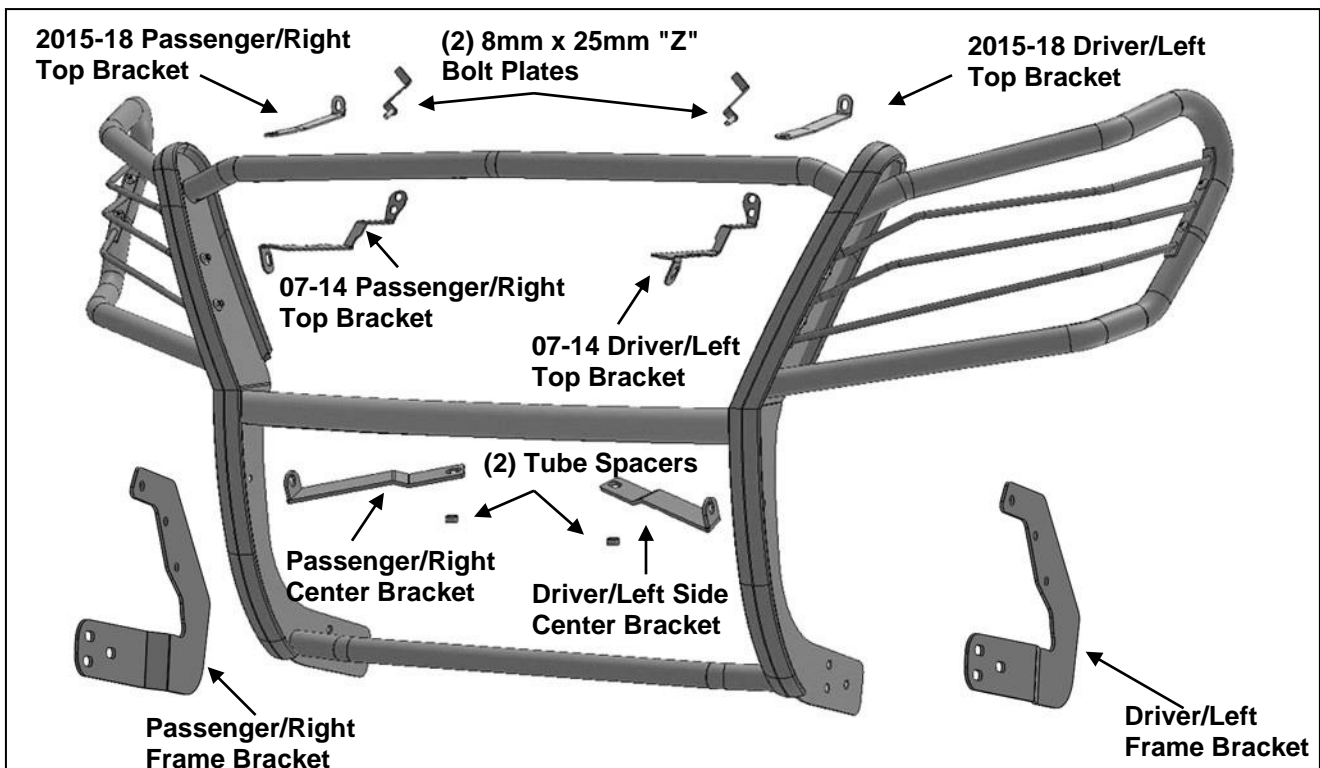

PROCEDURE:

1. REMOVE CONTENTS FROM BOX. VERIFY ALL PARTS ARE PRESENT. READ INSTRUCTIONS CAREFULLY BEFORE STARTING INSTALLATION. DRILLING IS REQUIRED. ASSISTANCE IS RECOMMENDED.
2. Starting on the driver side of the vehicle, locate the factory hole in the bottom of the frame channel, **(Figure 1)**. Insert (1) 12mm Bolt and Nut Plate into the frame rail, **(Figures 1 & 2)**. **NOTE:** Insert Bolt Plate with welded nut toward the front of the vehicle. The offset Bolt and Nut Plate is designed to clear hardware that may be attached to the inside of the frame, **(Figure 1)**.
3. Hang the driver side Frame Mounting Bracket from the Bolt and Nut Plate with (1) 12mm Flat Washer, (1) 12mm Lock Washer and (1) 12mm Hex Nut, **(Figure 3)**. Do not tighten hardware at this time.

4. Repeat **Steps 2 & 3** to install the passenger side Frame Mounting Bracket.
5. Next, remove the (2) Torx bolts in the bottom of the opening in the front bumper step area, **(Figure 4)**. Place a 3/4inch Tube Spacer into the driver side recess in the bumper cover, **(Figure 5A & 5B)**. Position the driver side Center Bracket over the Tube Spacer. Use the included 8mm x 40mm Hex Bolt, 8mm Lock Washer and 8mm x 24mm Large Flat Washer to attach the Bracket to the bumper, **(Figure 6)**. Do not tighten hardware at this time. Repeat this **Step** for passenger side Center Bracket installation.
6. With assistance, position the Grille Guard up to the outside of the Frame Mounting Brackets. Line up the rear-most holes in the Mounting Brackets with the Grille Guard. Insert (1) 12mm x 30mm Button Head Bolt, (1) 12mm Lock Washer, (2) 12mm Flat Washers and (1) 12mm Hex Nut per side into the rear mounting holes to act as a hinge. Rotate the Grille Guard up into position. Install the included 12mm Button Head Bolts into the remaining mounting holes, **(Figure 7)**. Do not tighten hardware at this time.
7. Attach the driver side Center Bracket to the Grille Guard with the included (1) 10mm x 30mm Button Head Bolt, (2) 10mm Flat Washers and (1) 10mm Nylon Lock Nut, **(Figure 8)**. Do not tighten hardware at this time. Repeat this Step for passenger side Center Bracket installation.

Determine correct procedure for Top Support Bracket installation for your model year.

2007-14 models:

- a. Open the hood and locate the factory hole in the driver side of the radiator cross member. Remove the factory screw below the hole securing the top of the grille to the cross member, **(Figure 9)**.
- b. Insert (1) 8mm "Z" Bolt Plate through the back of the cross member and out of the hole, **(Figures 10 & 11)**. **NOTE:** The back of the cross member may be obstructed. Carefully move the coolant tank or air intake if necessary to access the back of the cross member.
- c. Use 2-3 8mm x 16mm Flat Washers on the "Z" Bolt Plate as a spacer between the cross member and the Top Bracket, **(Figure 12)**. **NOTE:** It may be necessary to push down slightly on the top of the grille to provide clearance for the Spacer Washers.
- d. Secure the Top Bracket to the 8mm Bolt Plate using (1) 8mm x 16mm Flat Washer, (1) 8mm Lock Washer and (1) 8mm Hex Nut, **(Figure 13)**. Reinstall the factory screw through the hole in the Top Bracket, **(Figure 13)**. Leave hardware loose at this time.
- e. Remove the top 6mm Button Head Bolt securing the headlight wire assembly to the Grille Guard upright, **(Figure 14)**. Bolt the Top Support Bracket to the inside of the upright using the included longer 6mm x 25mm Button Head Bolt, 6mm STD Flat Washer (outside), 6mm x 22mm Large Flat Washer, (inside against the Top Bracket), and 6mm Nylon Lock Nut, **(Figures 14 & 15)**.
- f. Repeat the above Steps for passenger side Top Bracket installation.

2015-18 models:

- a. Open the hood and locate the driver side of the radiator cross member. Remove the plastic retaining clip attaching the top of the grille to the cross member, **(Figure 16)**.
 - b. Insert (1) 8mm "Z" Bolt Plate through the back of the cross member and out of the hole, **(Figure 17)**. **NOTE:** The back of the cross member may be obstructed. Carefully move the coolant tank or air intake if necessary to access the back of the cross member.
 - c. Select (1) 2015-18 Top Bracket. Attach the Top Bracket to the 8mm Bolt Plate with (1) 8mm x 16mm Flat Washer, (1) 8mm Lock Washer and (1) 8mm Hex Nut, **(Figures 17 & 18)**. Leave hardware loose at this time.
 - d. Line up the outer end of the Top Bracket with the threaded insert on the bottom of the top tube on the Grille Guard. Attach the Bracket to the tube with (1) 6mm x 25mm Button Head Bolt and (1) 6mm Flat Washer, **(Figure 19)**.
 - e. Repeat the above Steps for passenger side Top Bracket installation.
8. Align Grille Guard properly and tighten all hardware.
 9. Once you have the Grille Guard completely installed and properly aligned:
For 2WD models use the upper hole in both Frame Mounting Brackets as a template to mark the drilling location on the bottom of the frame channel, **(Figure 20)**.

For 4WD models use the lower hole in both Frame Mounting Brackets as a template to mark the drilling location on the bottom of the frame channel.

Do not mark the frame until after the Grille Guard has been completely installed and properly aligned and adjusted. No adjustments can be made after the frame has been drilled.

10. Remove the Grille Guard and Frame Brackets from the vehicle. **NOTE:** It is not necessary to remove the Center or Top Brackets from the vehicle.
11. Use a 1/2" drill bit to drill out the marked location, **(Figure 21)**. **IMPORTANT:** Any cutting or drilling tool may break or shatter. Government regulations require safety glasses & equipment at all times when cutting or drilling.
12. Reattach the top of the Frame Brackets to the frame. Use the included (2) 10mm x 40mm Hex Bolts, (4) 10mm Flat Washers (2) 12mm Tube Spacers, (2) 10mm Lock Washers and (2) 10mm Hex Nuts to secure the Frame Brackets to the frame, **(Figure 22)**. Re-install the Grille Guard as previously described in **Steps 2—8**. **NOTE:** Align Grille Guard properly and fully tighten all hardware.
13. Do periodic inspections to the installation to make sure that all hardware is secure and tight.

To protect your investment, wax this product after installing. Regular waxing is recommended to add a protective layer over the finish. Do not use any type of polish or wax that may contain abrasives that could damage the finish.

For stainless steel: Aluminum polish may be used to polish small scratches and scuffs on the finish. Mild soap may be used also to clean the Grille Guard.

For gloss black finishes: Mild soap may be used to clean the Grille Guard

Driver Side Installation Pictured

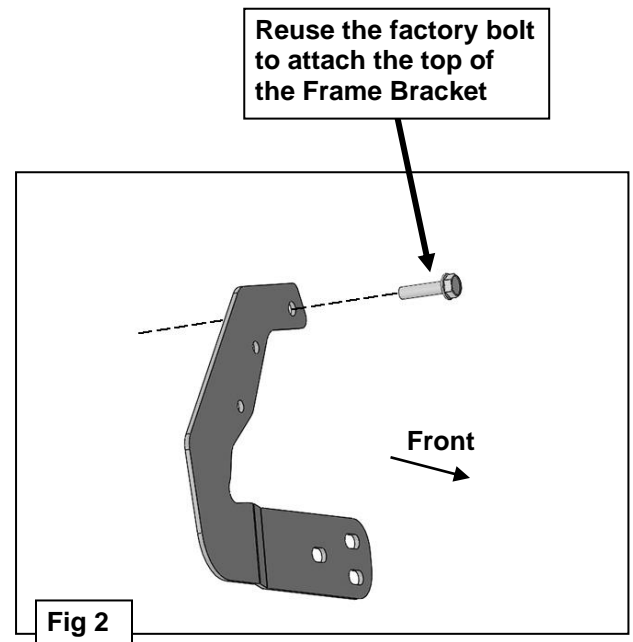
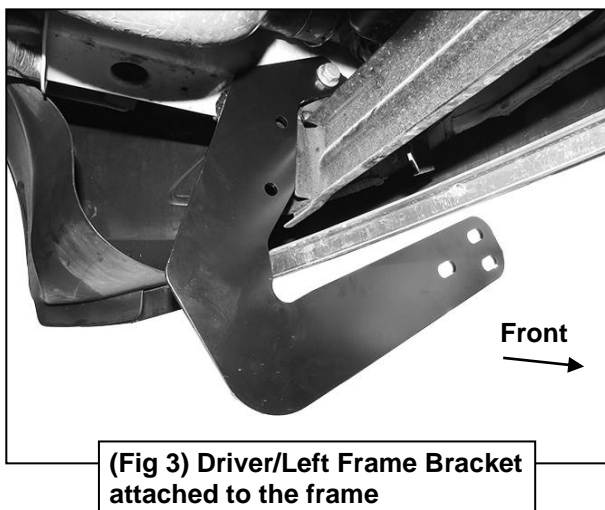
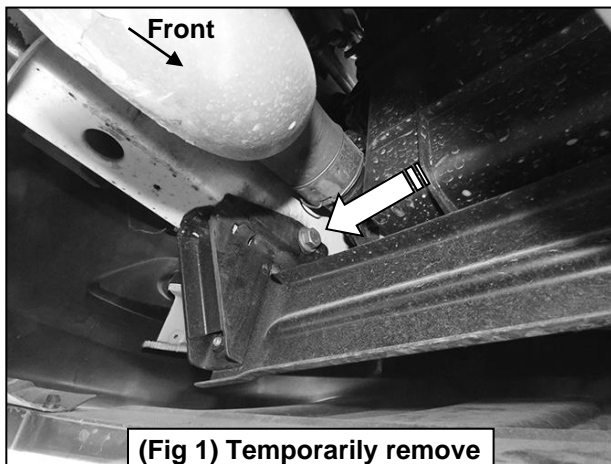

Driver Side Installation Pictured

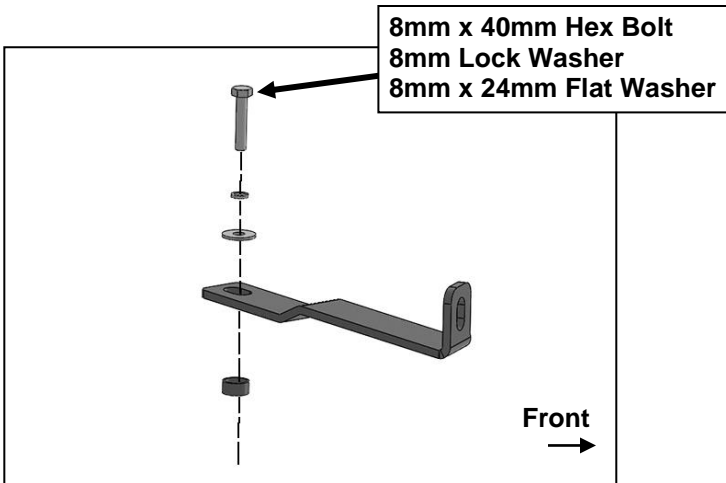
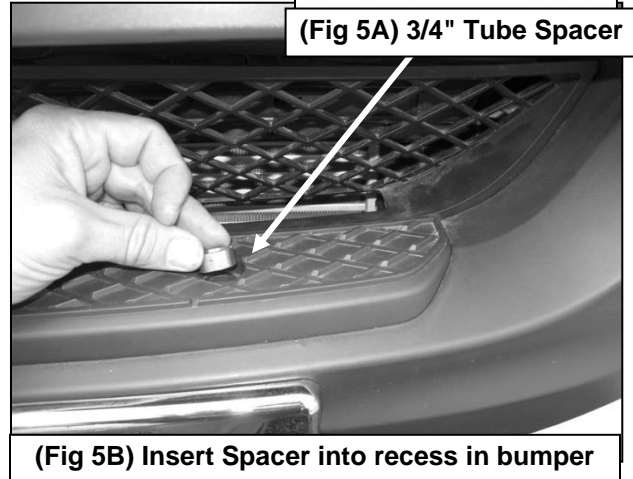
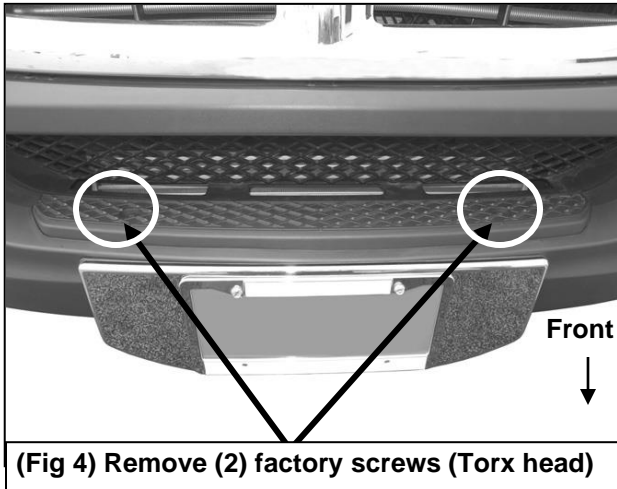

(Fig 6) Attach driver/left Center Bracket to bumper

- (3) 12mm Button Head Bolts
- (6) 12mm Flat Washers
- (3) 12mm Lock Washers
- (3) 12mm Hex Nuts

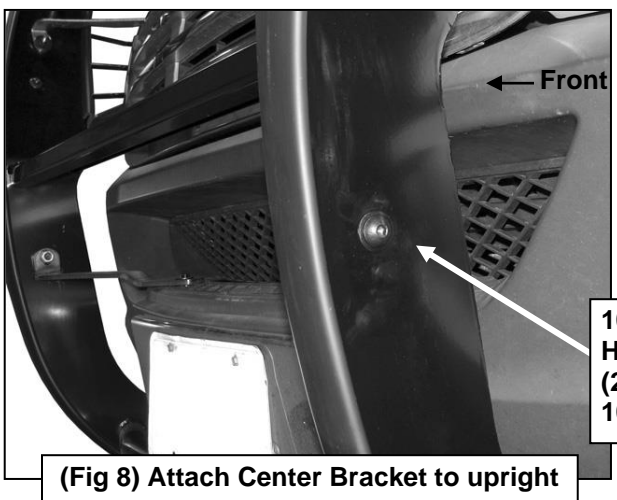
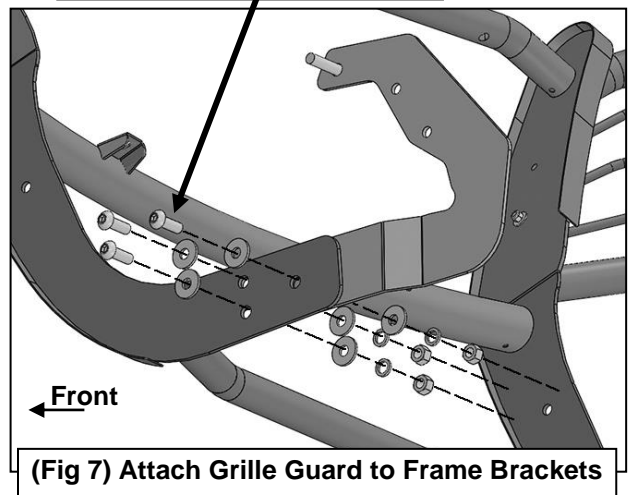

- 10mm x 30mm Button Head Bolt
- (2) 10mm Flat Washers
- 10mm Nylon Lock Nut

Driver Side Installation Pictured

Factory hole in radiator cross member (driver/left side pictured)

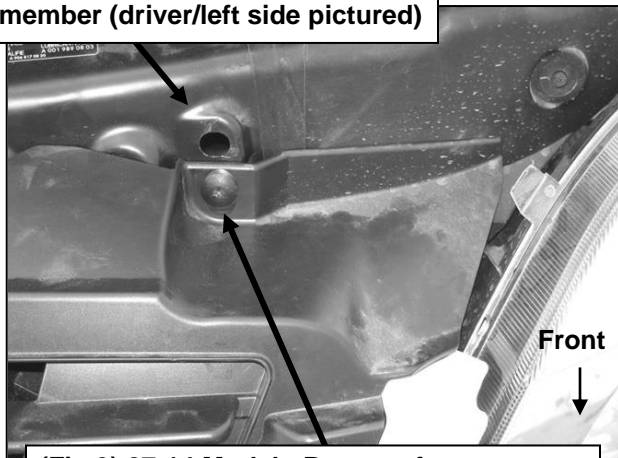

(Fig 9) 07-14 Models-Remove factory screw

Insert 8mm x 25mm "Z" Bolt Plate into the factory hole (see Fig 9) from behind the radiator cross member

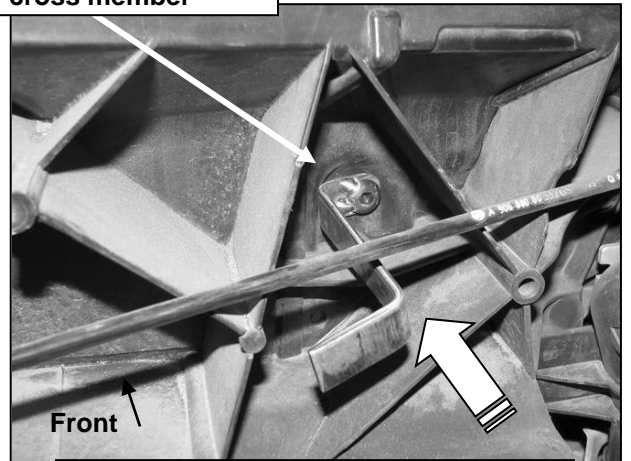

(Fig 10) Back of radiator cross member (driver/left side pictured)

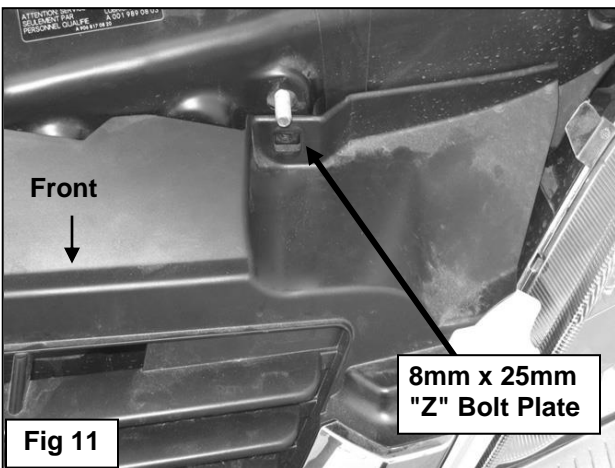

8mm x 25mm "Z" Bolt Plate

Fig 11

8mm x 16mm Flat Washer
8mm Lock Washer
8mm Hex Nut

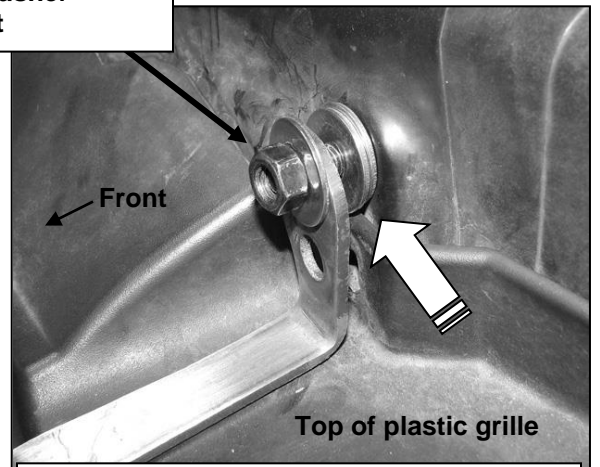

Top of plastic grille

(Fig 12) Insert (2-3) 8mm x 16mm Flat Washers as a spacer (arrow) between the Top Bracket and the radiator cross member. NOTE: It may be necessary to gently push down on the plastic grille to provide clearance for the Flat Washers/Spacer behind the Top Bracket.

Reinstall the factory button head screw (see Fig 9)

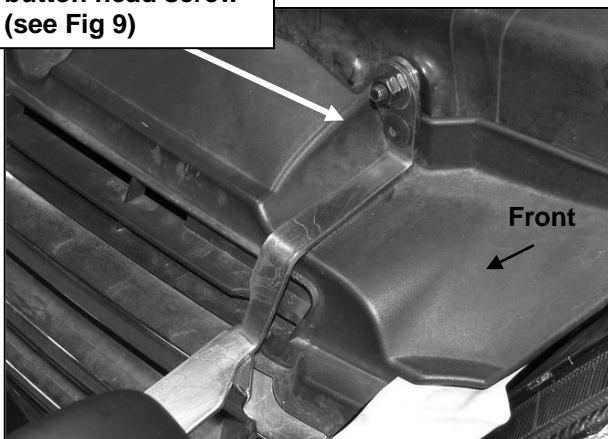

(Fig 13) 07-14 model, driver/left side pictured

Driver Side Installation Pictured

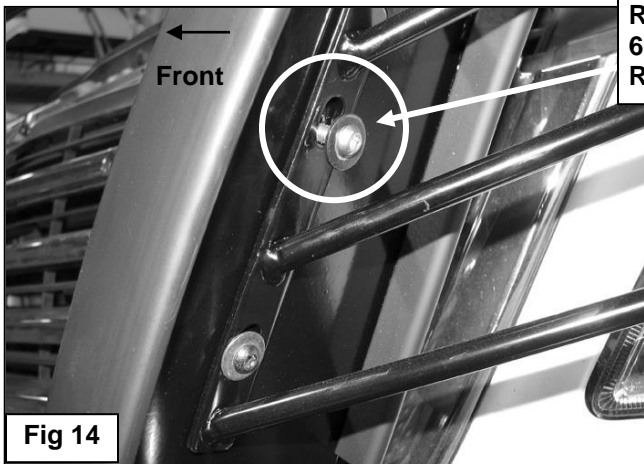

Replace top button head bolt with
6mm x 25mm Button Head Bolt
Reuse the 6mm STD Flat Washer

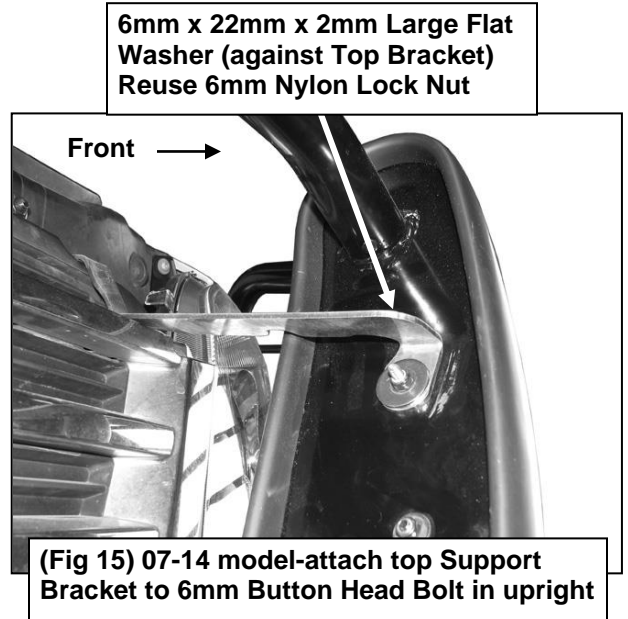

6mm x 22mm x 2mm Large Flat Washer (against Top Bracket)
Reuse 6mm Nylon Lock Nut

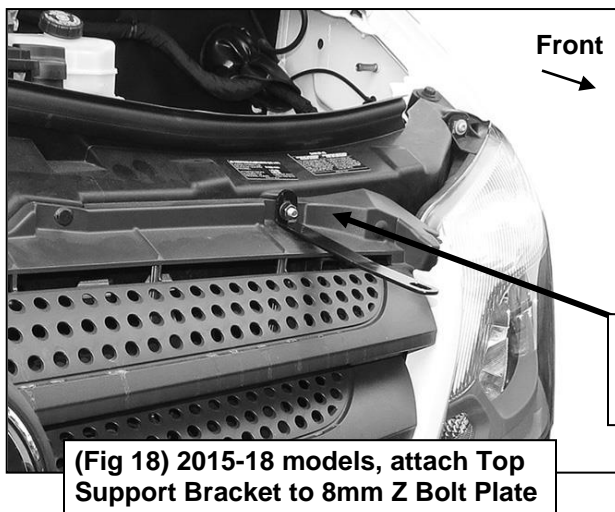
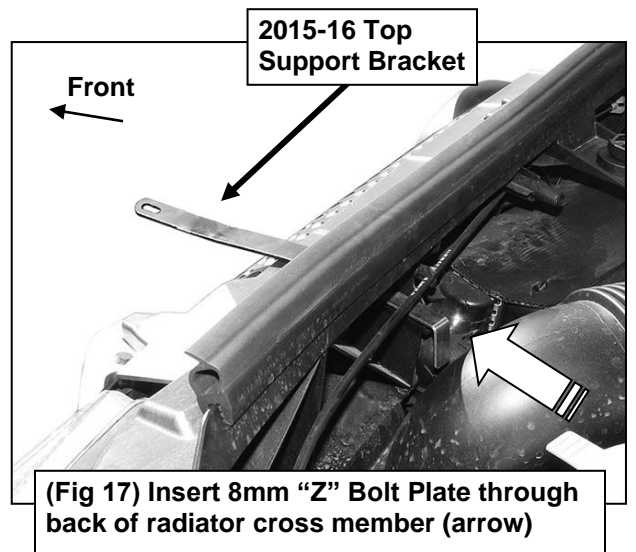
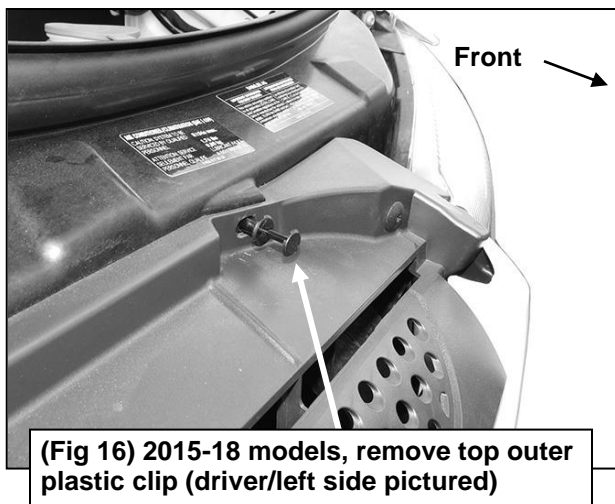

8mm x 16mm Flat Washer
8mm Lock Washer
8mm Hex Nut

Driver Side Installation Pictured

6mm x 25mm Button
Head Bolt
6mm Flat Washer



(Fig 19) 2015-18 model, driver/left side pictured

Mark hole location
onto bottom of
frame channel.
Remove Grille Guard
and Frame Brackets

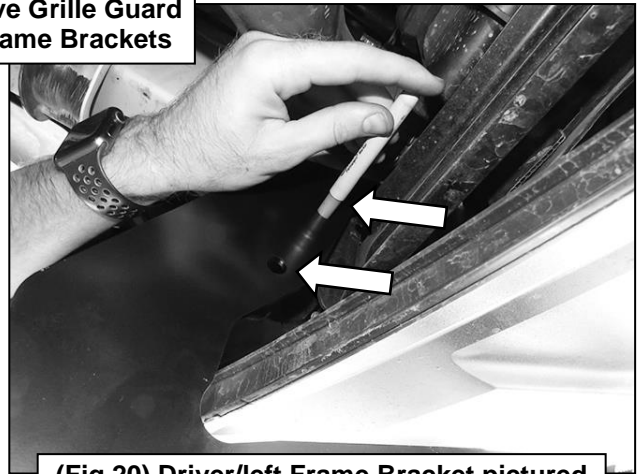

(Fig 20) Driver/left Frame Bracket pictured

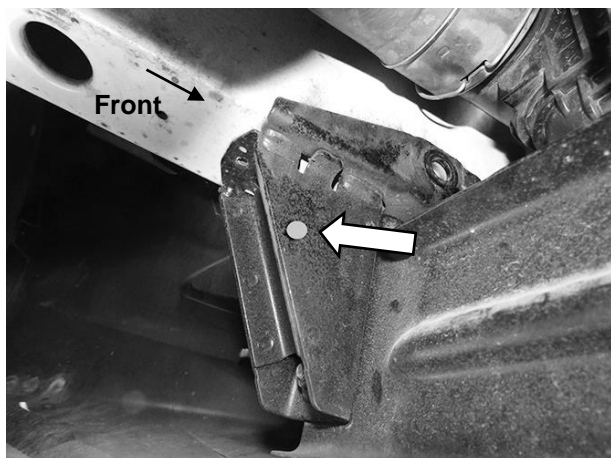

(Fig 21) Drill 1/2" hole in bottom of frame channel

10mm x 40mm Hex Bolt
(2) 10mm Flat Washers
Tube Spacer
10mm Lock Washer
10mm Hex Nut

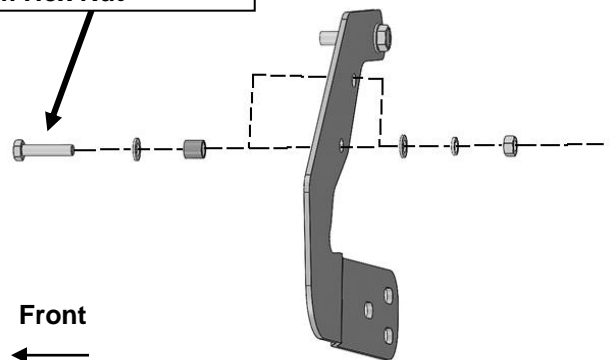

Fig 22



GRILLE GUARD
07-18 SPRINTER VAN (EXCL. 3500 DUALY AND 4500 MODELS)
INCLUDES MERCEDES, FREIGHTLINER AND DODGE