

**5" WTW SIDEBARS
2019 DODGE RAM 1500 CREW CAB**

PARTS LIST:

1	Driver/left Side 5in WTW Sidebar	2	10mm Lock Washers
1	Passenger/right Side 5in Sidebar	2	10-1.50 Hex Nuts
4	Front & Center Brackets (use left or right)	2	8-1.25mm x 30mm Hex Bolts
1	Driver/left Side Rear Bracket	12	8-1.25mm x 25mm Combo Bolts
1	Passenger/right Side Rear Bracket	16	8mm x 24mm x 2mm Flat Washers
1	Driver/left Side Rear Support Bracket	14	8-1.25mm Nylon Lock Nuts
1	Passenger/right Side Rear Support Bracket	2	6-1.00mm x 30mm Hex Bolts
2	10-1.50mm Bolt Plate	4	6mm x 18mm x 1.6mm Flat Washers
2	10mm Plastic Retainers	2	6-1.00mm Nylon Lock Nuts
2	10mm x 30mm x 2.5mm Flat Washers		

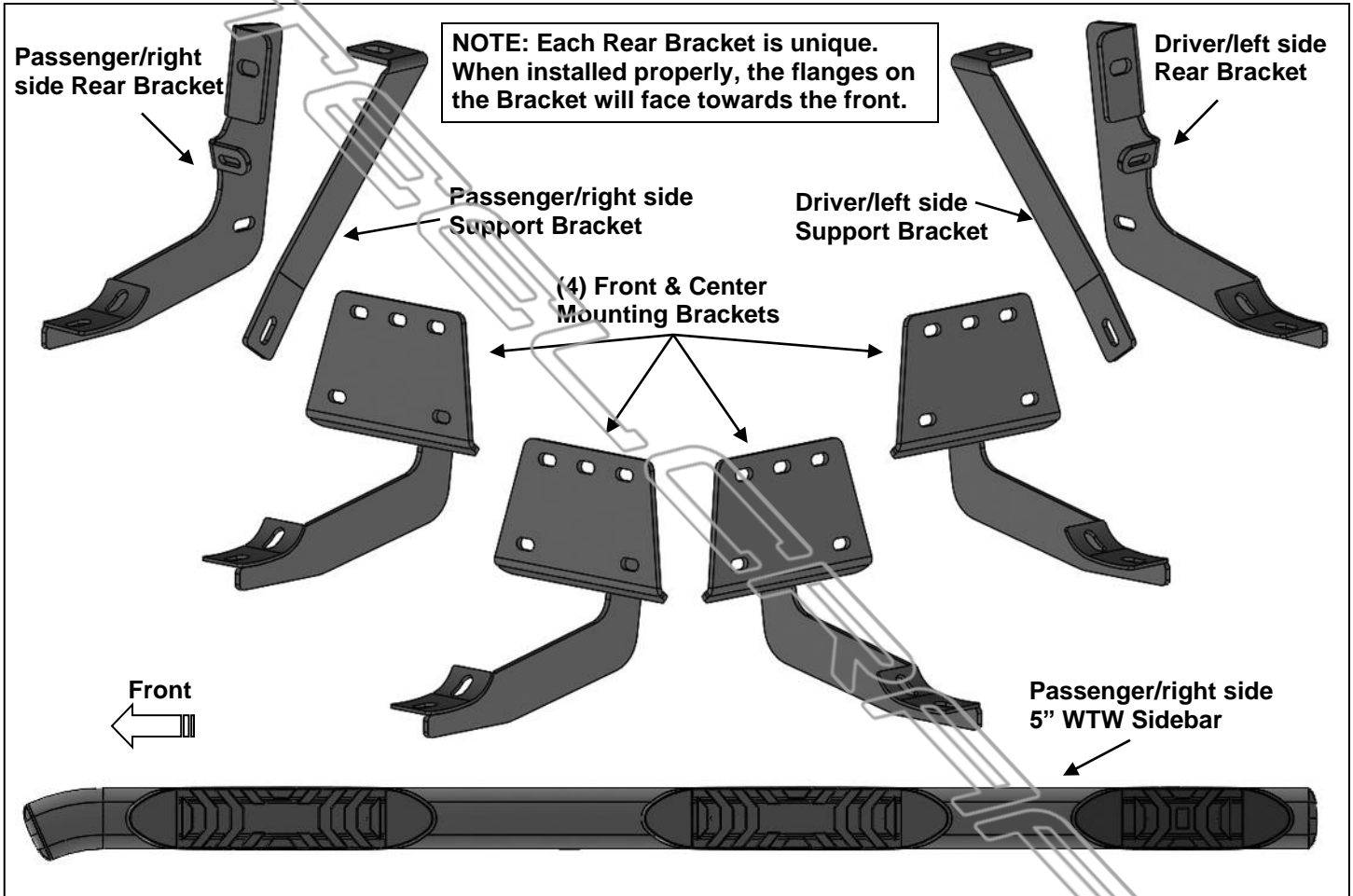

PROCEDURE:

REMOVE CONTENTS FROM BOX. VERIFY ALL PARTS ARE PRESENT. READ INSTRUCTIONS CAREFULLY BEFORE STARTING INSTALLATION. ASSISTANCE IS RECOMMENDED. DRILLING IS REQUIRED.

1. Start the installation under the passenger side of the vehicle. Locate the front (3) factory studs along the inner side of the body panel, **(Figure 1)**. **NOTE:** Use a wire brush or die to remove paint buildup on the threaded studs.
2. Select (1) Front & Center Bracket. **NOTE:** There are (4) Front & Center Brackets that will fit left or right side. Attach the Mounting Bracket to the (3) factory studs with (3) 8mm Flat Washers and (3) 8mm Nylon Lock Nuts, **(Figures 2 & 3)**. Leave brackets loose at this time.
3. Move to the center mounting location, **(Figure 4)**. Repeat **Steps 1 & 2** to install (1) Front/Center Bracket in the center mounting location, **(Figure 5)**.

5" WTW SIDEBARS
2019 DODGE RAM 1500 CREW CAB

4. Move to the end of the cab and locate mounting slot, **(Figure 6)**. Remove the sealing tape from the mounting slot on the body panel.
5. Select (1) 10mm Bolt Plate and (1) 10mm Plastic Retainer, **(Figure 7)**. Partially thread the Plastic Retainer onto the Bolt Plate. Insert the Bolt Plate with Retainer into the rear mounting slot, **(Figure 8)**. **NOTE:** The Plastic Retainer is used to help prevent the Bolt Plate from falling inside the body panel and to aid in Bracket installation.
6. Next, select the Passenger/right side Rear Bracket, **(Figure 9)**. **NOTE:** Each Rear Bracket is unique. When installed properly, the Rear Bracket flanges will face towards the front, **(Figure 9)**. Attach the Bracket to the Bolt Plate using (1) 10mm Flat Washer, (1) 10mm Lock Washer and (1) 10mm Hex Nut, **(Figure 9)**. Do not tighten hardware.
7. Select the Passenger/right side Support Bracket. Use the illustration above and **Figure 10** to help determine the correct Bracket.
8. Remove the rear body bolt from the body mount, **(Figure 11)**. Reuse the factory bolt to attach the top end of the Support Bracket to the body mount. Attach the bottom end of the Support Bracket to the front side of the Rear Bracket with (1) 8mm Hex Bolt, (2) 8mm Flat Washers and (1) 8mm Nylon Lock Nut, **(Figure 12)**. Do not tighten hardware.
9. Carefully unwrap and select the Passenger/right Sidebar. Use the illustration above to help identify the correct Sidebar. Place the Sidebar on top of the Brackets. **IMPORTANT:** Do not slide, (front to back or rotate), the Sidebar on the Brackets or damage to the finish on the Sidebar may result.
10. Attach the Sidebar to the Brackets with (6) 8mm Combo Hex Bolts, **(Figures 13—16)**. Do not tighten hardware at this time.
11. Level the Sidebar to the vehicle. Make sure all (3) Brackets are tight against the bottom of the body panel and tighten all mounting hardware.
12. Mark drilling location onto the pinch weld, **(Figure 17)**.
13. Temporarily remove the Rear Bracket. Drill (1) 1/4" hole through the pinch weld. **IMPORTANT:** Do not drill too close to the bottom edge of the pinch weld.
14. Repeat **Steps 6 & 8** to attach Rear Bracket to Bolt Plate and Support Bracket.
15. Use (1) 6mm Hex Bolt, (2) 6mm Flat Washers and (1) 6mm Nylon Lock Nut to attach the Bracket to the pinch weld, **(Figure 18)**. **NOTE:** Insert the Bolt from outside the pinch weld and out through the Bracket.
16. Check for level then fully tighten all hardware.
17. Repeat **Steps 1—16** for Driver/left Sidebar installation.
18. Do periodic inspections to the installation to make sure that all hardware is secure and tight.

To protect your investment, wax this product after installing. Regular waxing is recommended to add a protective layer over the finish. Do not use any type of polish or wax that may contain abrasives that could damage the finish. Mild soap may be used also to clean the Sidebar.

Passenger/right Side Installation Pictured

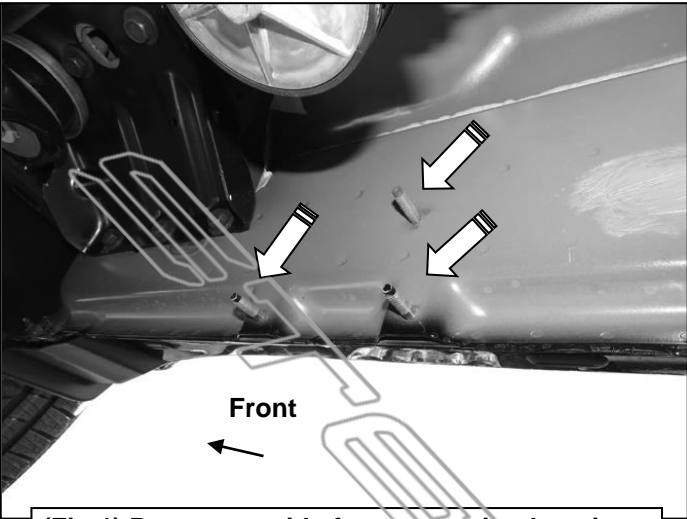

(Fig 1) Passenger side front mounting location

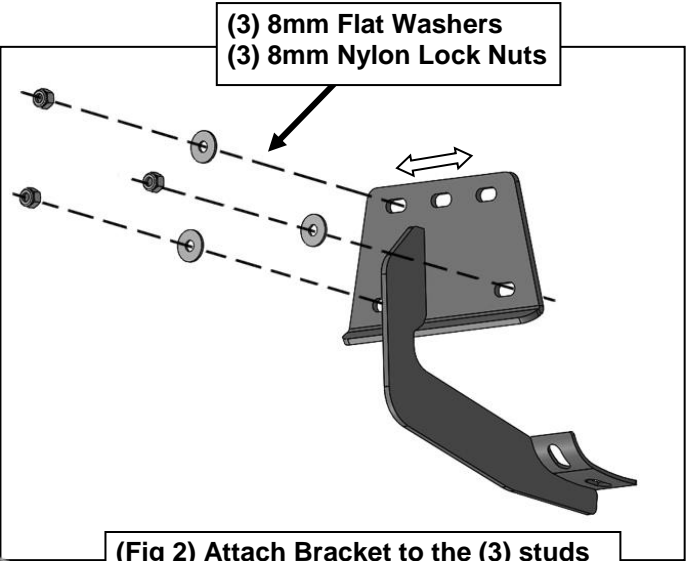

(Fig 2) Attach Bracket to the (3) studs

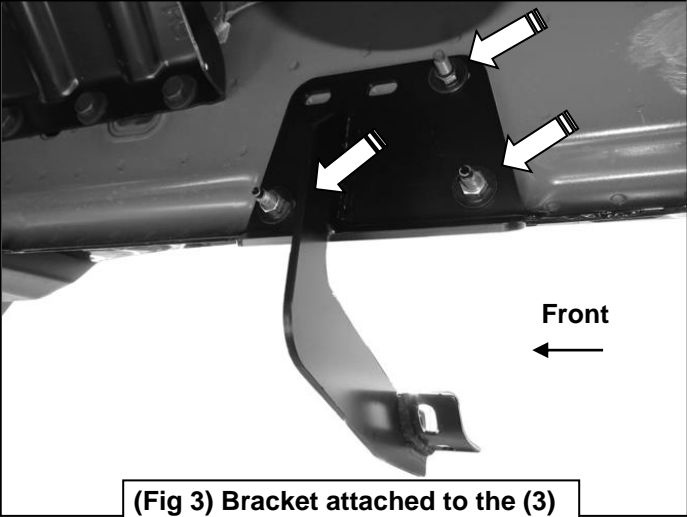

(Fig 3) Bracket attached to the (3) front studs on the passenger side

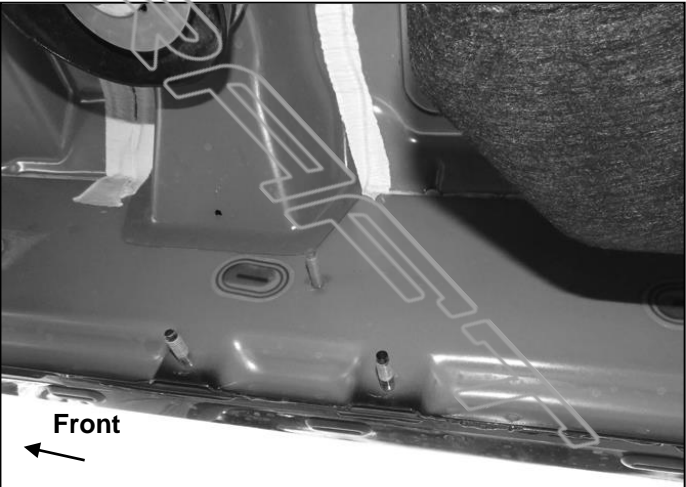

(Fig 4) Passenger side center mounting location

Passenger/right Side Installation Pictured

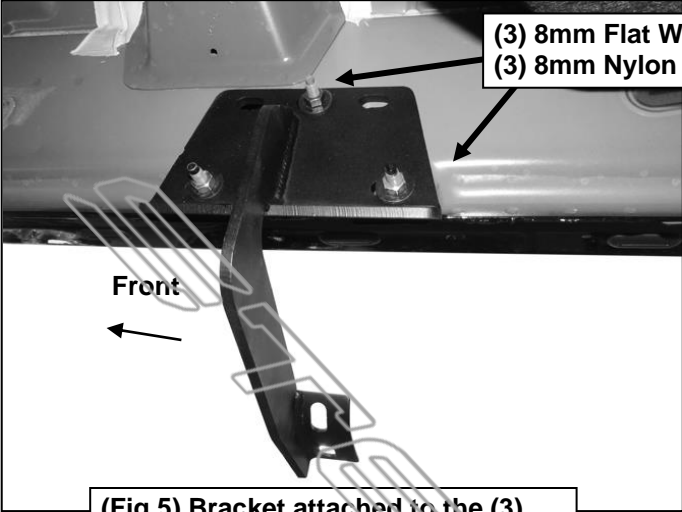

(Fig 5) Bracket attached to the (3) center studs on the passenger side

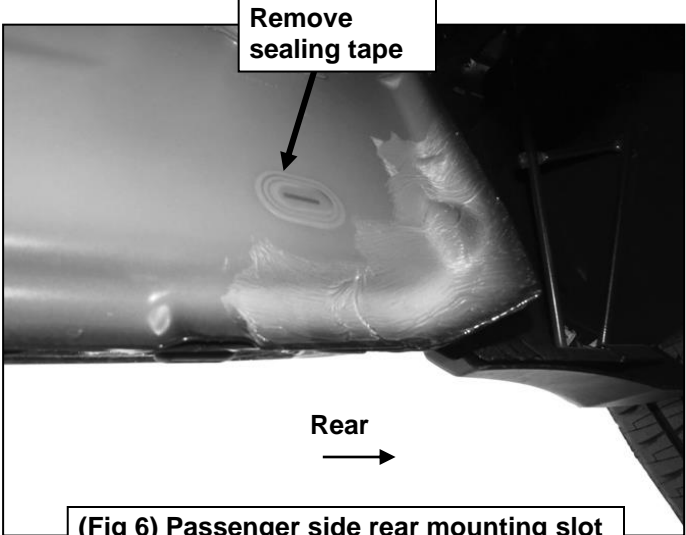

(Fig 6) Passenger side rear mounting slot

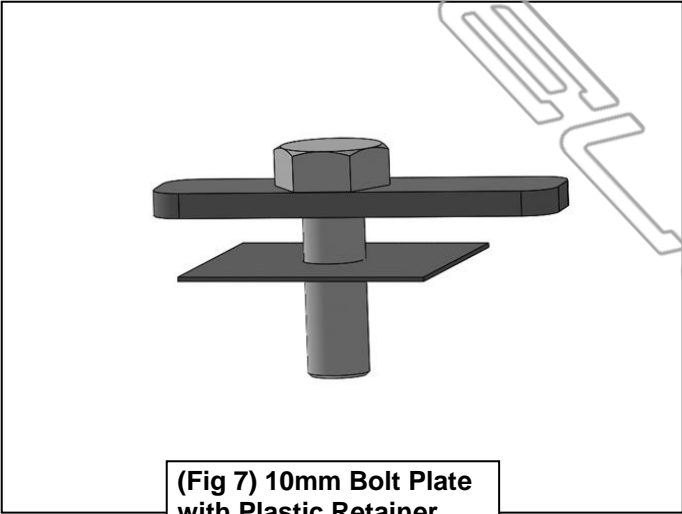

(Fig 7) 10mm Bolt Plate with Plastic Retainer

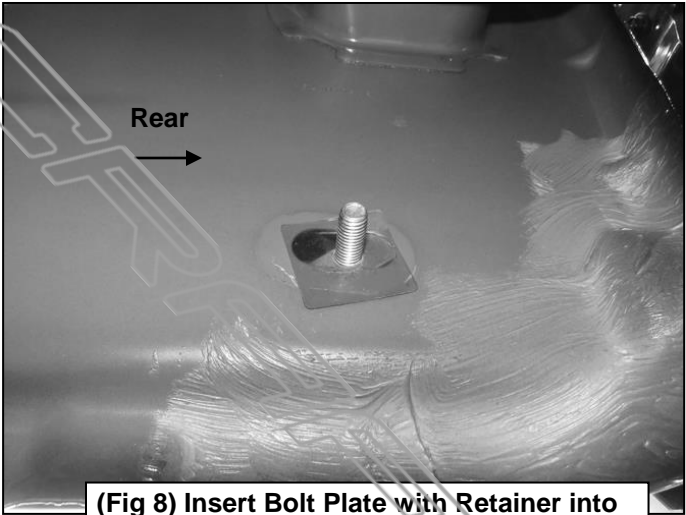

(Fig 8) Insert Bolt Plate with Retainer into the rear slot on the body panel. Plastic Retainer is used to help prevent the Bolt Plate from falling inside the body panel.

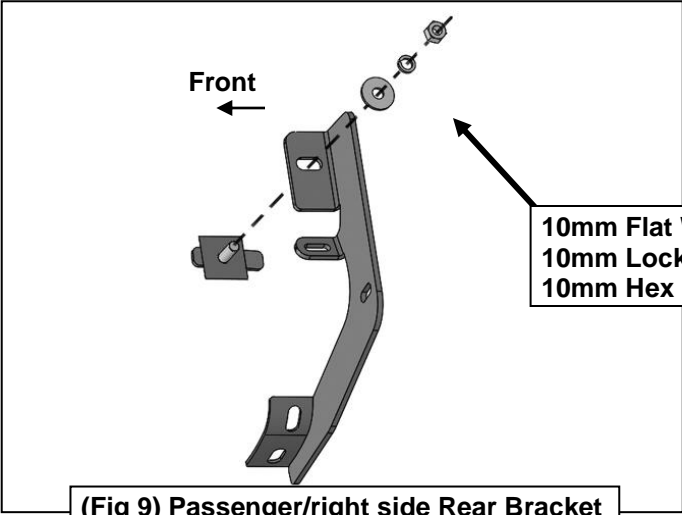

(Fig 9) Passenger/right side Rear Bracket

NOTE: Each Rear Bracket is unique. When installed properly, the flanges on the Bracket will face towards the front.

Passenger/right Side Installation Pictured

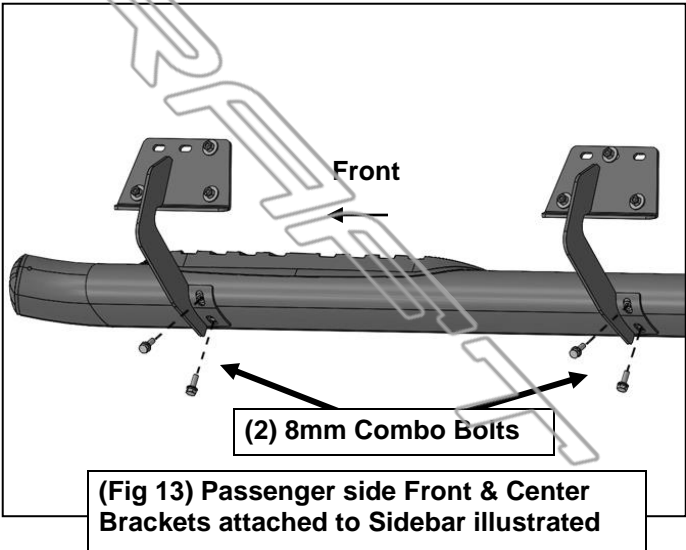
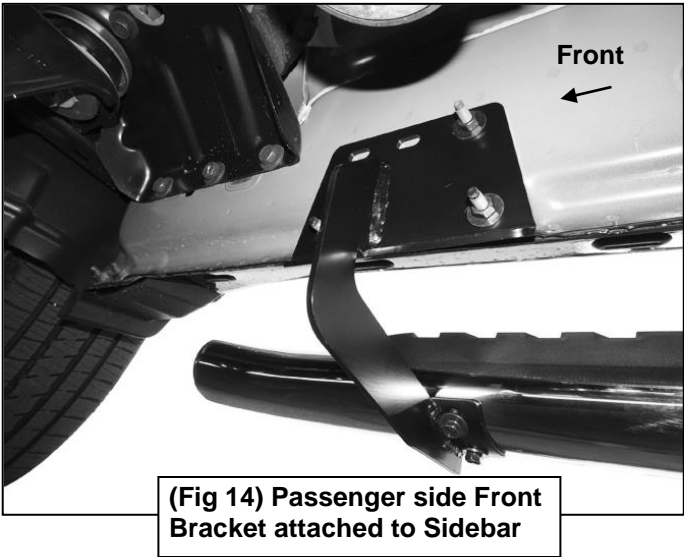
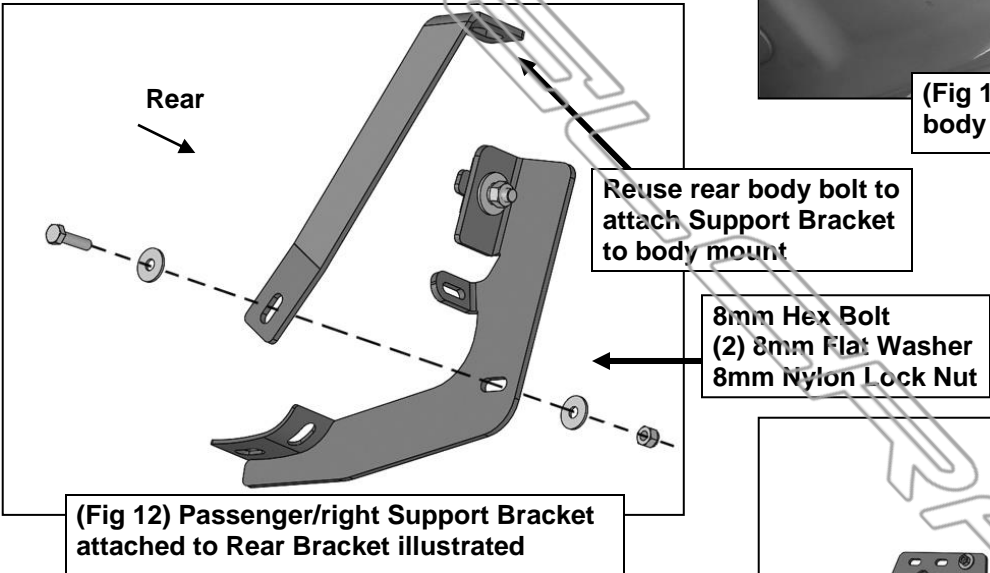
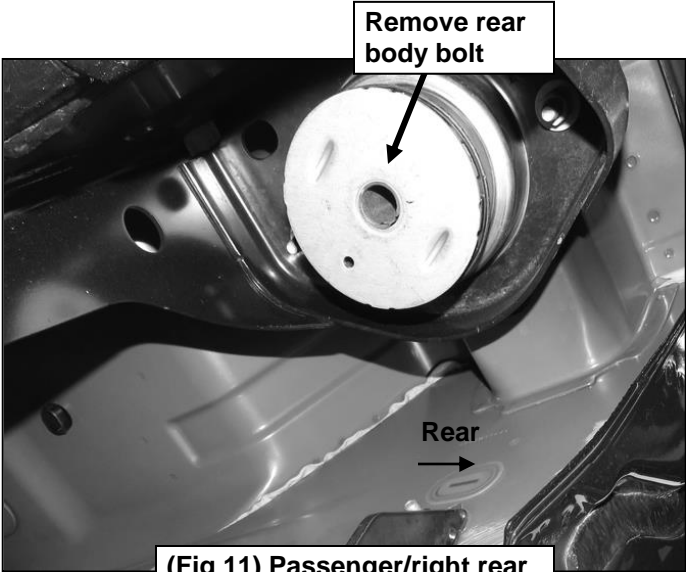
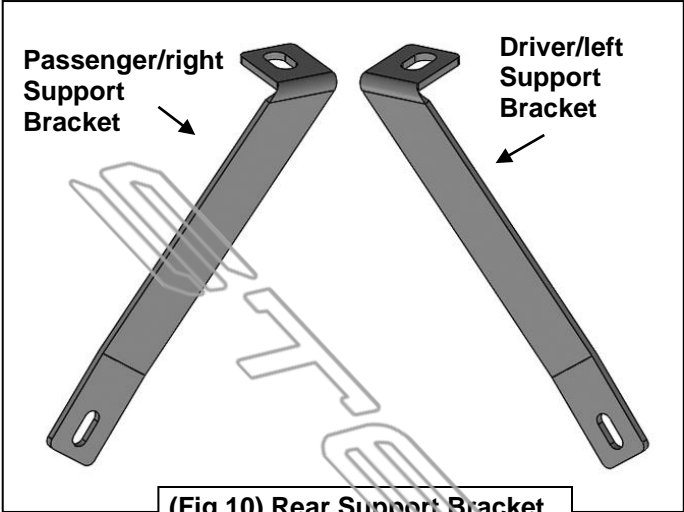

Passenger/right Side Installation Pictured

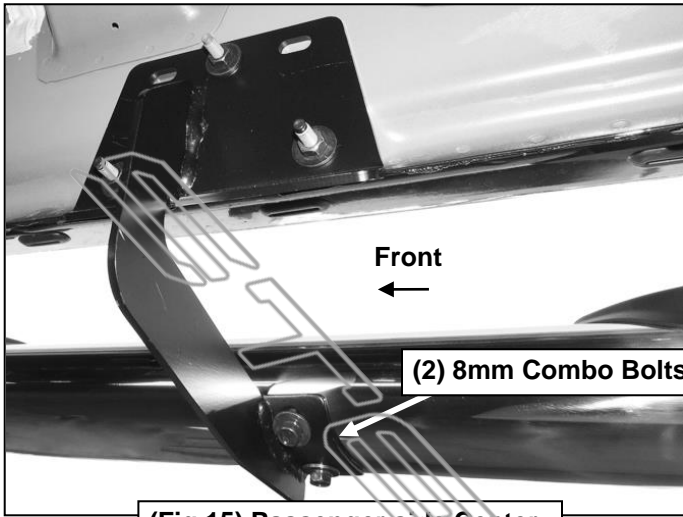

(Fig 15) Passenger side Center Bracket attached to Sidebar

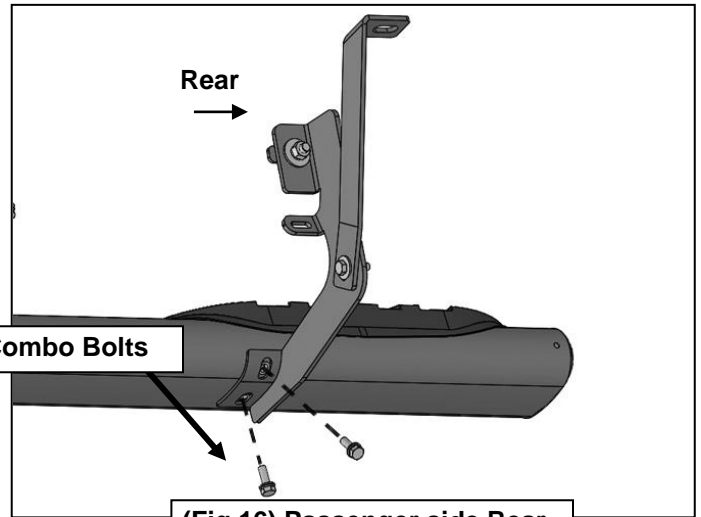

(Fig 16) Passenger side Rear Bracket attached to Sidebar

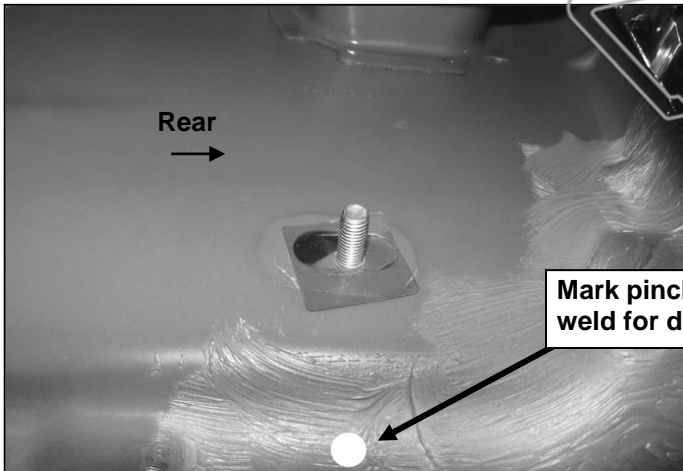

(Fig 17) Drill (1) 1/4" hole through the pinch weld to attach the Rear Bracket to the pinch weld

IMPORTANT: Drilling is required. Drill 1/4" hole through pinch weld to attach the bracket. Complete installation of Sidebar first and level Sidebar before drilling hole for bracket.

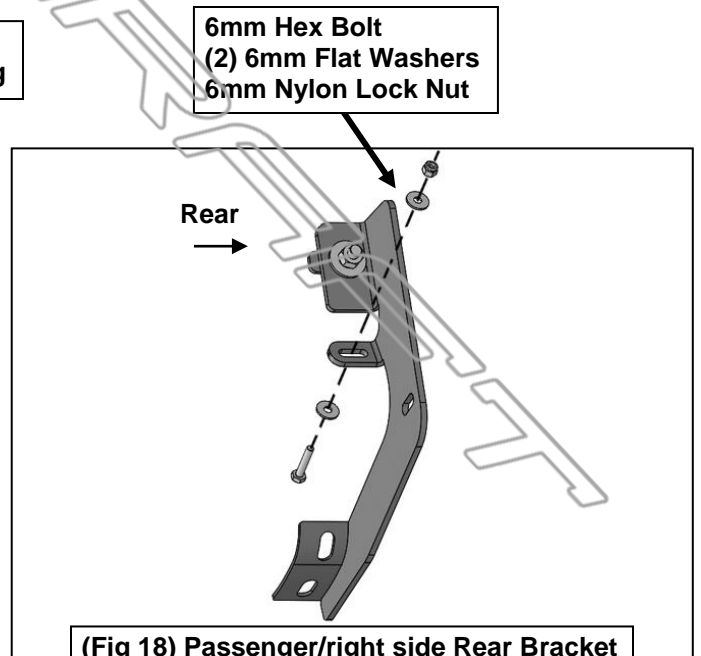

(Fig 18) Passenger/right side Rear Bracket attached to the pinch weld illustrated