

**ELEVATION FRONT BUMPER  
2018+ POLARIS RANGER 1000/XP 1000**

**PARTS LIST:**

1	Elevation Front Bumper	6	10mm Lock Washers
1	Skid Plate	4	10mm Hex Nuts
1	Winch Plate	4	8mm x 25mm Hex Bolts
1	Driver/Left L-Bracket	3	8mm x 25mm Carriage Bolts
1	Passenger/Right L-Bracket	2	8mm x 16mm Hex Bolts
2	10mm x 65mm Hex Bolts	13	8mm x 24mm OD x 2mm Flat Washers
2	10mm x 35mm Carriage Bolts	9	8mm Lock Washers
2	10mm x 25mm Hex Bolts	7	8mm Hex Nuts
8	10mm x 30mm OD x 2.5mm Flat Washers		

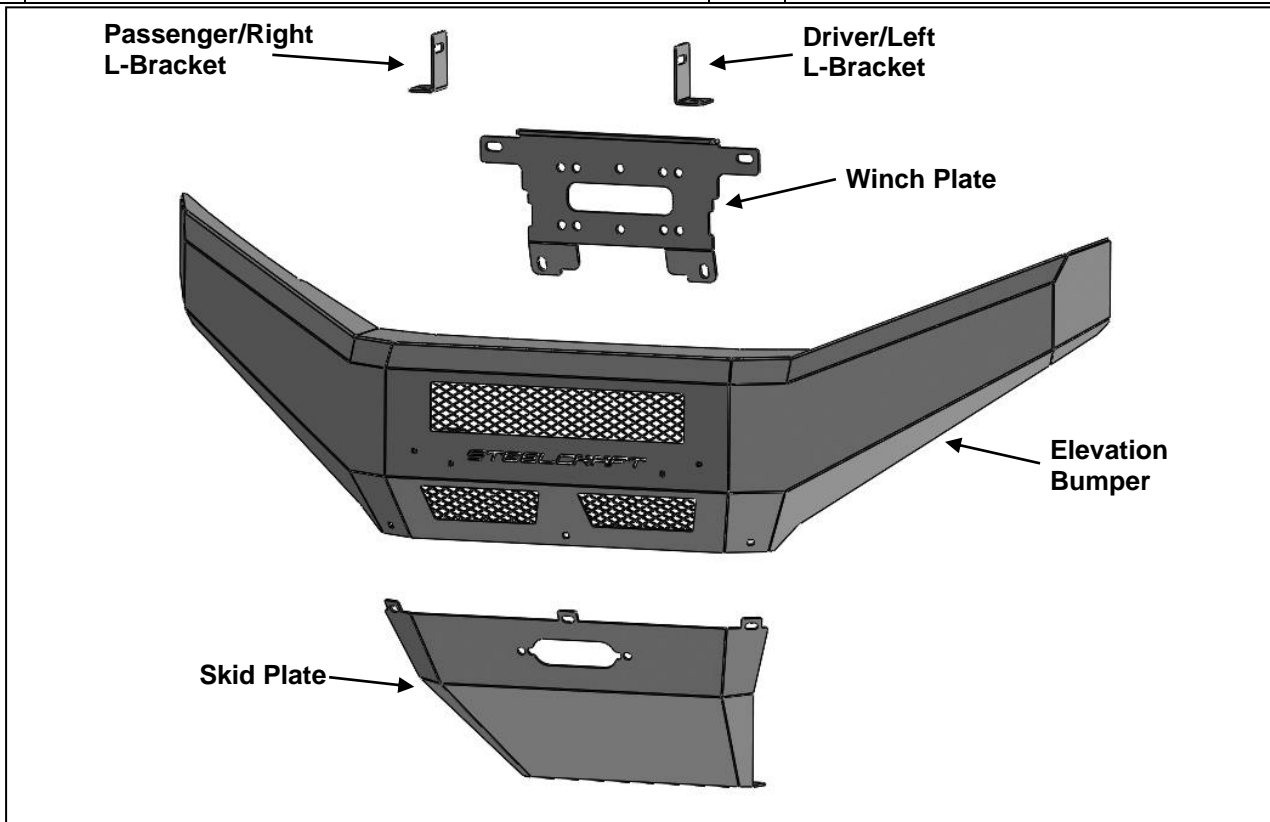

**PROCEDURE:**

**REMOVE CONTENTS FROM BOX. VERIFY ALL PARTS ARE PRESENT. READ INSTRUCTIONS CAREFULLY BEFORE STARTING INSTALLATION. BUMPER IS HEAVY, ASSISTANCE IS HIGHLY RECOMMENDED TO AVOID POSSIBLE INJURY OR DAMAGE TO THE VEHICLE.**

1. Start at the front of the vehicle. Remove the lower bolts from the bottom of the factory skid plate and upper bolts on the sides of the factory bumper, **(Figures 1 & 2)**. Move the factory bumper and skid plate to a smooth flat surface. If necessary, remove the lower grille.
2. **Determine if a 14-inch Light Bar will be attached, (Light not included)**
  - a. Select the Driver/Left L-Bracket.
  - b. Attach the L-Bracket to the back of the Elevation Front Bumper with (1) 8mm x 25mm Hex Bolt, (2) 8mm Flat Washers, (1) 8mm Lock Washer and (1) 8mm Hex Nut, **(Figure 3)**.
  - c. Repeat **Steps 2a & 2b** to attach the Passenger/Right L-Bracket to the Bumper.
  - d. Select the Light Bar, (Light not included).
  - e. Attach the Light Bar to the L-Brackets with (2) 8mm x 16mm Hex Bolts, (2) 8mm Lock Washers and (2) 8mm Flat Washers, **(Figure 3)**.
3. **Determine if a Winch will be attached (Winch not included)**
  - a. Select the Winch Plate.
  - b. Attach a Winch to the Plate, (Winch not included). Follow Winch manufacturer's instructions.

**ELEVATION FRONT BUMPER  
2018+ POLARIS RANGER 1000/XP 1000**

- c. Locate the Winch Plate mounting location, **(Figure 4)**.
  - d. Attach the top of the Plate to the vehicle with (2) 10mm x 25mm Hex Bolts, (2) 10mm Lock Washers and (2) 10mm Flat Washers, **(Figure 5)**. Do not tighten hardware.
  - e. Attach the bottom of the Winch Plate to the vehicle with (2) 10mm x 35mm Carriage Bolts, (2) 10mm Flat Washers, (2) 10mm Lock Washers and (2) 10mm Hex Nuts, **(Figure 5)**.
  - f. Level and adjust the Winch Plate and tighten hardware.
4. Select the Elevation Front Bumper and the Skid Plate. Attach the Skid Plate to the Bumper with (3) 8mm x 25mm Carriage Bolts, (3) 8mm Flat Washers, (3) 8mm Lock Washers and (3) 8mm Hex Nuts, **(Figure 6)**. Do not tighten hardware.
  5. Reattach the OE lower grille if removed. Attach the Bumper to the front of the vehicle with (2) 10mm x 65mm Hex Bolts, (4) 10mm Flat Washers, (2) 10mm Lock Washers and (2) 10mm Hex Nuts, **(Figures 7 & 8)**. Do not tighten hardware.
  6. Attach the Skid Plate to the bottom of the vehicle with (2) 8m x 25mm Hex Bolts, (4) 8mm Flat Washers, (2) 8mm Lock Washers and (2) 8mm Hex Nuts, **(Figures 9 & 10)**. Do not tighten hardware.
  7. Level and adjust the bumper and tighten all hardware.
  8. Do periodic inspections to the installation to make sure that all hardware is secure and tight.

**To protect your investment**, Do not use any type of polish or wax that may contain abrasives that could damage the finish. Mild soap may be used to clean the Front Bumper assembly.

**Driver/Left Side Installation Pictured**

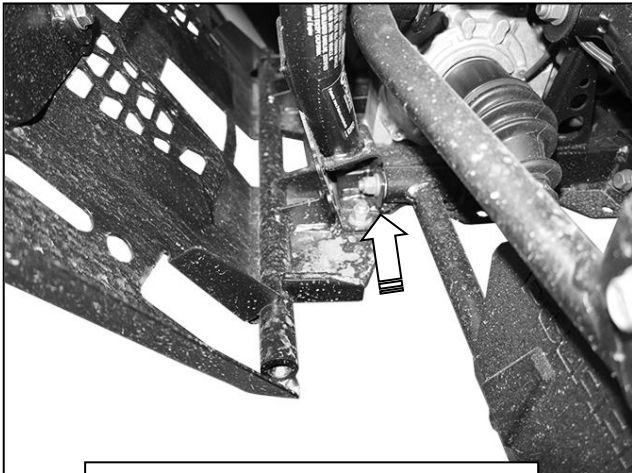

**(Fig 1) Remove the lower factory bolts attaching the bumper to the vehicle, (Driver/Left Shown)**

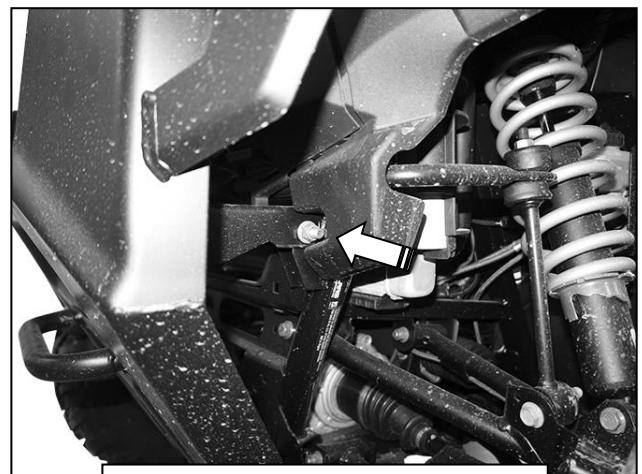

**(Fig 2) Remove the upper factory bolts attaching the bumper to the vehicle, (Driver/Left Shown)**

**ELEVATION FRONT BUMPER  
2018+ POLARIS RANGER 1000/XP 1000**

**Driver/Left Side Installation Pictured**

- 8mm x 16mm Hex Bolt
- 8mm Lock Washer
- 8mm Flat Washer

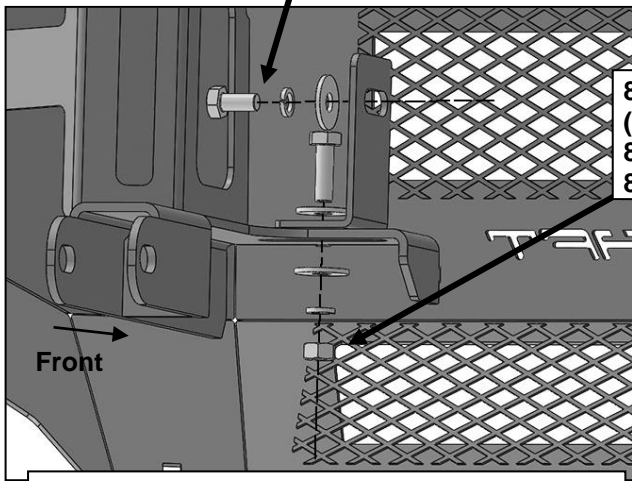

- 8mm x 25mm Hex Bolt
- (2) 8mm Flat Washers
- 8mm Lock Washer
- 8mm Hex Nut

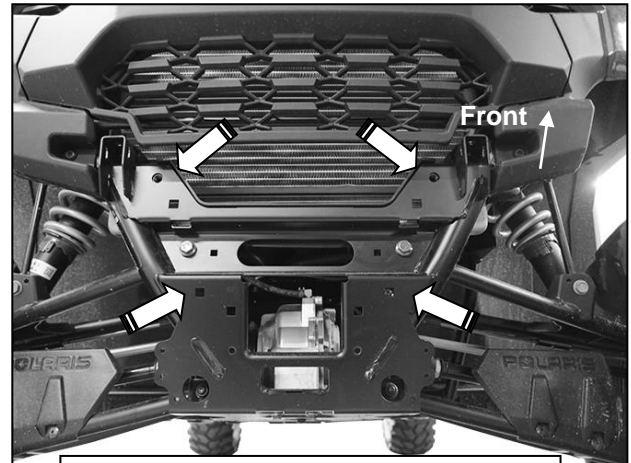

**(Fig 3) Attach the Driver/Left L-Bracket to the back of the Bumper. Attach a 14-inch Light Bar (Light not included) to the L-Brackets.**

**(Fig 4) Winch Plate mounting location**

- (2) 10mm x 25mm Hex Bolts
- (2) 10mm Lock Washers
- (2) 10mm Flat Washers

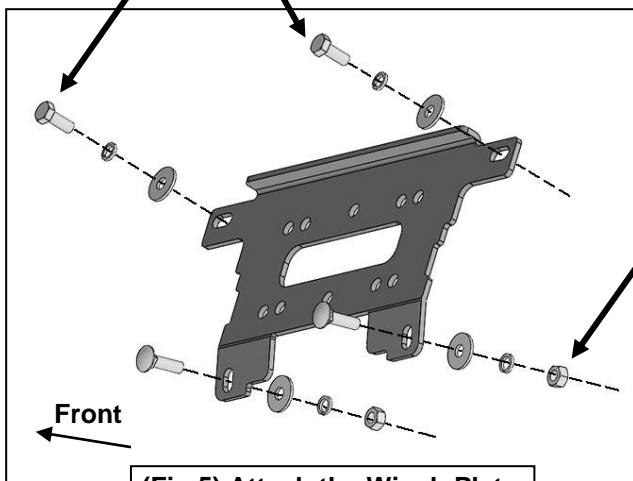

- (2) 10mm x 35mm Carriage Bolts
- (2) 10mm Flat Washers
- (2) 10mm Lock Washers
- (2) 10mm Hex Nuts

**(Fig 5) Attach the Winch Plate to the front of the vehicle**

- (3) 8mm x 25mm Carriage Bolts
- (3) 8mm Flat Washers
- (3) 8mm Lock Washers
- (3) 8mm Hex Nuts

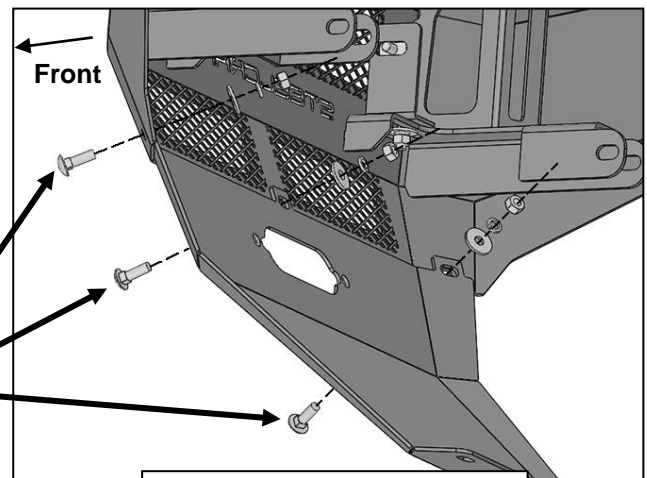

**(Fig 6) Attach the Skid Plate to the bottom of the Bumper**

ELEVATION FRONT BUMPER  
2018+ POLARIS RANGER 1000/XP 1000

Driver/Left Side Installation Pictured



(Fig 7) Driver/Left upper mounting location

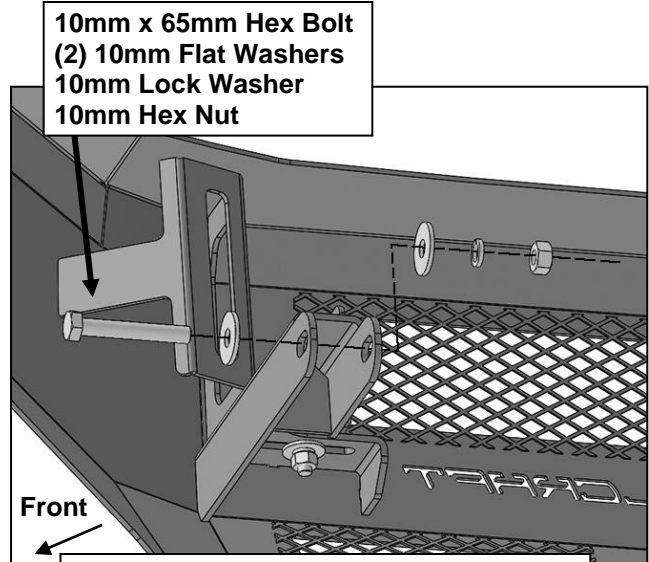

(Fig 8) Attach the Bumper to the upper mounting locations, (Driver/Left shown)

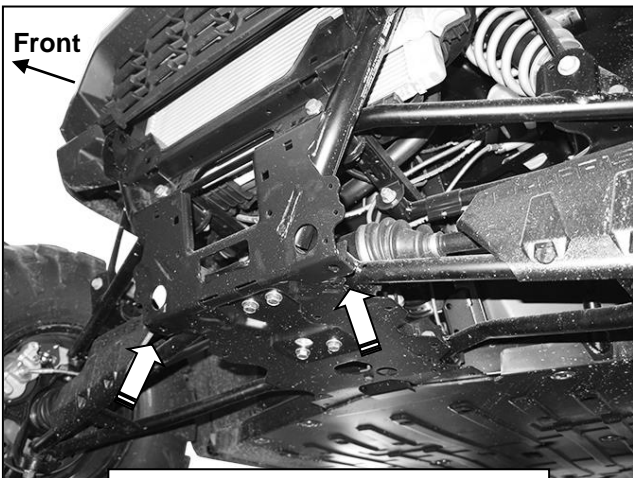

(Fig 9) Lower mounting locations

**WARNING!** Do not crawl under bumper unless the bumper is properly supported on blocks or stands or the bumper may fall.

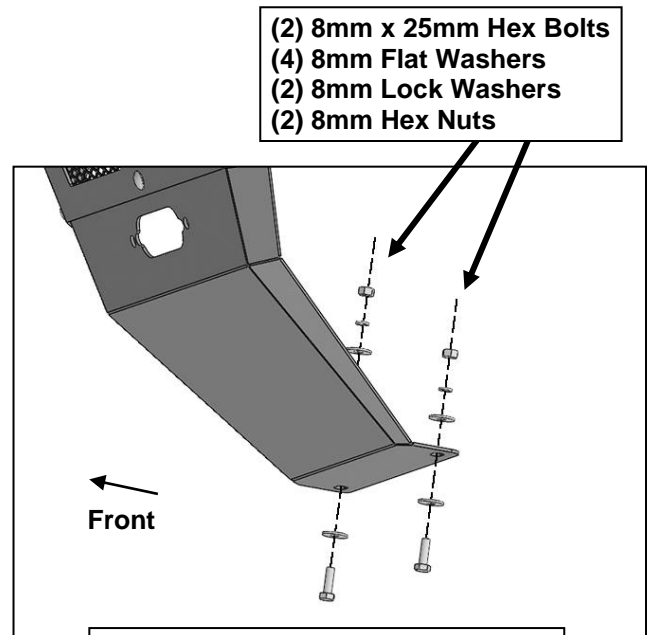

(Fig 10) Attach Driver/Left Mounting Bracket to the front of the frame