

**HD REPLACEMENT FRONT BUMPER
2020—23 GMC SIERRA 25-3500**

PARTS LIST:

1	HD Replacement Front Bumper	4	12-1.75mm x 130mm Hex Bolts
1	Driver/left Mounting Bracket	18	12-1.75mm x 50mm Hex Bolts
1	Passenger/right Mounting Bracket	44	12mm x 32mm x 3mm Flat Washers
2	Tow Hook Side Shims - Thick	22	12mm Lock Washers
2	Tow hook Side Shims - Thin	22	12mm Hex Nuts
2	Left Facing Support Bracket	2	8-1.25mm x 30mm Hex Bolts
2	Right Facing Support Bracket	4	8mm x 28mm x 3mm Flat Washers
2	Shutter Relocation "L" Brackets	2	8mm Nylon Lock Nuts
4	Sensor Plugs	10	6-1.0mm x 20mm Hex Bolts
4	Sealing Washers	20	6mm x 18mm x 1.6mm Flat Washers
4	20mm x 10mm Foam Spacers	10	6mm Nylon Lock Nuts
4	Retaining Caps	8	4mm Self Tapping Screws
2	Sensor Wiring Harness Extensions	1	4mm Wrench
2	Plastic Plugs for License Plate	1	Sensor Covers Kit

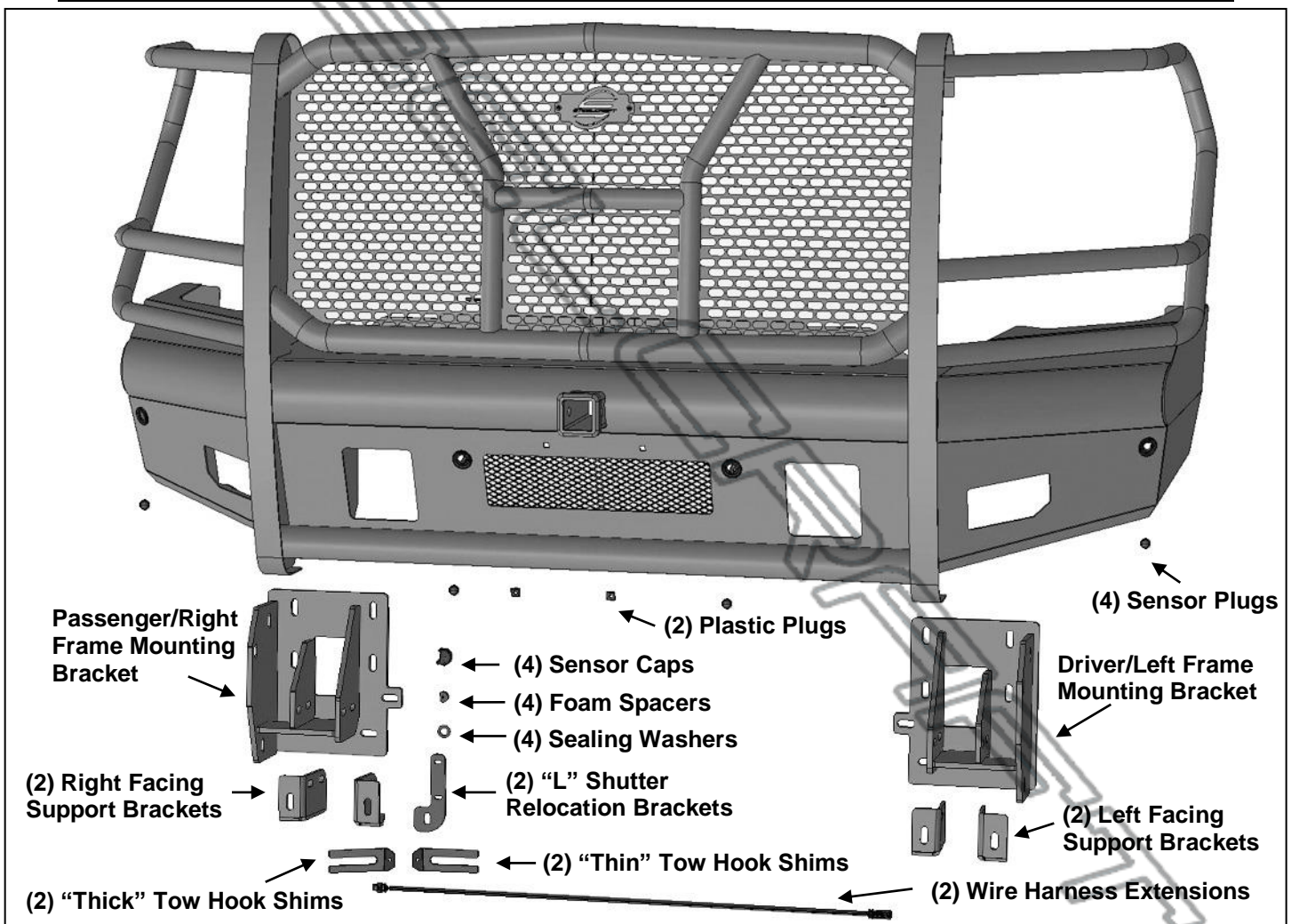

PROCEDURE:

REMOVE CONTENTS FROM BOX. VERIFY ALL PARTS ARE PRESENT. READ INSTRUCTIONS CAREFULLY BEFORE STARTING INSTALLATION. BUMPER IS HEAVY, ASSISTANCE IS HIGHLY RECOMMENDED TO AVOID POSSIBLE INJURY OR DAMAGE TO THE VEHICLE.

1. Start installation at the driver/left side of the front grille. Carefully pull the end of the body panel, (fascia), closest to the grille, outward to release it from the clips, (**Figure 1**). Only release the forward

HD REPLACEMENT FRONT BUMPER 2020—23 GMC SIERRA 25-3500

end of the fascia, it is not necessary to remove it. Repeat this **Step** to release the passenger/right end of the fascia body panel.

2. Open the hood and remove the hood release handle and the plastic cover from the top of the radiator and the grille, **(Figure 2)**. Remove the hardware attaching the grille and pull it straight out from the vehicle. On models with grille mounted camera, unplug harness leading to the camera and remove the grille, **(Figure 3)**. Temporarily reattach the hood release handle.
3. Unplug any wiring harnesses leading to the front bumper. Remove the license plate and bracket if equipped, **(Figure 3)**. Move all harnesses away from bumper.
4. Remove the hardware at each end of the bumper attaching the bumper supports to each side of the frame, **(Figure 4)**.
5. Place blocks or jack stands under the front bumper to support it during mounting bolt removal. Once the bumper has been safely supported, from above the bumper, remove the (2) factory upper and lower bumper bolts from each side, **(Figure 5)**. **WARNING!** Assistance is required to hold the bumper in place during bolt removal to prevent the bumper from falling. Remove the bumper assembly. Move the bumper to a clean surface
6. Remove the factory bumper brackets and tow hooks, (if equipped), from the end of frame, **(Figure 6 & 7)**. On models with lower radiator shutter assembly, unplug and remove the assembly.
7. Select (1) Left Facing Lower Support Bracket, **(Figure 8)**. Attach the Left Facing Support Bracket to the outer side of the frame with the included (2) 12mm x 50mm Hex Bolts, (4) 12mm Flat Washers, (2) 12mm Lock Washers and (2) 12mm Hex Nuts. Do not fully tighten hardware at this time. Repeat this **Step** to attach (1) Right Facing Support Bracket to the inner side of the frame.
8. Select the driver/left Frame Mounting Bracket, **(Figure 9)**. Reuse the factory hex bolts to attach the Bracket to the mounting plate on the end of the frame. Do not tighten hardware at this time.
9. Attach the bottom of the Frame Bracket to the front of the Support Brackets with (2) 12mm x 50mm Hex Bolt, (4) 12mm Flat Washers, (2) 12mm Lock Washers and (2) 12mm Hex Nuts, **(Figures 10 & 11)**. Do not fully tighten at this time.
10. Repeat **Steps 7—9** to install the passenger/right Frame and Support Brackets.
11. On models equipped with lower radiator shutter system, remove shutter assembly from outer plastic housing, **(Figure 12)**. Select (1) “L” Relocation Bracket. Attach the “L” Bracket to the front of the Frame Mounting Bracket with the included (1) 8mm x 30mm Hex Bolt, (2) 8mm Flat Washers and (1) 8mm Nylon Lock Nut. Repeat this Step to attach the remaining “L” Bracket, **(Figure 13)**.
12. Attach the shutter assembly to the front of the “L” Brackets with the included (4) 6mm x 20mm Hex Bolts, (8) 6mm Flat Washers and (4) 6mm Nylon Lock Nuts, **(Figures 13 & 14)**. Do not overtighten the 6mm hardware or damage to the shutter assembly may result. **NOTE:** Shutter assembly will be installed upside-down. Plug wiring harness into shutter assembly
13. Select the driver/left tow hook if equipped. Attach the tow hook to the Bracket with the included (2) 12mm x 130mm Hex Bolts, (4) 12mm Flat Washers, (2) 12mm Lock Washers and (2) 12mm Hex Nuts, **(Figure 15)**. Use the included Thick or Thin Shims to adjust the fit between the sides of the tow hook and the inside of the Frame Bracket, **(Figure 16)**. Fully tighten the tow hook hardware. Repeat this Step to install the passenger/right tow hook.
14. Disassemble the front bumper to access and remove the sensors, wiring harness and fog lights as equipped, **(Figure 17)**. Sensors, (if equipped), must be installed in Bumper before installing Bumper Assembly.

Models without bumper sensors:

- a. From the front of the Bumper, push the included Plastic Plugs into the sensor mounting holes, **(Figure 18)**.

Models with bumper mounted sensors:

- a. Select the driver/left outer sensor.
- b. Remove the silicone seal from the end of the sensor. Slide the included larger Sensor Seal over front of sensor, **(Figure 19)**.
- c. Insert sensor with Seal into sensor mount, **(Figure 20)**.
- d. Place Foam Spacer over end of sensor. Push Sensor Retaining Cap onto sensor mount and lock into mounting holes, **(Figure 20)**.
- e. Repeat previous Steps to install remaining sensors.

HD REPLACEMENT FRONT BUMPER 2020—23 GMC SIERRA 25-3500

15. Models with fog lights:

- a. Attach the driver/left fog light to the mounting tabs on the back of the Bumper with the included (3) 6mm x 20mm Hex Bolts, (6) 6mm Flat Washers and (3) 6mm Nylon Lock Nuts, **(Figure 21)**.
NOTE: Rotate fog light 90-degrees for installation. Do not overtighten hardware or damage to the light may result.
- b. Repeat the previous Steps to attach the passenger/right fog light.

16. Install the factory bumper wiring harness for sensors and fog lights as equipped. Run wiring harness through Brackets to reach sensors, **(Figure 22)**. **NOTE:** (2) Wire Harness Extensions have been included to extend the factory harness to reach the sensors as needed.
17. With assistance, position the Bumper Assembly up to and over the Brackets. Temporarily support the weight of the Bumper. **WARNING:** To avoid possible injury or damage to the vehicle, do not proceed until the Bumper is fully and safely supported.
18. Line up the (3) holes in the driver/left side mounting plate on the inside of the Bumper with the (3) slots in the Frame Bracket. Attach the Bumper to the Bracket with the included (3) 12mm x 50mm Hex Bolts, (6) 12mm Flat Washers, (3) 12mm Lock washers and (3) 12mm Hex Nuts, **(Figures 23 & 24)**. Do not fully tighten hardware at this time. Repeat this Step to attach the passenger/right side of the Bumper.
19. Level and adjust the Bumper and fully tighten all 12mm hardware to 65-70ft-lbs.
20. Use the included (2) push-in Plastic Plugs to attach the front license plate, (if required), to the (2) holes in the front Bumper, **(Figure 25)**.
21. Models with grille mounted camera, remove screen from center of Bumper, **(Figure 25)**.
22. Do periodic inspections to the installation to make sure that all hardware is secure and tight.

To protect your investment, Do not use any type of polish or wax that may contain abrasives that could damage the finish. Mild soap may be used to clean the Front Bumper assembly.

Driver/left Side Installation Pictured



(Fig 1) Pull end of plastic panel (fascia) out and away from grille. Do not remove panel, only release the end of panel covering grille



(Fig 2) Remove hood release handle and cover. Reinstall handle. Carefully remove grille. Models equipped with grille mounted camera, pull grille forward and unplug camera

**HD REPLACEMENT FRONT BUMPER
2020—23 GMC SIERRA 25-3500**

Driver/left Side Installation Pictured



(Fig 3) Reattach hood release lever. Disconnect wire harnesses leading to bumper

WARNING! Do not crawl under bumper unless it is properly supported on blocks or stands or the bumper may fall.

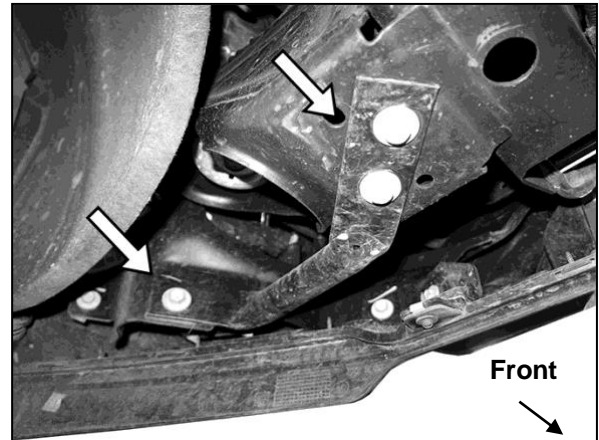

(Fig 4) Remove the outer bumper supports attached to the bottom of the frame

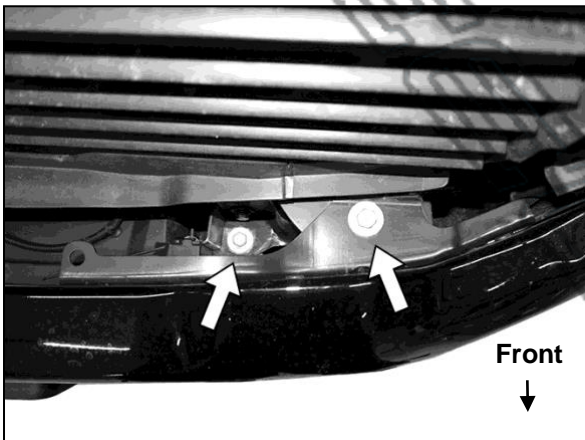

(Fig 5) From above, remove the hex bolts attaching the bumper assembly to the frame bumper brackets (top visible-arrow)

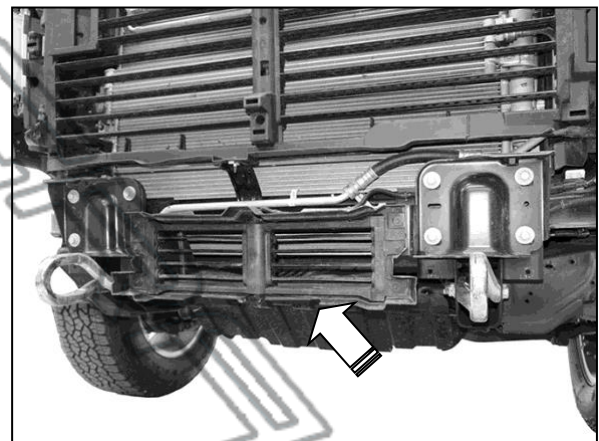

(Fig 6) Remove tow hooks and bumper brackets. Unplug and remove the shutter assembly (arrow) if equipped



(Fig 7) Bumper removed

Driver/left Side Installation Pictured

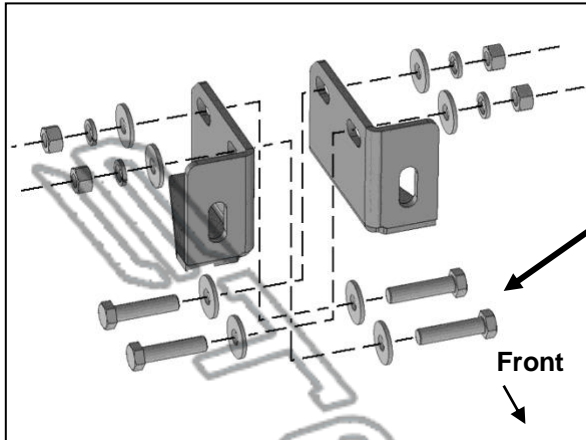

- (4) 12mm x 50mm Hex Bolts
- (8) 12mm Flat Washers
- (4) 12mm Lock Washers
- (4) 12mm Hex Nuts

(Fig 8) Attach (1) Left Facing and (1) Right Facing Support Bracket to the sides of the frame

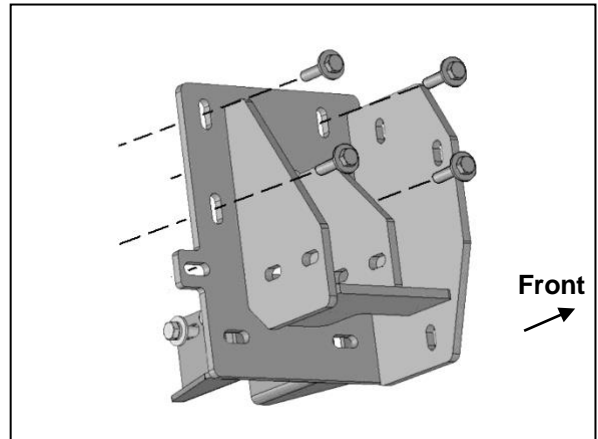

(Fig 9) Reuse the factory hex bolts to attach Driver/left Frame Bracket to end of frame

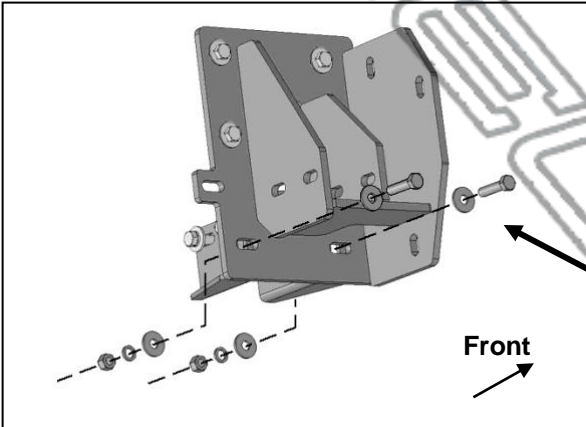

- (2) 12mm x 50mm Hex Bolts
- (4) 12mm Flat Washers
- (2) 12mm Lock Washers
- (2) 12mm Hex Nuts

(Fig 10) Attach the Support Brackets to the bottom slots in the driver/left Frame Bracket

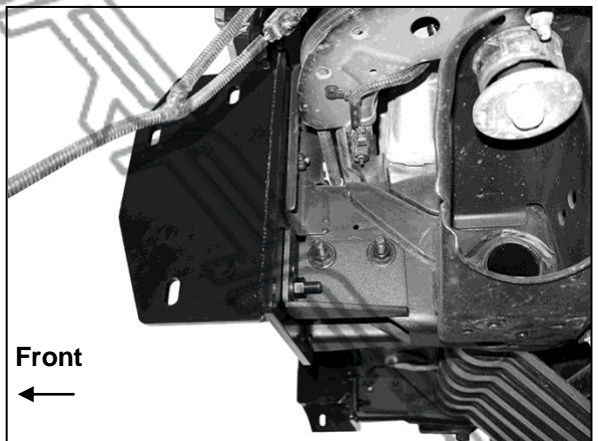

(Fig 11) Left facing Support Bracket installed

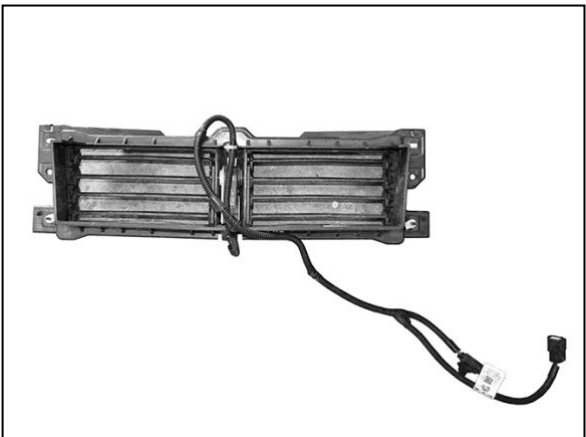

(Fig 12) Remove inner shutter assembly from plastic outer housing (if equipped)

Driver/left Side Installation Pictured

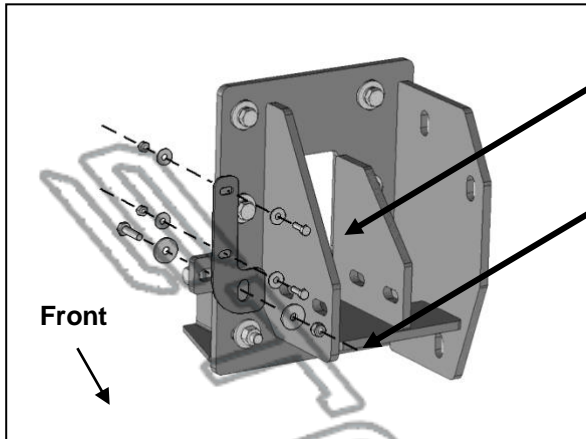

- (2) 6mm x 20mm Hex Bolts
- (4) 6mm Flat Washers
- (2) 6mm Nylon Lock Nuts

- 8mm x 30mm Hex Bolt
- (2) 8mm Flat Washers
- 8mm Nylon Lock Nut

(Fig 13) Attach "L" Relocation Brackets to front of Frame Brackets. Attach shutter assembly to front of Relocation Brackets

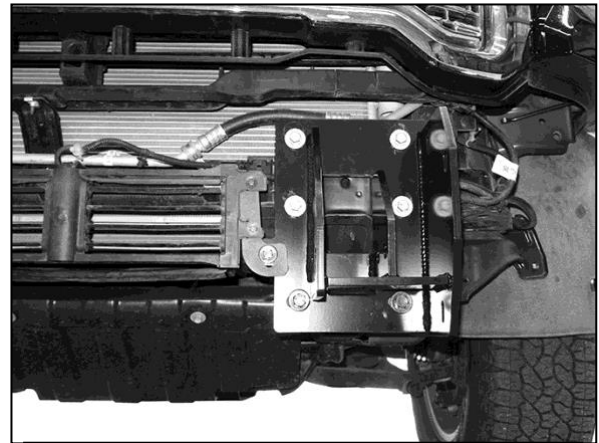

(Fig 14) Attach shutter assembly, (if equipped), to front of Relocation Brackets

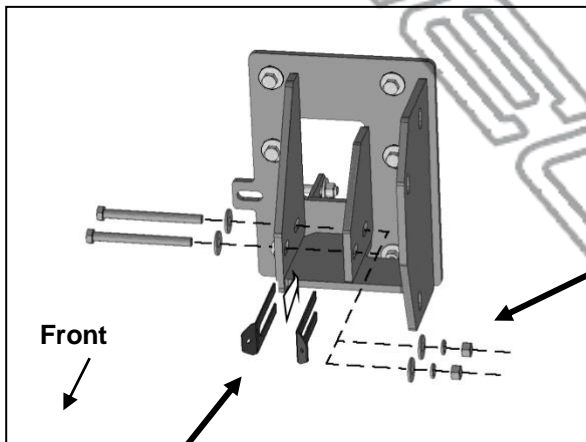

- (2) 12mm x 130mm Hex Bolts
- (4) 12mm Flat Washers
- (2) 12mm Nylon Lock Nuts

(Fig 15) Insert Thick or Thin Shims to adjust fit between tow hook and Bracket

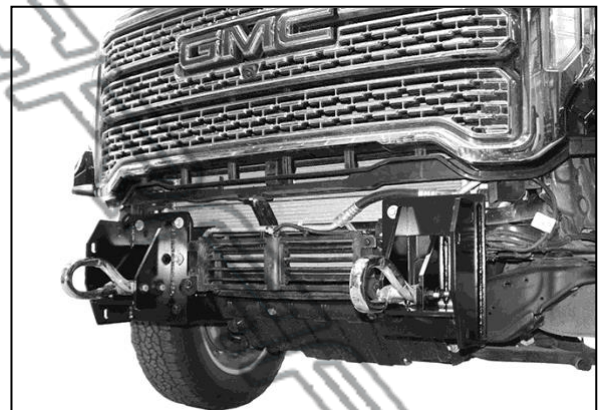

(Fig 16) Frame and Relocation Brackets, shutter assembly and tow hooks installed

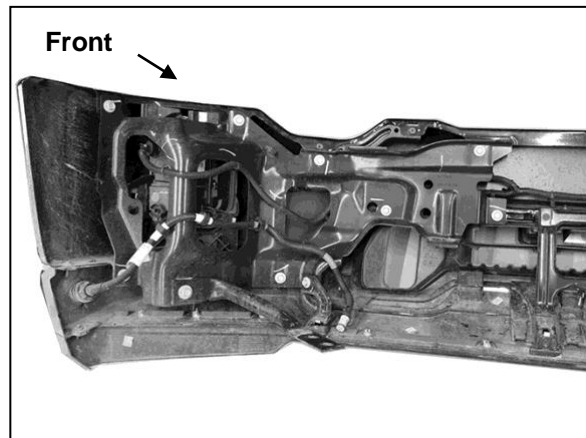

(Fig 17) Disassemble bumper and remove fog lights, sensors and wiring harness as equipped

Driver/left Side Installation Pictured

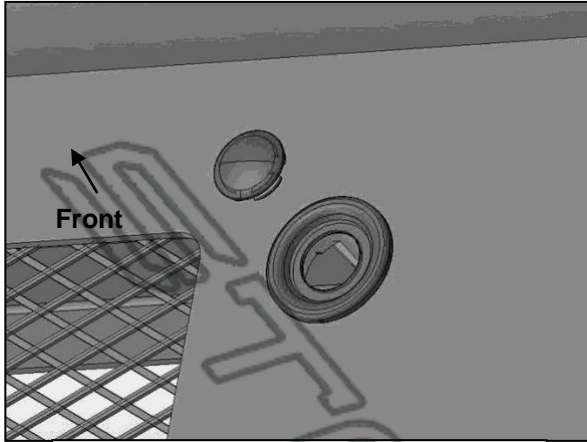

(Fig 18) Push Plug into sensor mount

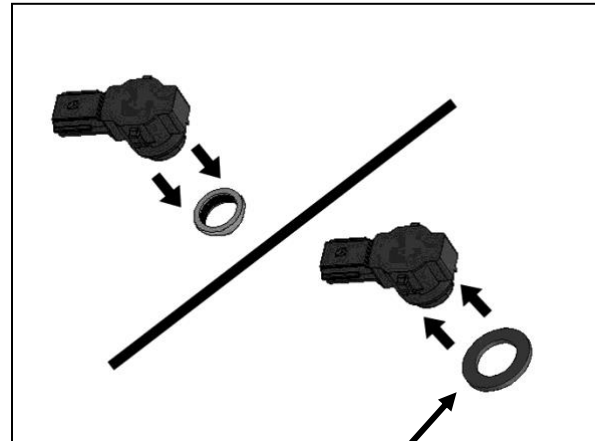

(Fig 19) Remove silicone seal from sensor. Slide large Seal over end of sensor (arrow)

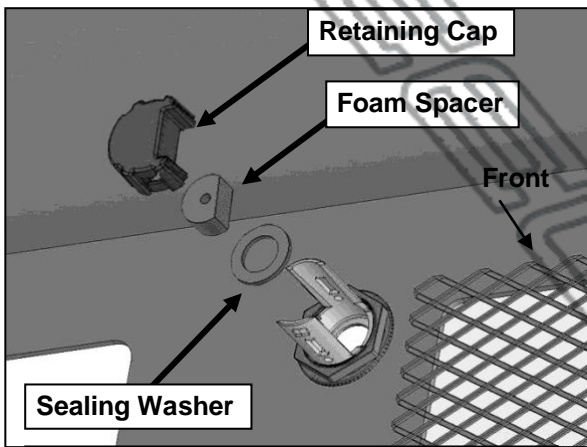

(Fig 20) Insert sensor assembly through the sensor sleeve behind the Bumper

- (3) 6mm x 20mm Hex Bolts
- (6) 6mm Flat Washers
- (3) 6mm Nylon Lock Nuts

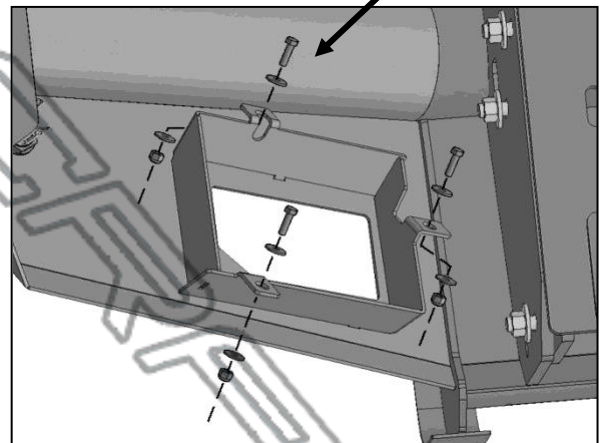

(Fig 21) Attach passenger/right fog light to mounting tabs on driver/left side of Bumper. Reinstall factory wiring harness through Bumper Brackets on back of Bumper.

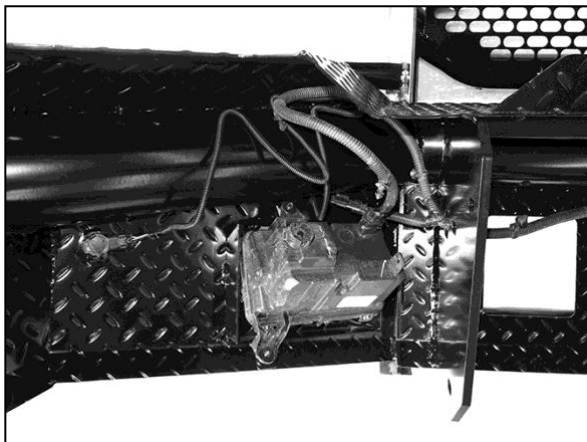

(Fig 22) Use the included (2) Wire Harness Extensions as necessary to reach the parking sensors

**HD REPLACEMENT FRONT BUMPER
2020—23 GMC SIERRA 25-3500**

Driver/left Side Installation Pictured

- (3) 12mm x 50mm Hex Bolts
- (6) 12mm Flat Washers
- (3) 12mm Lock Washers
- (3) 12mm Hex Nuts

WARNING! Do not crawl under bumper unless it is properly supported on blocks or stands or the bumper may fall.

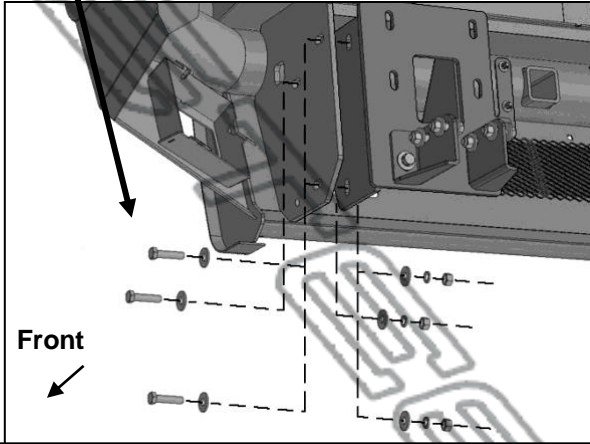

(Fig 23) Attach the Bumper to Frame Brackets



(Fig 24) Driver/left side of Bumper installed

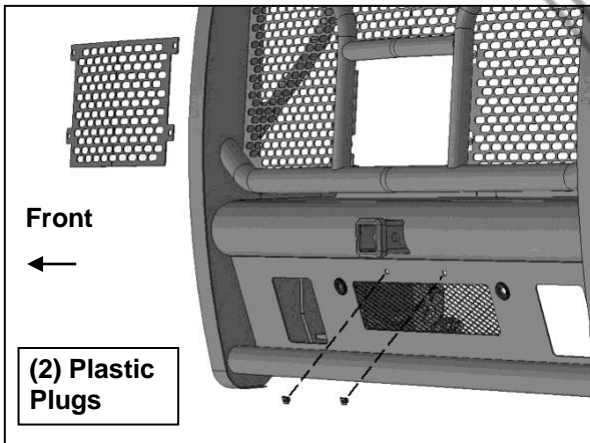

(Fig 25) Models with camera, remove screen. Push Plastic Plugs into hole in Bumper for License Plate

