

**HEAVY DUTY REPLACEMENT FRONT BUMPER
2019-23 DODGE RAM 2500-5500**

PARTS LIST:

1	Heavy Duty Front Bumper Assembly	2	12-1.75mm x 90mm Hex Bolts
2	Frame Mounting Brackets	8	12-1.75mm x 50mm Hex Bolts
1	Driver/left Round Fog Light Mount	20	12mm x 37mm OD x 3mm Flat Washers
1	Passenger/right Round Fog Light Mount	10	12mm Nylon Lock Nuts
1	Driver/left Fog Light Block Off	6	6mm x 25mm Hex Bolts
1	Passenger/right Fog Light Block Off	12	6mm x 22mm x 2mm Flat Washers
2	2mm Slide in Shims for Tow Hook	6	6mm Nylon Lock Nuts
2	3mm Slide in Shims for Tow Hook	8	4mm x 20mm Socket Head Screws
6	15.5mm x 25mm x 2mm Foam Washers	16	4mm x 8.65mm x .8mm Flat Washers
6	Retaining Caps	8	4mm Lock Washers
6	20mm x 10mm Foam Spacers	8	4mm Hex Nuts
6	Sensor Hole Plugs	12	4mm Self Tapping Screws
2	Wiring Harness Extensions	1	4mm Wrench
2	License Plate Mounting Plugs	1	2.5mm Wrench
1	Sensor Cover Kit		

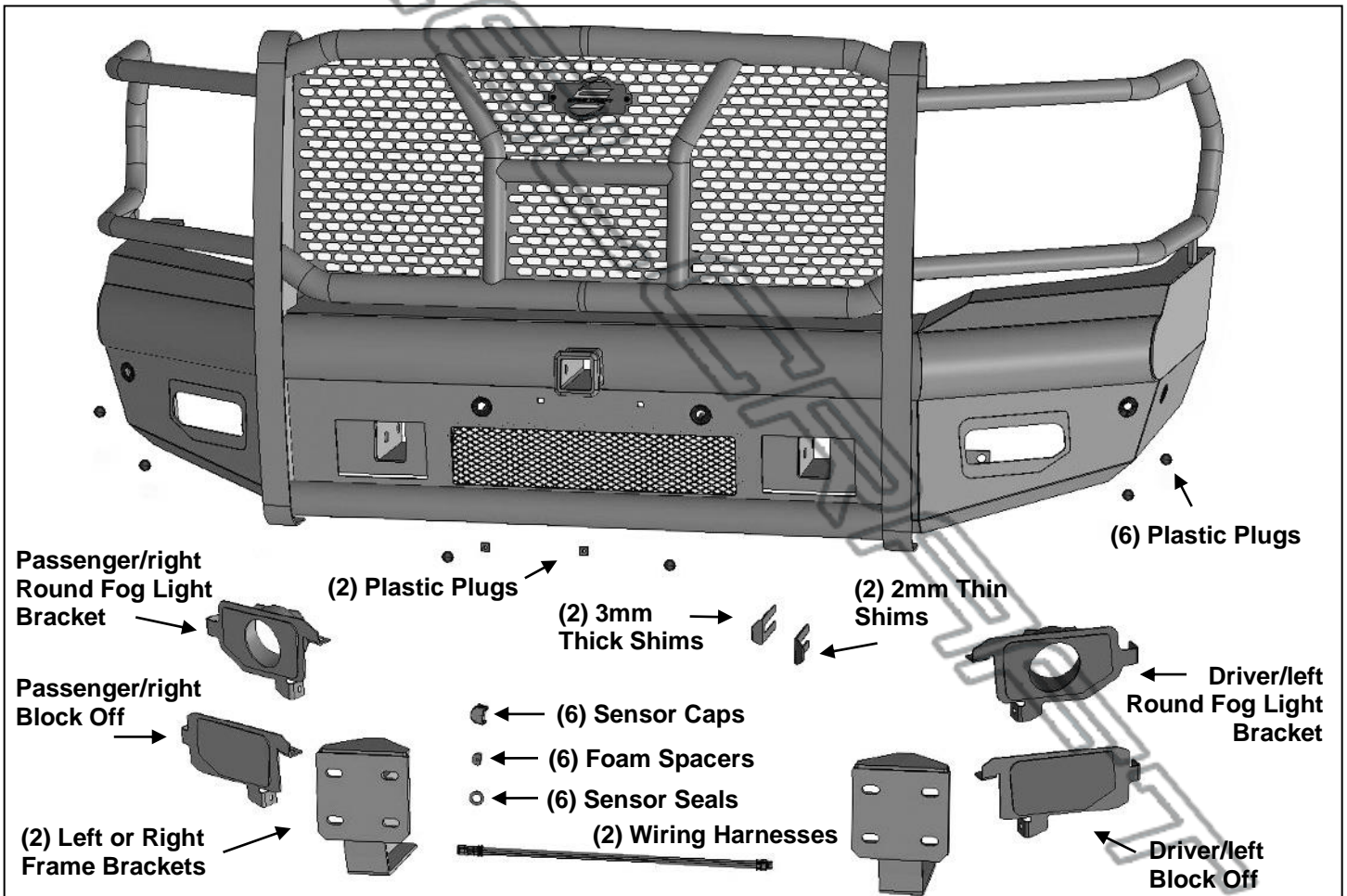

PROCEDURE:

REMOVE CONTENTS FROM BOX. VERIFY ALL PARTS ARE PRESENT. READ INSTRUCTIONS CAREFULLY BEFORE STARTING INSTALLATION. BUMPER IS HEAVY, ASSISTANCE IS HIGHLY RECOMMENDED. CUTTING MAY BE REQUIRED.

1. Remove the license plate. On models with bumper mounted sensors and/or fog lights, unplug the wiring harness leading to the front bumper. Move the wiring harnesses out of the way.

**HEAVY DUTY REPLACEMENT FRONT BUMPER
2019-23 DODGE RAM 2500-5500**

2. Temporarily remove the tow hooks and hardware, **(Figure 1)**.
3. Locate the factory bumper bolts attaching the inner bumper brackets to the end of the frame, **(Figure 1)**. With assistance, remove the (2) long hex bolts per side to remove the bumper assembly, **(Figure 2)**. **WARNING!** Assistance is required to hold the bumper in place during hardware removal to prevent the bumper from falling.
4. Remove the lower frame extension from the driver/left side of the frame, **(Figure 2)**. **NOTE:** Lower frame extension cannot be reinstalled.
5. Select (1) Frame Bracket. Line up the holes in the Bracket with the outside of the driver/left side of the frame. Reuse the (2) factory long hex bolts to attach the Bracket to the end of the frame, **(Figure 3)**. Reuse the (2) hex bolts from the lower frame extension, **(Figure 2)**, to attach the lower mount on the Bracket to the side of the frame.
 - a. Models without "frame extension" and hardware, attach the rear tab on the Mounting Bracket to the factory hole in the side of the frame with the included (1) 12mm x 90mm Hex Bolt, (2) 12mm Flat Washer and (1) 12mm Nylon Lock Nut, **(Figure 4)**.
6. Repeat **Steps 4 & 5** to attach the passenger/right side Mounting Bracket.
7. Carefully remove both fog light assemblies, all sensors and the wiring harness from the back of the OE bumper, **(Figure 5)**. Note location of each sensor for correct reinstallation.

Models without bumper sensors:

- a. From the front of the bumper, push the included Plastic Plugs into sensor mounts, **(Figure 6)**.

Models with bumper mounted sensors:

- a. Select the driver/left outer sensor. Remove the seal from the end of the sensor, **(Figure 7)**. Replace the seal with the included larger Foam Seal.
 - b. Push the sensor into the matching sensor mount on the back of the Bumper.
 - c. Apply (1) Foam Spacer to the plug end of the sensor, **(Figure 8)**.
 - d. Secure the sensor to the socket with (1) Sensor Retaining Cap, **(Figure 8)**.
 - e. Move to the next sensor location. Repeat previous **Steps** to install the next sensor as you go across the Bumper.
 - f. Attach the factory wiring harness to the back of the Bumper. **NOTE:** It may be necessary to remove some of the outer wiring cover to extend the reach of the harness to the sensors. Use the included (2) Wiring Harnesses Extensions to reach outer sensors.
 - g. Secure harness to the Bumper as required.
8. Select the (2) factory tow hooks. Reuse the factory tow hook hardware to attach the tow hooks to the mounts in the Front Bumper. Insert the included Thick and/or Thin Shims as needed along the sides of the tow hook before tightening hardware, **(Figures 9 & 10)**.
 9. With assistance, position the HD Bumper assembly up to the (2) Frame Brackets. **WARNING:** To avoid possible injury or damage to the vehicle, do not proceed until the Bumper is fully and safely supported. Attach the Bumper to the Frame Brackets with (8) 12mm x 50mm Hex Bolts, (16) 12mm Flat Washers and (8) 12mm Nylon Lock Nuts, **(Figures 11 & 12)**. Snug but do not fully tighten hardware.
 10. Level and adjust the Bumper to the vehicle and tighten all hardware.
 11. On models with fog lights, determine style of fog light.

Models equipped with rectangular fog lights:

- a. Select the driver/left fog light assembly. Attach the assembly to the (3) mounting tabs on the back of the Bumper with the included (3) 6mm Bolts, (6) 6mm Flat Washers and (3) 6mm Nylon Lock Nuts, **(Figure 13)**. Repeat this Step to attach the passenger/right fog light assembly.
- b. Plug in the fog light harness to the lights and secure it to the Bumper.

Models equipped with round fog lights.

- a. Remove driver/left fog light mounting bracket from back of Bumper, **(Figure 13)**.
- b. Remove fog light from housing. Attach fog light to Adapter Bracket with (4) 4mm x 20mm Long Screws, (8) 4mm Flat Washers, (4) 4mm Lock Washers and (4) 4mm Hex Nuts, **(Figure 14)**.
- c. Reuse hardware to attach the driver/left Round Fog Light Adapter Bracket to the tabs on the back of the Bumper, **(Figure 15)**.
- d. Repeat previous Steps to attach the passenger/right fog light.
- e. Plug in the fog light harness to the lights and secure it to the Bumper.

Models without fog lights.

**HEAVY DUTY REPLACEMENT FRONT BUMPER
2019-23 DODGE RAM 2500-5500**

- a. Remove the preinstalled driver/left rectangular fog light mount insert from the back of the HD Bumper, **(Figure 13)**.
 - b. Select the driver/left Block Off. Reuse the hardware to attach the Block Off to the tabs on the back of the Bumper, **(Figure 15)**.
 - c. Repeat previous Steps to install the passenger/right Block Off.
- 12.** Install (2) Plastic License Plate Plugs into the holes in the Bumper, **(Figure 16)**. Reuse factory screws to attach license plate to Plugs.
- 13.** On models equipped with forward facing camera, remove the center screen, **(Figure 16)**.
- 14.** Do periodic inspections to the installation to make sure that all hardware is secure and tight.

To protect your investment, Do not use any type of polish or wax that may contain abrasives that could damage the finish. Mild soap may be used to clean the Bumper Assembly

Driver/left Side Installation Pictured

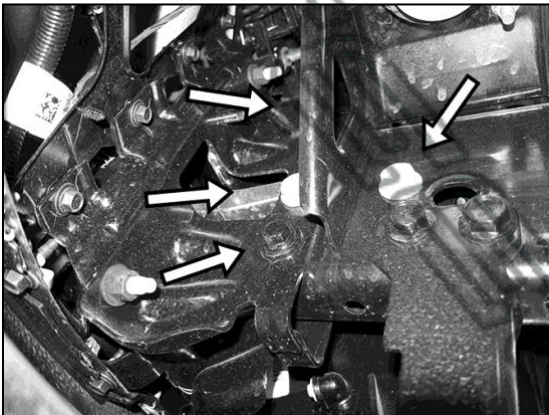

(Fig 1) Locate and remove driver/left side bumper bracket to frame hardware

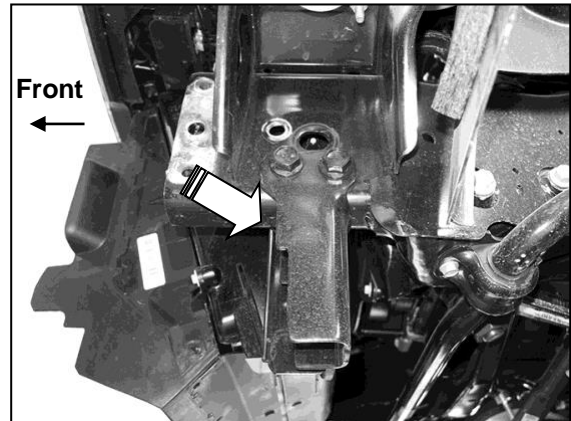

(Fig 2) Remove lower frame extensions (arrow) from bottom of the frame

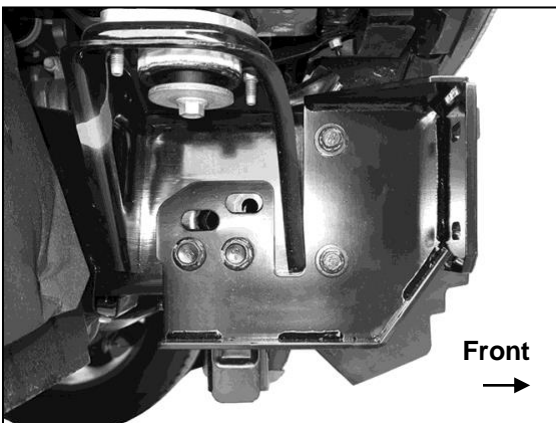

(Fig 3) Reuse factory hardware to attach (1) Frame Bracket to the outside of the frame (passenger/right side pictured)

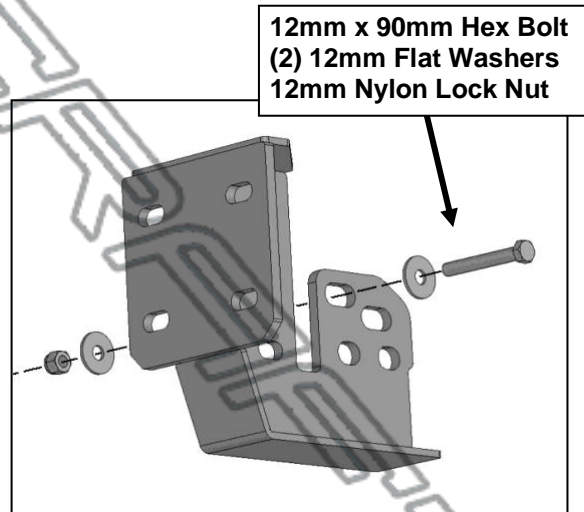

(Fig 4) Models without frame extension, attach rear tab with included 12mm x 90mm Hex Bolts

WARNING! To avoid possible injury or damage to vehicle, do not remove bumper bolts unless the bumper is properly supported on blocks or stands or the bumper may fall.

Driver/left Side Installation Pictured

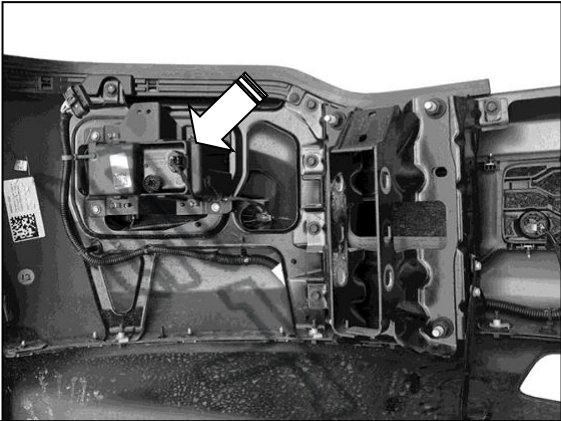

(Fig 5) Remove the wiring harness, sensors and fog light assemblies from bumper (if equipped)

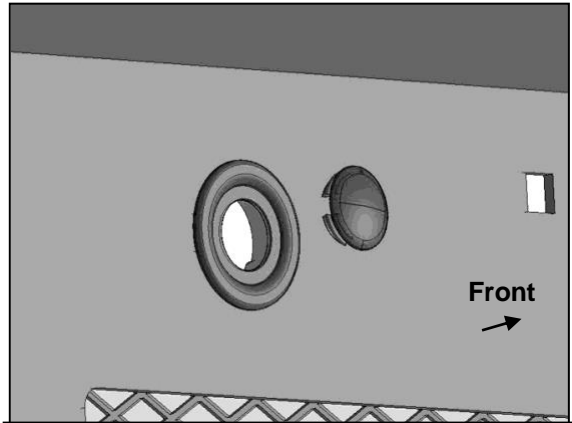

(Fig 6) Push Sensor Hole Plugs into mounts

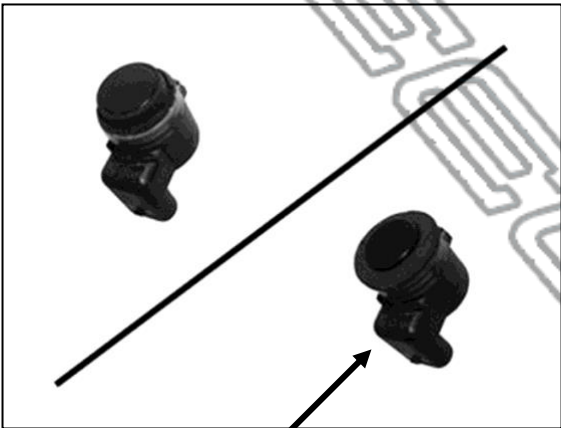

(Fig 7) Remove silicone seal from sensor. Slide large Seal over end of sensor (arrow)

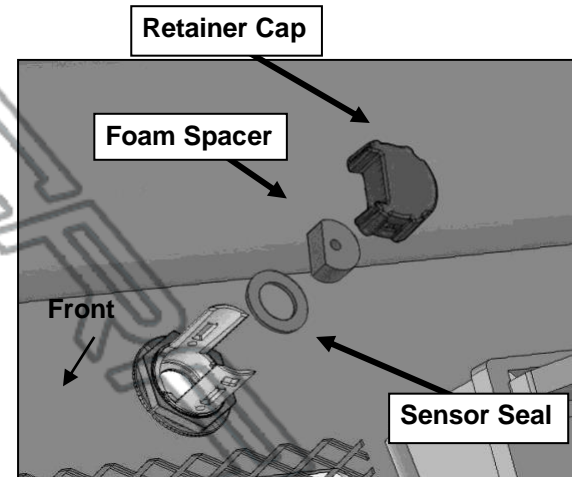

(Fig 8) Slide sensor into sleeve, insert Foam Washer and Clip to lock sensor in sleeve

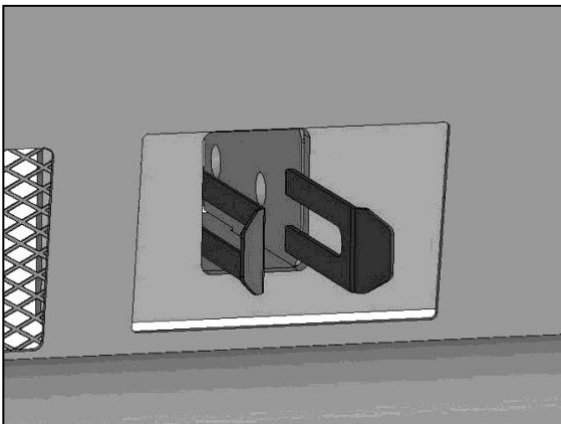

(Fig 9) Slide tow hook into opening in Bumper. Insert Thick or Thin Shim along one or both sides of tow hook as needed to adjust fit of tow hook to mount in Bumper

**HEAVY DUTY REPLACEMENT FRONT BUMPER
2019-23 DODGE RAM 2500-5500**

Driver/left Side Installation Pictured

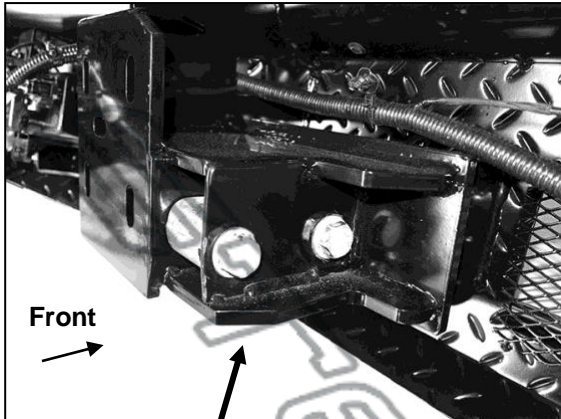

(Fig 10) Reuse factory hardware to attach tow hook to mounts in Bumper (pictured from back of Bumper)

WARNING! Do not crawl under bumper unless it is properly supported on blocks or stands or the bumper may fall.

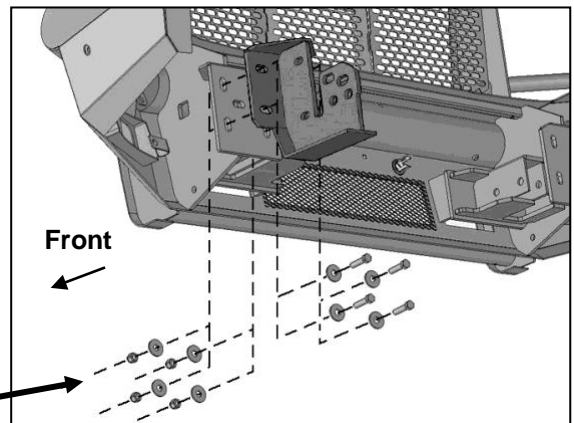

(Fig 11) Attach Bumper to driver/left Bracket

- (4) 12mm x 50mm Hex Bolts
- (8) 12mm Flat Washers
- (4) 12mm Nylon Lock Nuts

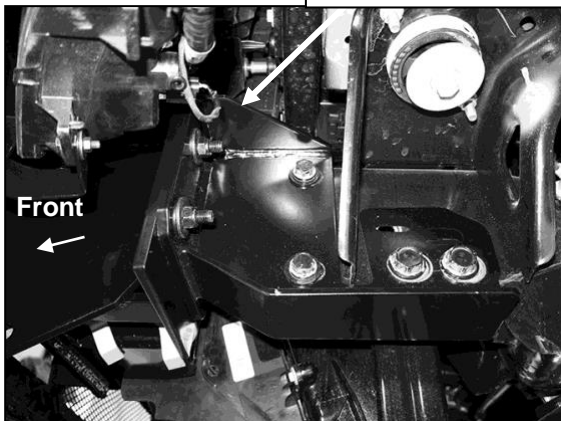

(Fig 12) Driver/left side of Bumper installed

- (3) 6mm x 25mm Hex Bolts
- (6) 6mm Flat Washers
- (3) 6mm Nylon Lock Nuts

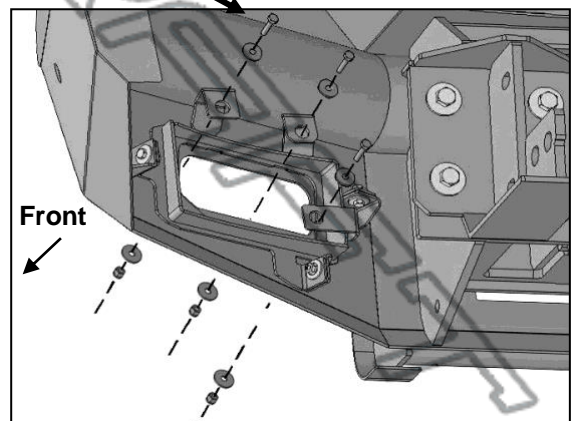

(Fig 13) Attach rectangular fog light assembly to mounts on back of Bumper

HEAVY DUTY REPLACEMENT FRONT BUMPER
2019-23 DODGE RAM 2500-5500

Driver/left Side Installation Pictured

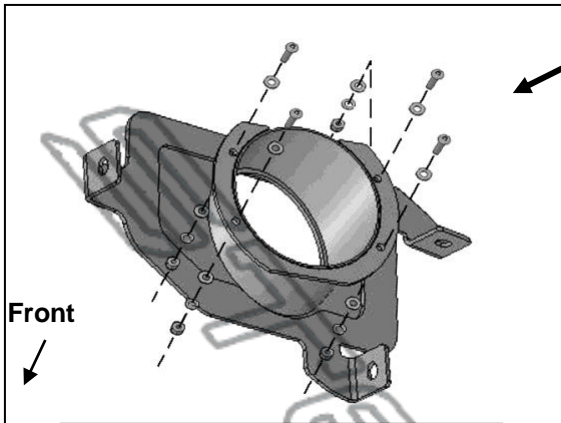

- (4) 4mm x 20mm Long Button Head Screws
- (8) 4mm Flat Washers
- (4) 4mm Lock Washers
- (4) 4mm Hex Nuts

(Fig 14) Attach round fog light to driver/left Adapter Bracket

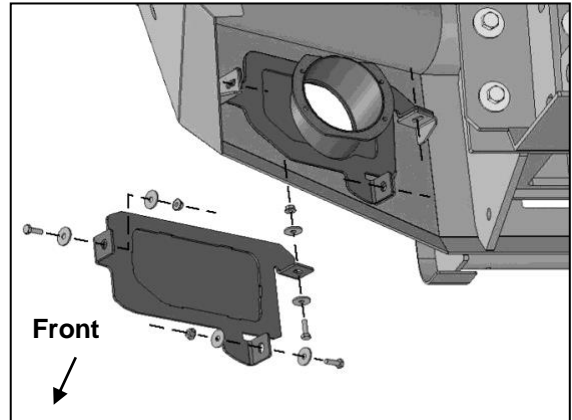

(Fig 15) Reuse hardware to attach Round Fog Light Bracket assembly or Block Off to the tabs on the back of the Bumper

Remove screen from grille for models with grille mounted camera

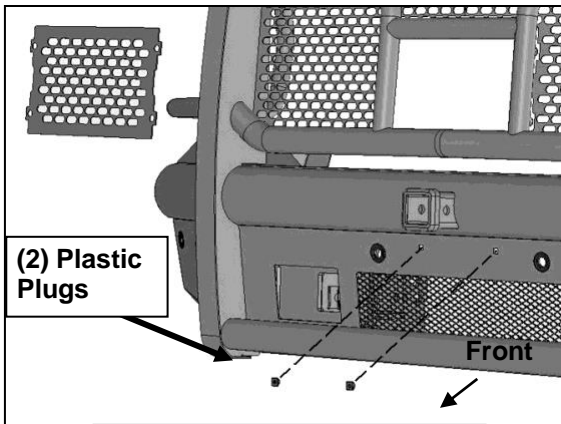

(2) Plastic Plugs

(Fig 16) Attach License Plate Bracket to Bumper



Complete Installation