

**ELEVATION REAR BUMPER  
2005-15 TOYOTA TACOMA**

**PARTS LIST:**

1	Elevation Rear Bumper Assembly	4	14mm Lock Washers
1	Driver/Left Frame Bracket	4	14mm x 28mm x 2.5mm Flat Washers
1	Passenger/Right Frame Bracket	10	12mm x 40mm Hex Bolts
2	Support Brackets	20	12mm x 32mm x 3mm Flat Washers
2	Plastic Plugs (license plate mount)	10	12mm Nylon Lock Nuts
4	14-1.5mm x 55mm <b>Fine Thread</b> Hex Bolts		

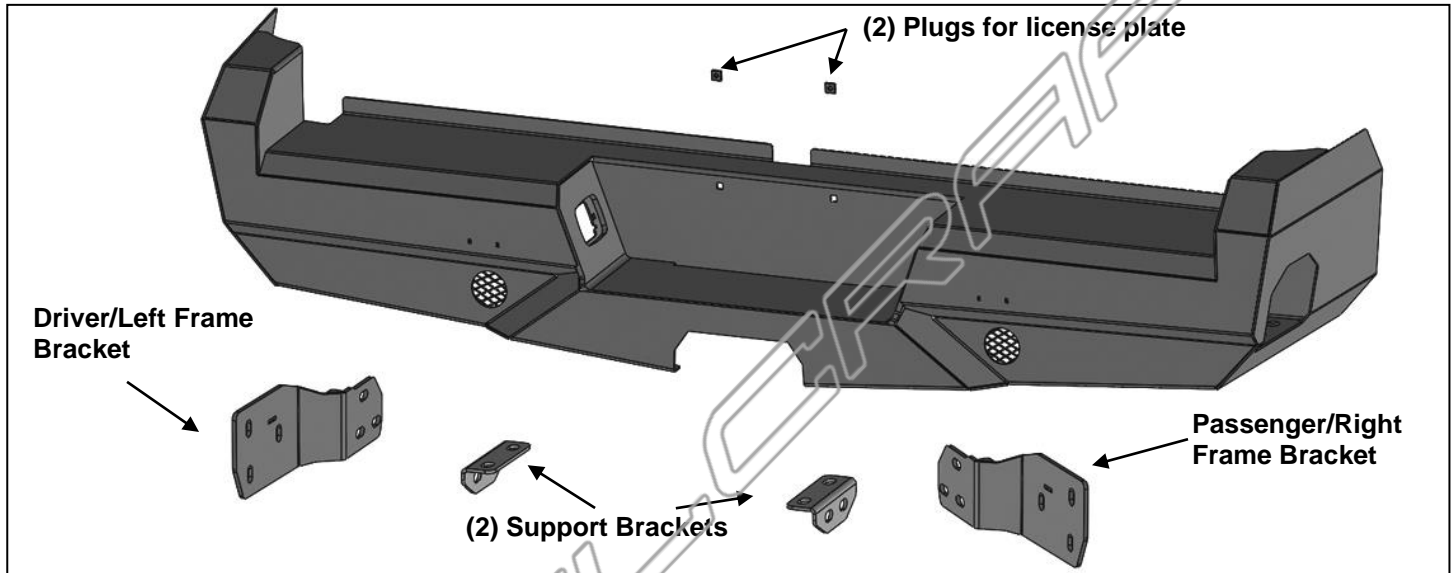

**PROCEDURE:**

**REMOVE CONTENTS FROM BOX. VERIFY ALL PARTS ARE PRESENT. READ INSTRUCTIONS CAREFULLY BEFORE STARTING INSTALLATION. BUMPER IS HEAVY, ASSISTANCE IS RECOMMENDED TO AVOID POSSIBLE INJURY OR DAMAGE TO THE VEHICLE.**

1. Remove the license plate from the bumper. Next, unplug the license plate lights and trailer plug. Release the wiring harness from the clips attached to the back of the bumper, **(Figure 1)**. Move all wiring harnesses away from bumper.
2. **Determine if vehicle is equipped with factory receiver hitch**  
**Models without receiver hitch:**
  - a. Place blocks or jack stands under the bumper to support it during mounting bolt removal. Once the bumper has been safely supported, remove the factory hex bolts, (3 per side), attaching the bumper brackets to the sides of the frame and slide the bumper assembly off of the vehicle.**Models with factory receiver hitch:**
  - a. Remove the plastic cover from the top of the bumper, **(Figure 2)**. **NOTE:** Cover is attached at top, back and bottom by several plastic clips. Use a small flat blade screwdriver to carefully pry up the center pin to release each clip.
  - b. Place blocks or jack stands under the bumper to support it during mounting bolt removal. Once the bumper has been safely supported, remove the factory hardware attaching the bumper to the top and bottom of the receiver hitch and remove the bumper, **(Figures 3, 4 & 5)**. **NOTE:** Leave hitch attached to vehicle.
3. Release the clips securing the trailer plug and remove the plug. Remove license plate lights.
4. **Optional accessory light installation, (sold separately).**
  - a. Attach light to mounting tab on back of bumper. Repeat to install remaining light.
  - b. Follow light manufacturer's instructions for adjustment and to properly wire the light to the vehicle electrical system after Bumper installation.
5. **Models without factory receiver hitch, (models with hitch, skip to Step 6):**

## ELEVATION REAR BUMPER 2005-15 TOYOTA TACOMA

- a. Select (1) Support Bracket, **(Figure 6)**. Attach the Support Bracket to the bottom of the frame with the included (2) 14mm Fine Thread Hex Bolts, (2) 14mm Lock Washers and (2) 14mm Flat Washers. Do not fully tighten hardware at this time.
- b. Repeat the previous Step to install the passenger/right Support Bracket.
6. Select the driver/left Frame Mounting Bracket. Attach the Bracket to the outside of the mounting plate on the back of the Bumper with the included (3) 12mm Hex bolts, (6) 12mm Flat Washers and (3) 12mm Nylon Lock Nuts, **(Figures 7)**. Leave hardware loose at this time. Repeat to attach the passenger/right Frame Bracket to the Bumper.
7. With assistance, hold the Bumper assembly with Brackets up to the outside of the frame and/or hitch. Temporarily support the weight of the Bumper. **WARNING:** To avoid possible injury or damage to the vehicle, do not proceed until the bumper is fully and safely supported.

### Models without factory receiver hitch

- a. Reuse (1) factory hex bolt to attach the top mounting hole in the driver/left Bracket to the side of the frame. **(Figures 8)**. Use (2) 12mm Hex Bolts, (4) 12mm Flat Washers and (2) 12mm Nylon Lock Nuts to attach the Frame Bracket to the Support Bracket. Do not fully tighten hardware at this time.
- b. Repeat to attach the passenger/right Bracket to the vehicle.

### Models with factory receiver hitch

- a. Reuse the (3) factory hex bolts to attach the driver/left Bracket to the outside of the hitch and factory support bracket, **(Figures 9)**.
- b. Repeat to attach the passenger/right Bracket to the vehicle.
8. Level and adjust the bumper and fully tighten all hardware. Slowly open tailgate and check for clearance. Adjust as necessary.
9. Attach the wiring harness to the trailer plug. Secure the wiring harness to the frame as necessary.
10. Use the included (2) push-in plugs to attach the license plate to the Bumper, **(Figure 10)**. Insert the License Plate Light into the hole in the Bumper. Connect the harness to the License Plate Light.
11. Do periodic inspections to the installation to make sure that all hardware is secure and tight.

**To protect your investment**, wax this product after installing. Regular waxing is recommended to add a protective layer over the finish. Do not use any type of polish or wax that may contain abrasives that could damage the finish. Mild soap may be used to clean the Rear Bumper assembly.

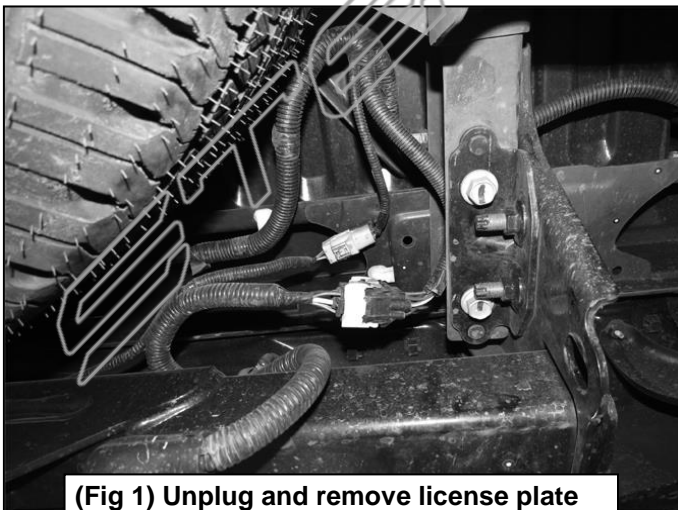

**(Fig 1) Unplug and remove license plate lights and any bumper sensors. Move all wire harnesses away from bumper**



**(Fig 2) Models with receiver hitch only, remove plastic cover from top of bumper to access hex bolts attaching bumper to top of receiver hitch**

Driver/left Side Installation Pictured

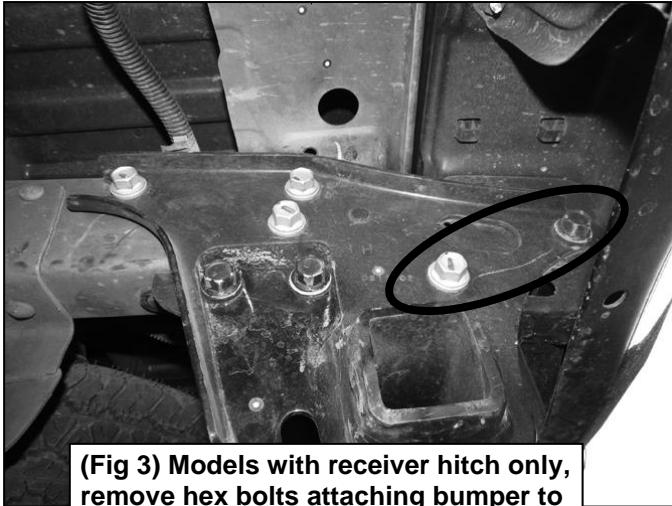

(Fig 3) Models with receiver hitch only, remove hex bolts attaching bumper to side of the receiver hitch

**WARNING!** To avoid injury or damage to the vehicle, do not remove bumper bolts unless the bumper is properly supported on blocks and/or stands or the bumper may fall.

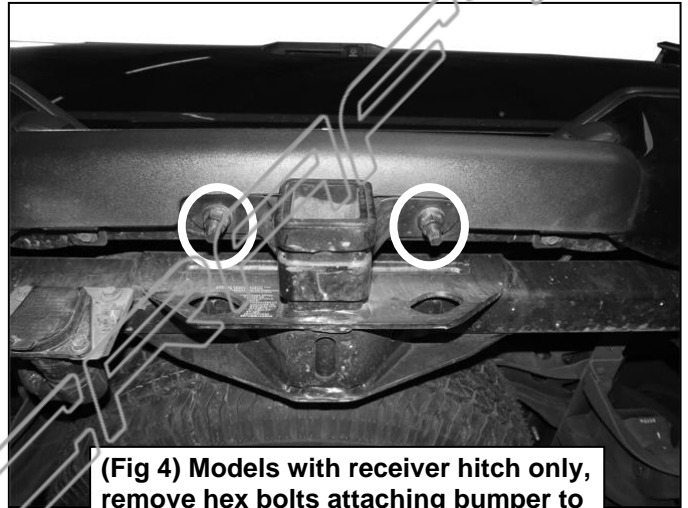

(Fig 4) Models with receiver hitch only, remove hex bolts attaching bumper to bottom of receiver hitch



(Fig 5) Models with receiver hitch only, remove bumper but leave receiver hitch attached

- (2) 14mm x 55mm Hex Bolts
- (2) 14mm Lock Washers
- (2) 14mm Flat Washers

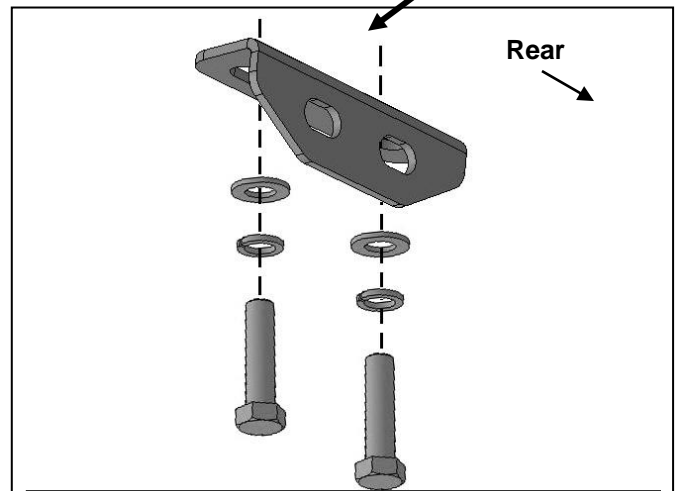

(Fig 6) Attach Support Brackets to frame (required on models without receiver hitch only)

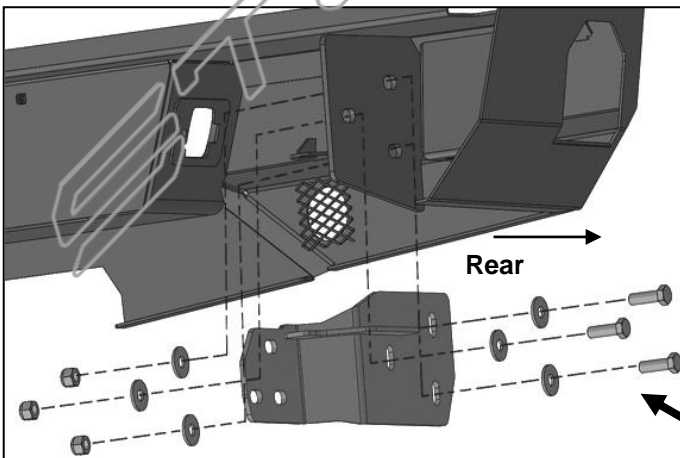

(Fig 7) Attach Driver/Left Frame Bracket to inside of Bumper. Leave hardware loose at this time

- (3) 12mm x 40mm Hex Bolts
- (6) 12mm Flat Washers
- (3) 12mm Nylon Lock Nuts

Driver/left Side Installation Pictured

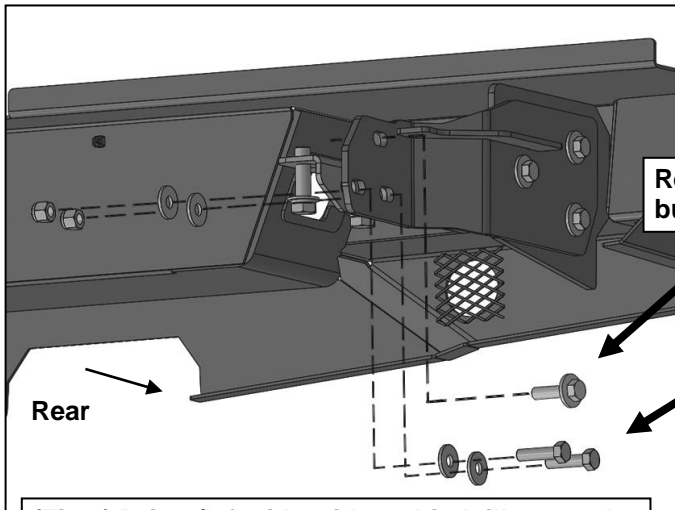

(Fig 8) Driver/left side without hitch illustrated

License Plate  
Lights

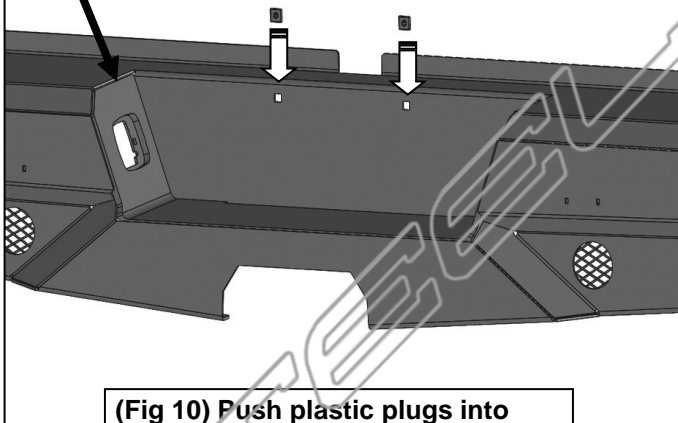

(Fig 10) Push plastic plugs into  
holes in Bumper for license plate

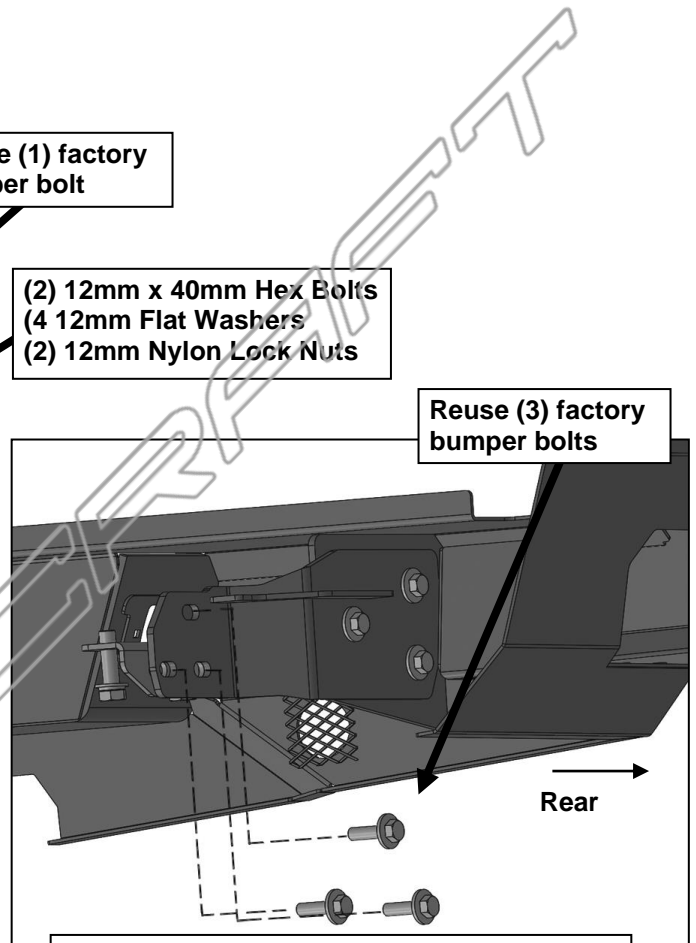

(Fig 9) Driver/left side with hitch illustrated

Complete Installation

