

PARTS LIST:

1	Grille Guard	8	10-1.5mm x 35mm Hex Bolts
1	Driver/Left Frame Mounting Bracket	18	10mm x 27mm x 3mm Flat Washers
1	Passenger/Right Frame Mounting Bracket	10	10mm Nylon Lock Nuts
1	Driver/Left Lower Support Bracket	4	8-1.25mm x 25mm Hex Bolts
1	Passenger/Right Lower Support Bracket	2	8-1.25mm x 20mm Button Head Bolts
1	Driver/Left Top Support Mount Bracket	10	8mm x 22mm x 2mm Flat Washers
1	Passenger/Right Top Support Mount Bracket	2	8mm Lock Washers
1	Driver/Left Top Support Bracket	4	8mm Nylon Lock Nuts
1	Passenger/Right Top Support Bracket	4	6mm x 20mm Button Head Combo Bolts
2	Adhesive Backed Foam Tape	1	5mm Wrench
2	10mm Fish Wires	1	4mm Wrench
2	10mm x 35mm Bolt Plates		

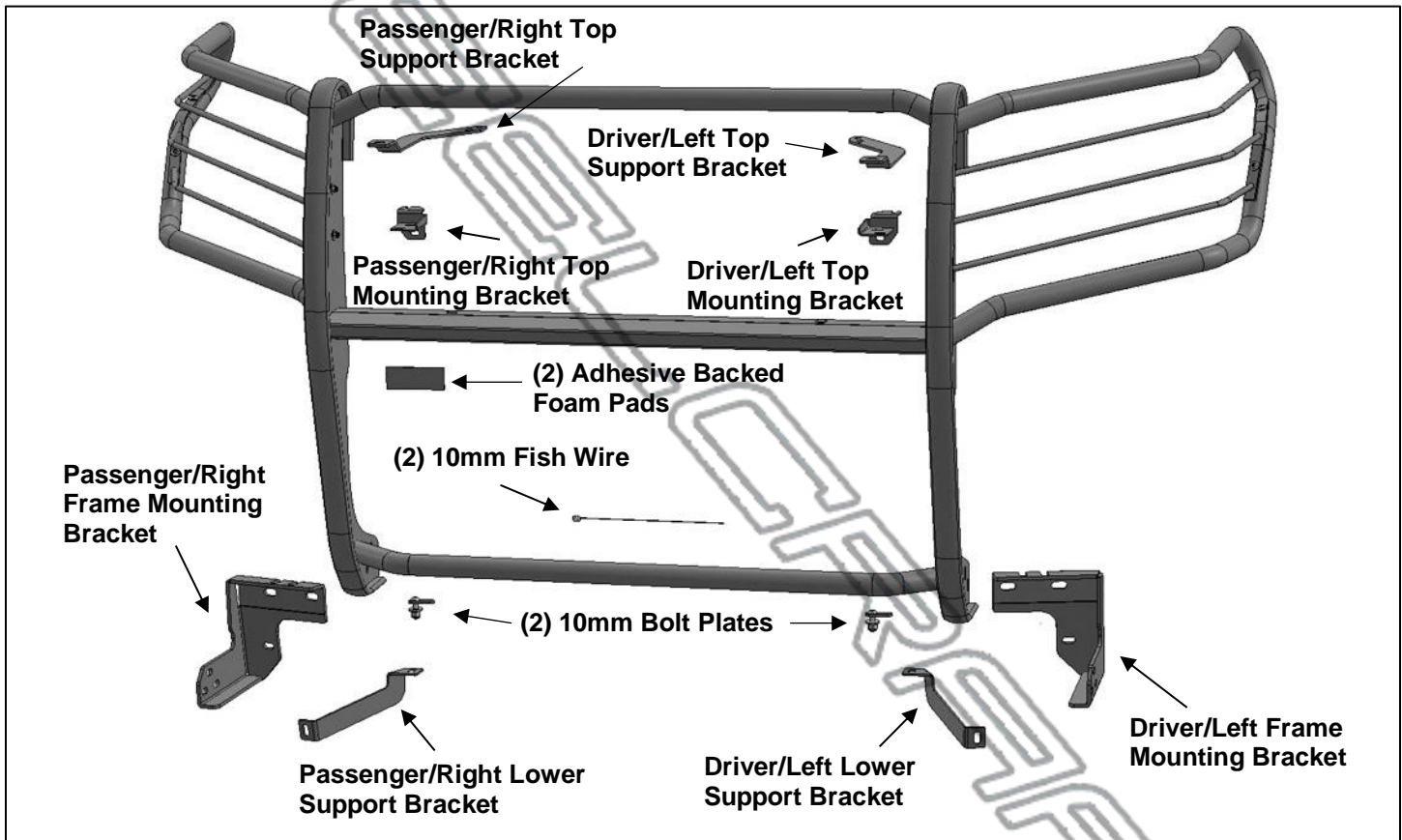

PROCEDURE:

REMOVE CONTENTS FROM BOX. VERIFY ALL PARTS ARE PRESENT. READ INSTRUCTIONS CAREFULLY BEFORE STARTING INSTALLATION. INSTALLATION MAY INTERFERE WITH FRONT MOUNTED SENSORS. MODELS WITH "PARKING BRAKE SUPPORT SYSTEM" MUST TURN OFF SYSTEM. ON MODELS WITH ELECTRIC AIR DAM, AIR DAM MUST BE REMOVED FROM ELECTRIC MOTOR AND CANNOT BE REINSTALLED.

1. Start installation under the Passenger/Right front of the vehicle. Locate the end of the frame and impact bumper just behind the outer bumper cover. Temporarily remove the (4) factory bolts and "L" bent bracket, **(Figure 1)**. **NOTE:** Bracket will not be reinstalled.
2. Select the Passenger/Right Frame Mounting Bracket. Reuse the factory bolts to attach the Mounting Bracket to the frame and bottom of the impact bumper, **(Figures 2 & 3)**. Do not fully tighten hardware at this time.

3. Select (1) 10mm Bolt Plate and (1) 10mm Fish Wire. Thread the Fish Wire onto the Bolt Plate, **(Figure 4)**. Bend the straight end of the Fish Wire into a hook, Insert the bent end of the Fish Wire into the large hole in the bottom of the frame crossmember, **(Figure 5)**. Guide the Fish Wire into the large hole and back out the smaller hole toward the outside of the frame. Pull the Fish Wire and Bolt Plate into and down out of the frame, **(Figure 6)**. **NOTE:** The 10mm Fish Wire has been provided to help with Bolt Plate installation. Use is optional.
4. Select the Passenger/Right Lower Support Bracket, **(Figure 7)**. Attach the Support Bracket to the Bolt Plate with (1) 10mm Flat Washer and (1) 10mm Nylon Lock Nut. Attach the forward end of the Support Bracket to the back of the Frame Mounting Bracket with (1) 10mm x 35mm Hex Bolt, (2) 10mm Flat Washers, and (1) 10mm Nylon Lock Nut, **(Figures 8 & 9)**. Do not tighten hardware.
5. Repeat **Steps 1—4** to attach the Driver/Left Frame Bracket and Lower Support Bracket to the frame.
6. Open the hood and locate the (2) hex bolts in the passenger/right side of the radiator core support, **(Figure 10)**. Select the passenger/right Top Support Mounting Bracket, **(Figure 11)**. Attach the Bracket to the threaded holes in the core support with the included (2) 6mm x 20mm Button Head Combo Bolts, **(Figure 12)**. Do not fully tighten hardware.
7. Next, select the passenger/right Top Support Bracket and (1) Adhesive Backed Foam Pad, **(Figure 13)**. Apply the Foam Pad to the bottom of the Top Support Bracket.
8. Insert the flat end of the Top Support Bracket through the top outer opening in the grille, **(Figure 14)**. **NOTE:** Release the plug on the passenger/right side and move the harness to clear the Support Bracket, if necessary, **(Figure 15)**.
9. Attach the flat end of the Bracket to the top of the Top Mounting Bracket with the included (2) 8mm x 25mm Hex Bolts, (4) 8mm Flat Washers and (2) 8mm Nylon Lock Nuts, **(Figures 16 & 17)**. Do not fully tighten hardware at this time.
10. Repeat **Steps 6—9** to install the driver/left Top Mounting and Support Brackets.
11. With assistance, hold the Grille Guard up to the outside of the Frame Mounting Brackets. Attach the Grille Guard to the passenger/right Bracket with the included (3) 10mm x 35mm Hex Bolts, (6) 10mm Flat Washers and (3) 10mm Nylon Lock Nuts, **(Figures 18 & 19)**. Repeat this **Step** to attach the driver/left side of the Grille Guard. Do not fully tighten hardware.
12. Attach the passenger/right Upper Support Bracket to the bottom of the top tube on the Grille Guard with the included 8mm x 20mm Button Head Bolt, (1) 8mm Lock Washer and (1) 8mm Flat Washer, **(Figure 20)**. Repeat this **Step** to attach the drive/left Upper support Bracket to the Grille Guard.
13. Level and adjust the Grille Guard and fully tighten all hardware.
14. Do periodic inspections to the installation to make sure that all hardware is secure and tight.

To protect your investment, wax this product after installing. Regular waxing is recommended to add a protective layer over the finish. Do not use any type of polish or wax that may contain abrasives that could damage the finish.

For stainless steel: Aluminum polish may be used to polish small scratches and scuffs on the finish. Mild soap may be used also to clean the Grille Guard.

For gloss black finishes: Mild soap may be used to clean the Grille Guard.

Passenger/Right Side Installation Pictured

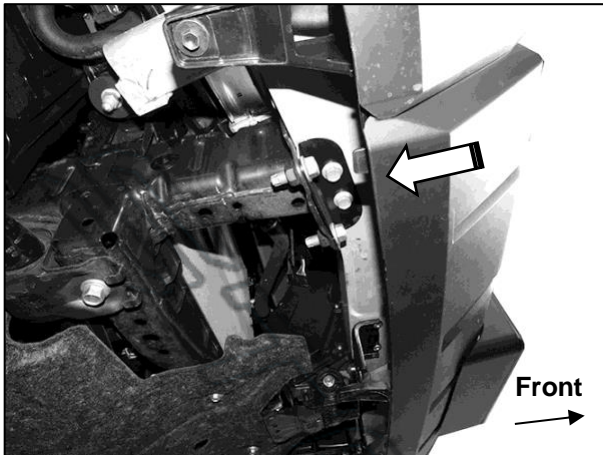

(Fig 1) Temporarily remove the (4) bolts and bent bracket attaching the bottom of the inner impact bumper to the end of the frame (arrow)

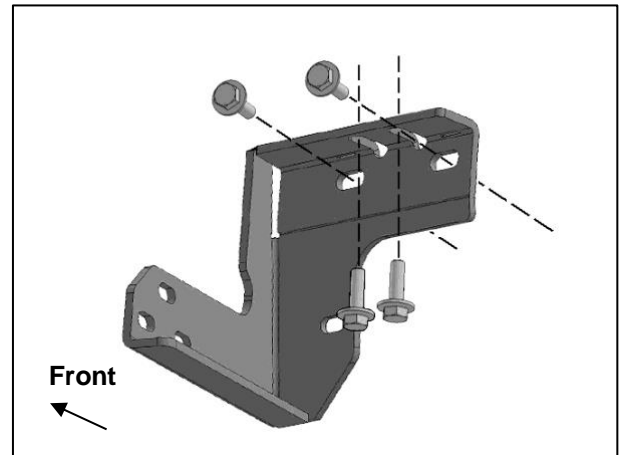

(Fig 2) Reuse the factory hardware to attach the Passenger/Right Mounting Bracket to the frame and inner impact bumper

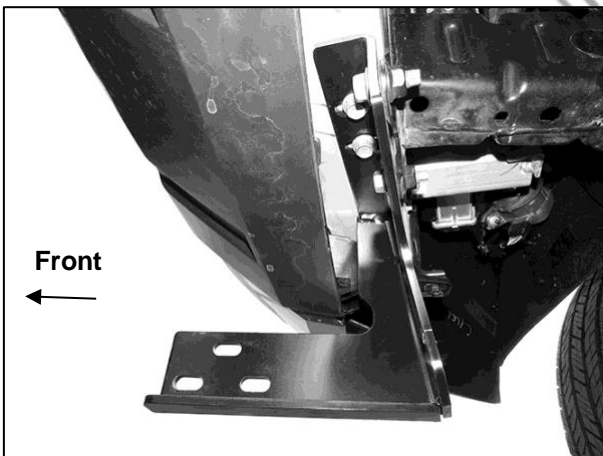

(Fig 3) Passenger/right Frame Mounting Bracket installed

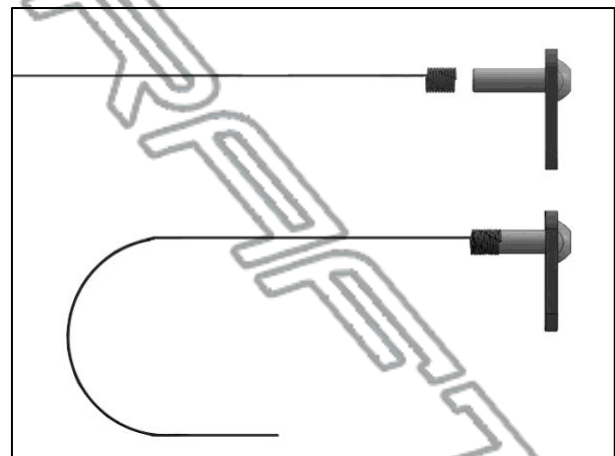

(Fig 4) Thread (1) 10mm Fish Wire onto (1) 10mm Bolt Plate. Bend the straight end of the Fish Wire into a "U"

Passenger/Right Side Installation Pictured

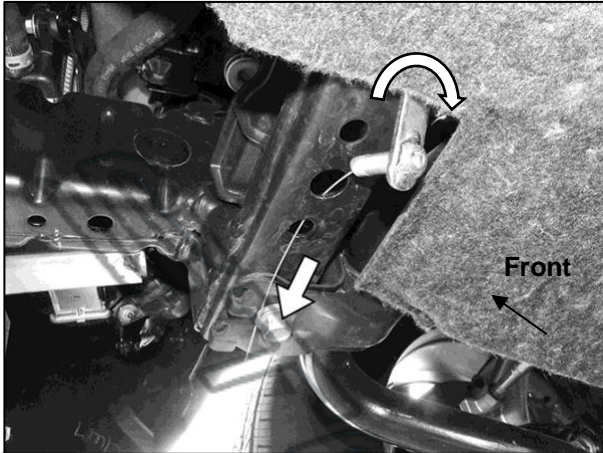

(Fig 5) Insert the U-bent end of the Fish Wire into the large hole and out the outer smaller hole. Pull the Fish Wire with Bolt Plate into and through the hole in the crossmember. NOTE: Bolt Plate as pictured must be rotated 180 degrees to fit into hole

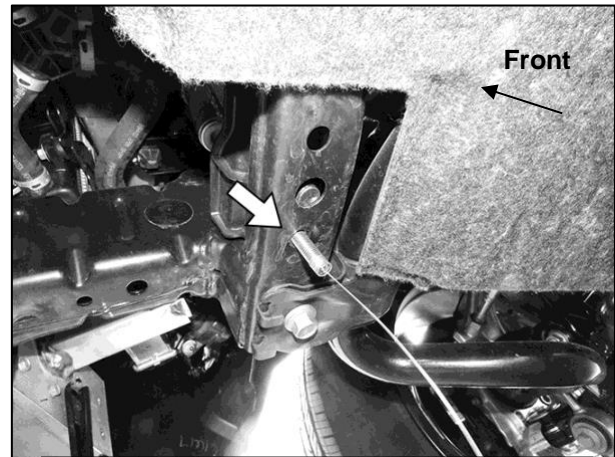

(Fig 6) Pull the Fish Wire with Bolt Plate down and out through the smaller hole in the crossmember then remove Fish Wire. NOTE: Use of Fish Wire to install the Bolt Plate is optional

- 10mm Bolt Plate
- 10mm Flat Washer
- 10mm Nylon Lock Nut

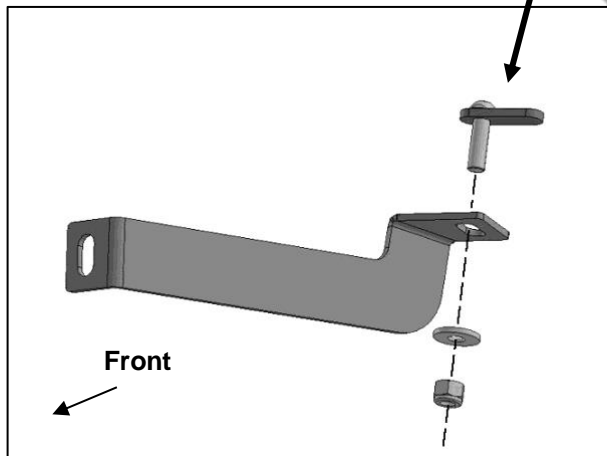

(Fig 7) Attach the Passenger/Right Support Bracket to the Bolt Plate

- 10mm x 35mm Hex Bolt
- (2) 10mm Flat Washers
- 10mm Nylon Lock Nut

- 10mm Bolt Plate
- 10mm Flat Washer
- 10mm Nylon Lock Nut

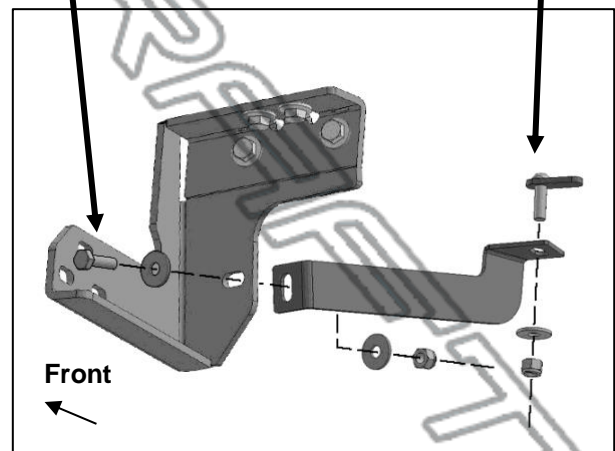

(Fig 8) Attach the Passenger/Right Support Bracket to the back of the Mounting Bracket

Passenger/Right Side Installation Pictured

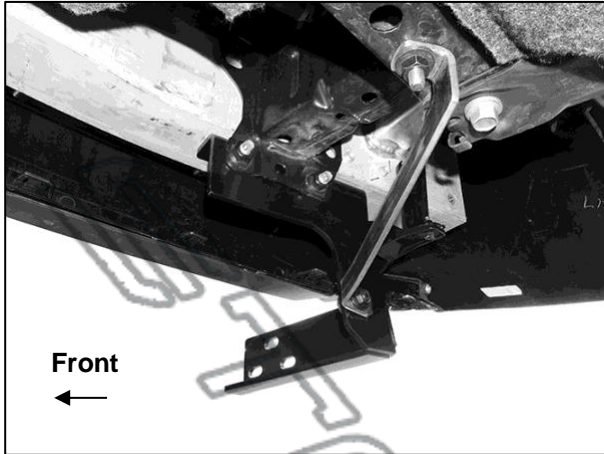

(Fig 9) Passenger/Right Frame Bracket and Support Bracket installed

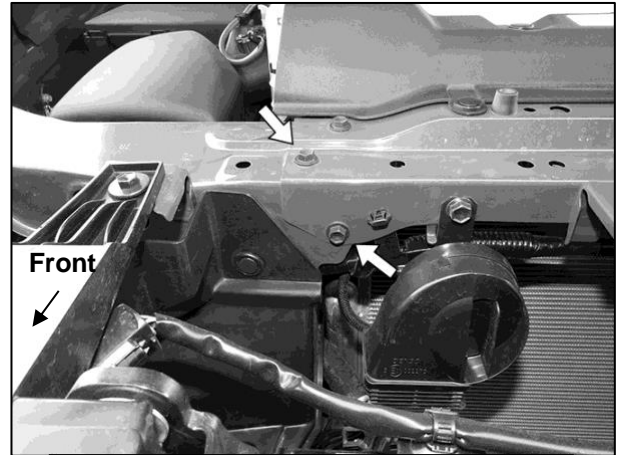

(Fig 10) Remove the (2) hex bolts from the passenger/right side of the radiator core support (arrows)

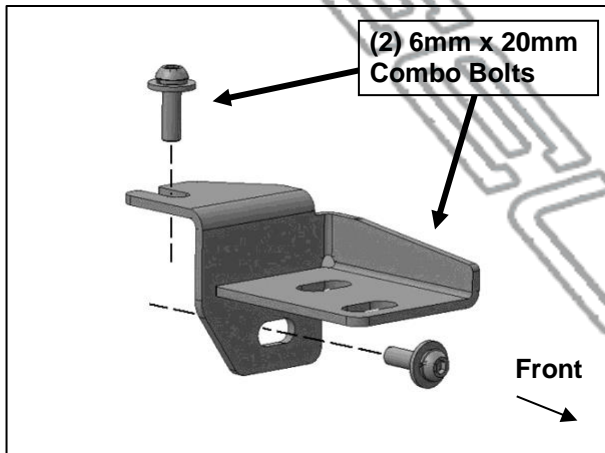

(Fig 11) Attach the passenger/right Upper Mounting Bracket to the core support

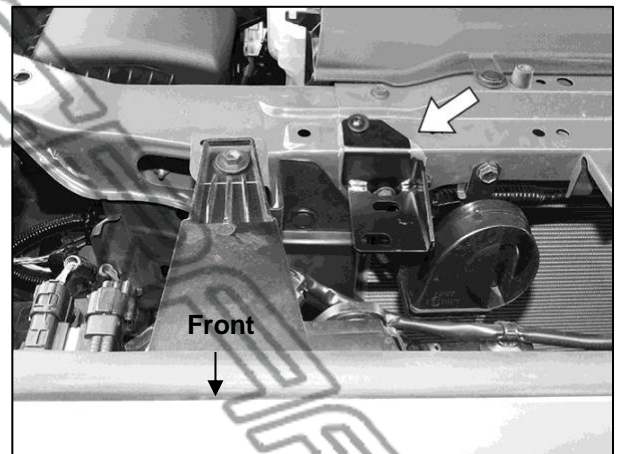

(Fig 12) Attach the passenger/right Upper Mounting Bracket to the core support

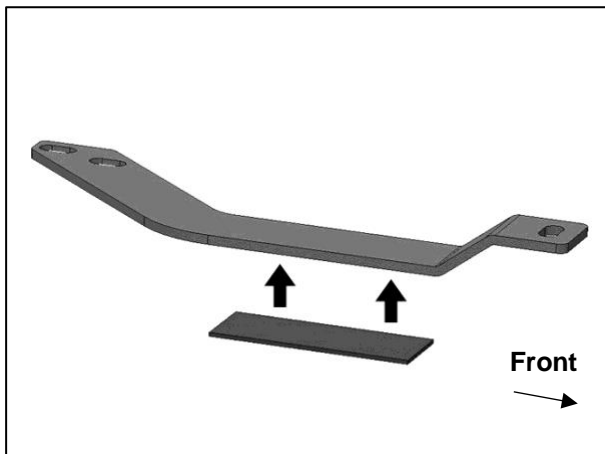

(Fig 13) Apply the Adhesive Backed Foam Pad to the bottom of the passenger/right Support Bracket

Passenger/Right Side Installation Pictured

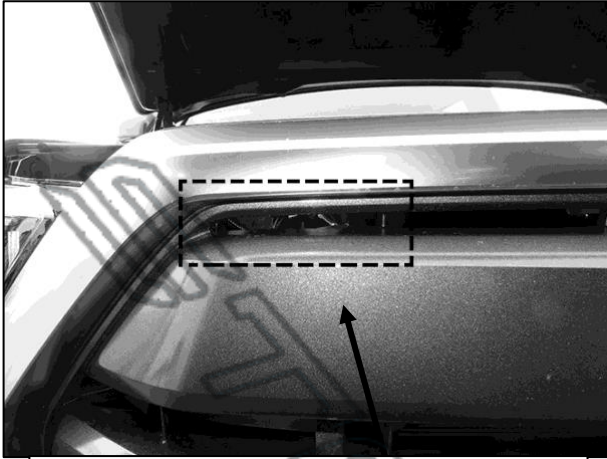

(Fig 14) Insert the flat end of the passenger/right Upper Support Bracket through the top outer opening in the grille

- (2) 8mm x 25mm Hex Bolts
- (4) 8mm Flat Washers
- (2) 8mm Nylon Lock Nuts

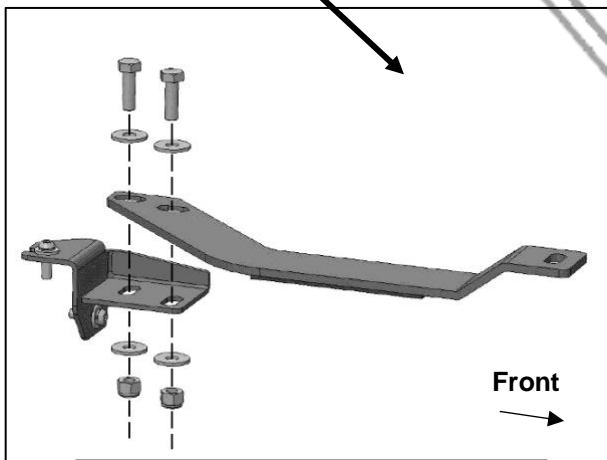

(Fig 16) Attach the passenger/right Upper Support Bracket to the top of the Mounting Bracket

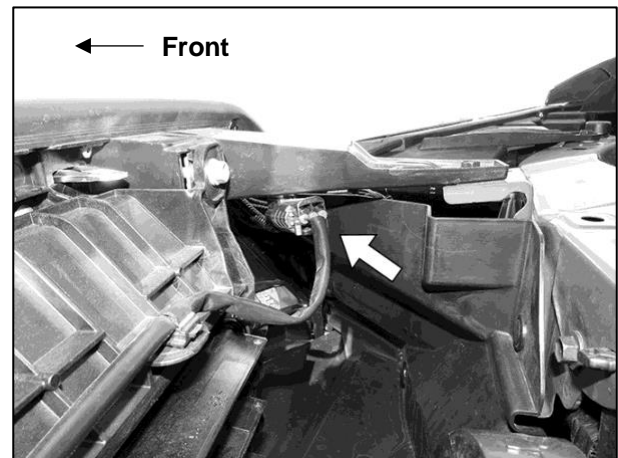

(Fig 15) Relocate the wiring harness on the passenger/right side of the grille to clear the Support Bracket if necessary

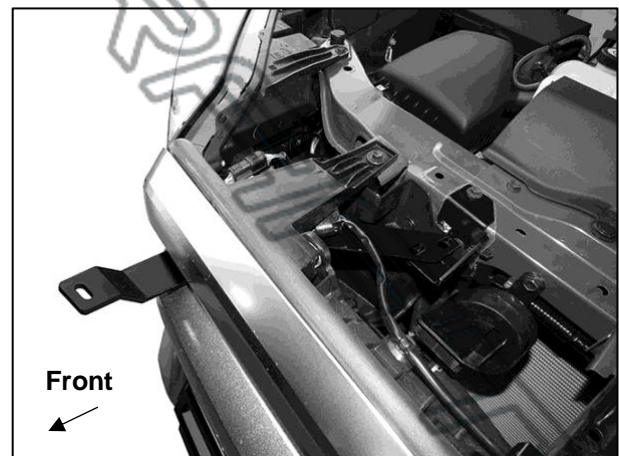

(Fig 17) Passenger/right Upper Support Bracket installed

Passenger/Right Side Installation Pictured

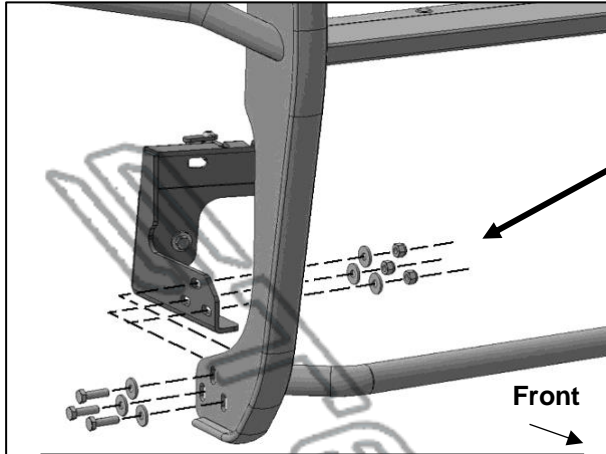

- (3) 10mm x 35mm Hex Bolts
- (6) 10mm Flat Washers
- (3) 10mm Nylon Lock Nuts

(Fig 18) Attach passenger/right side of Grille Guard to Frame Mounting Bracket

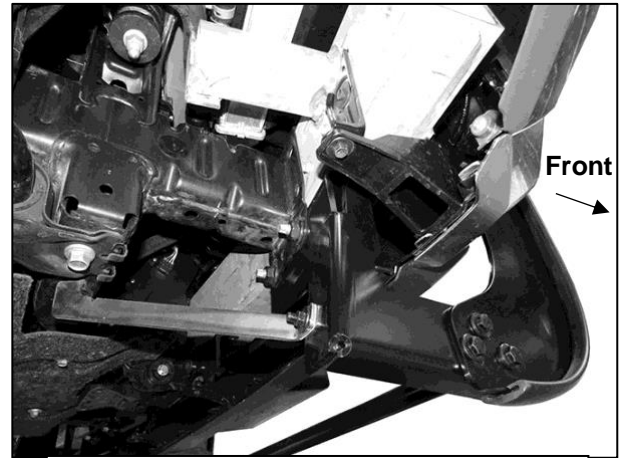

(Fig 19) Attach passenger/right side of Grille Guard to Frame Mounting Bracket

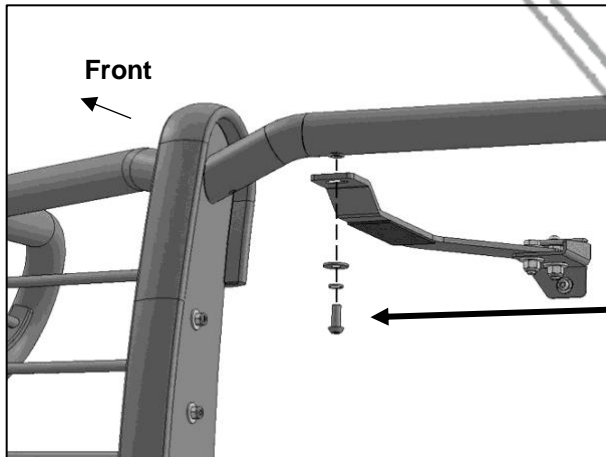

- 8mm x 20mm Button Head Bolt
- 8mm Lock Washer
- 8mm Flat Washer

(Fig 20) Attach passenger/right Support Bracket to top tube on Grille Guard



Complete Installation