

PARTS LIST:

2	Universal Mounting Tubes (78"	12	8mm Lock Washers
6	Mounting Brackets	12	8-1.25mm Hex Nuts
4	DS5 Drop Steps	24	8mm x 24mm x 2mm Flat Washers
8	Plate Washers	16	8-1.25mm Nylon Lock Nuts
28	8-1.25mm x 25mm T-Bolts	2	Left Plastic End Caps
12	8mm Flanged Serrated Hex Nut	2	Right Plastic End Caps

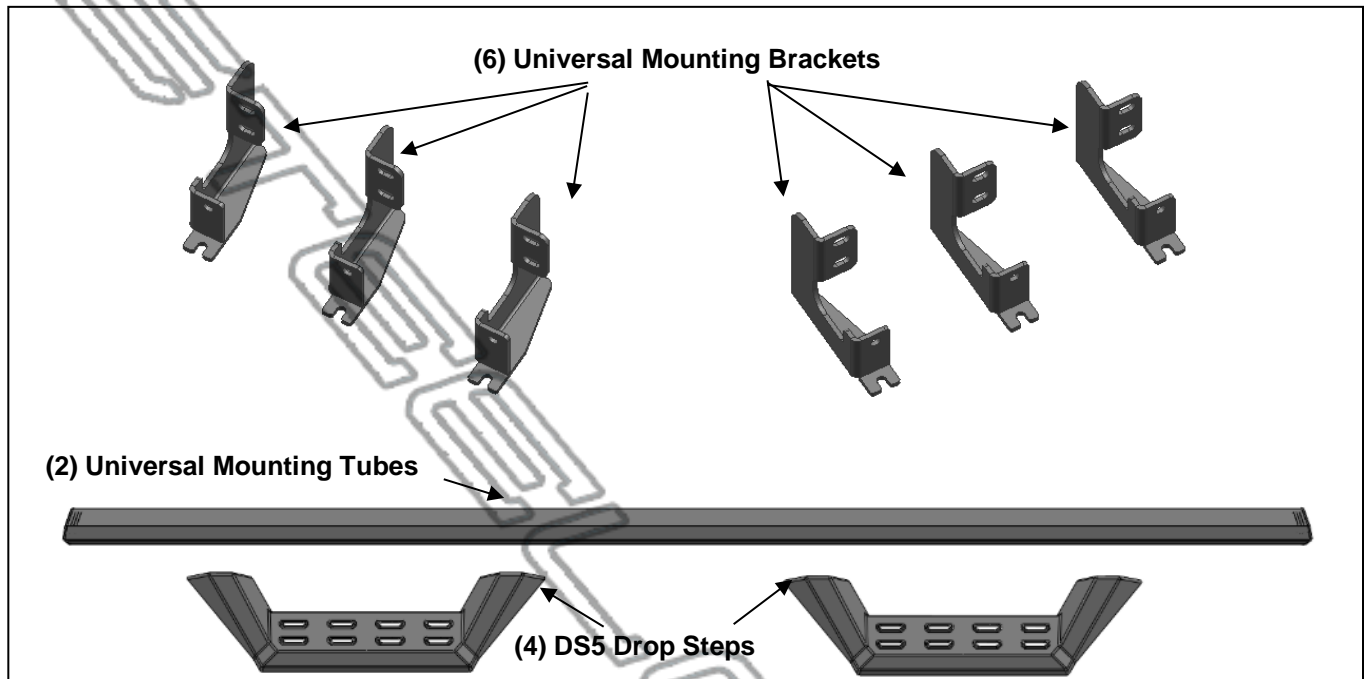

PROCEDURE:

REMOVE CONTENTS FROM BOX. VERIFY ALL PARTS ARE PRESENT. READ INSTRUCTIONS CAREFULLY. ASSISTANCE IS RECOMMENDED.

- Starting on the Passenger/Right front of the vehicle, **(Figure 1)**. Attach (1) Mounting Bracket to the front location with (2) 8mm Flat Washers and (2) 8mm Flange Nuts, **(Figures 2-3)**. Do not tighten hardware.
- Repeat **Step 1** to attach the remaining (2) Mounting Brackets to the Passenger/Right center and rear locations, **(Figures 4-5)**.
- Select the Universal Mounting Tube. Select (6) 8mm T-bolts. Insert the T-bolts into the rear and bottom channels of the Universal Mounting Tube, **(Figure 6)**. Guide the T-bolts to the general position of the Mounting Brackets.
- Take (6) 8mm T-bolts. Insert the T-bolts into the front channels of the Universal Mounting Tube **(Figure 7)**. Each front channel should have (4) T-bolts, which corresponds to the holes on the DS5 Drop Steps.
- Attach the DS5 Drop Steps to the Universal Mounting Tube. Each DS5 Drop Step uses (2) 8mm Plate Washers and (4) 8mm Nylon Lock Nuts, **(Figure 8—9)**. Do not tighten hardware. While the hardware is not tightened, the Drop Steps will slide along the length of the channels.
- Take (2) Plastic End Caps. Insert the correctly oriented Plastic End Caps onto the ends of the Universal Mounting Tube, **(Figure 10)**. It is recommended to secure one end and to use a rubber mallet to carefully tap the Plastic End Caps into place on the other end. Inspect the installed Plastic End Caps to see if they are facing the correct direction.
- Attach the Universal Mounting Tube to the Mounting Brackets. Each Mounting Bracket uses (2) 8mm Flat Washers, (2) 8mm Lock Washers and (2) 8mm Hex Nuts, **(Figure 11—12)**. Do not tighten hardware.
- Level and adjust the Universal Mounting Tube and tighten all hardware.
- Adjust the DS5 Drop Steps by sliding them to the desired positions. Tighten all hardware to secure the Drop Steps in place.

10. Repeat **Steps 1—9** to attach the other Running Board.

11. Do periodic inspections to the installation to make sure that all hardware is secure and tight.

To protect your investment, Do not use any type of polish or wax that may contain abrasives that could damage the finish. Use only mild soap to clean the Running Boards.

Passenger/Right Side Installation Pictured

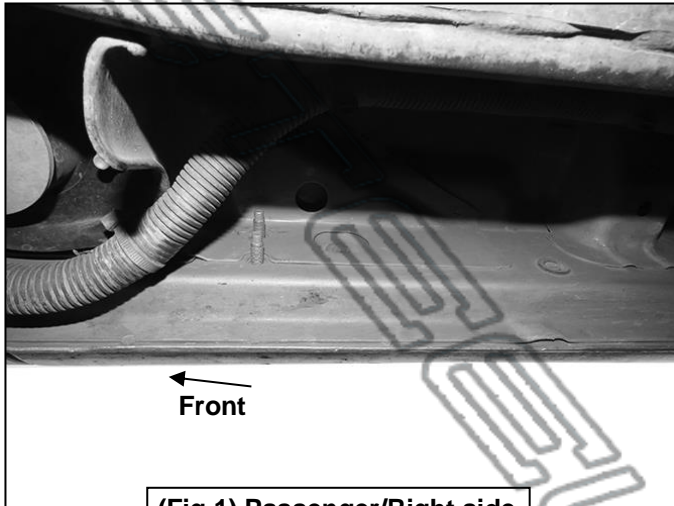

(Fig 1) Passenger/Right side front mounting location

(2) 8mm Flat Washers
(2) 8mm Flange Nuts

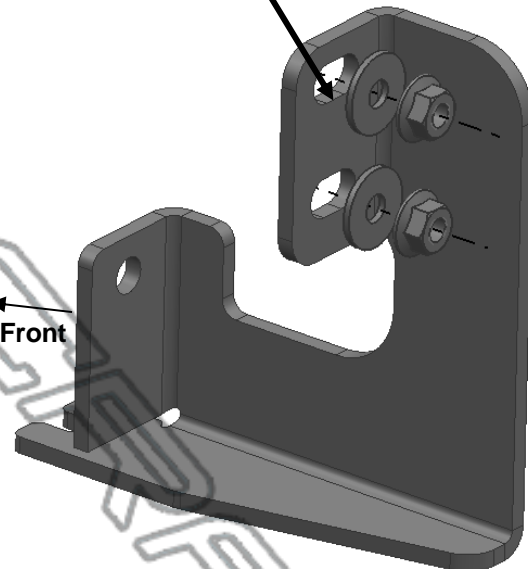

(Fig 2) Attach (1) Mounting Bracket to the front location

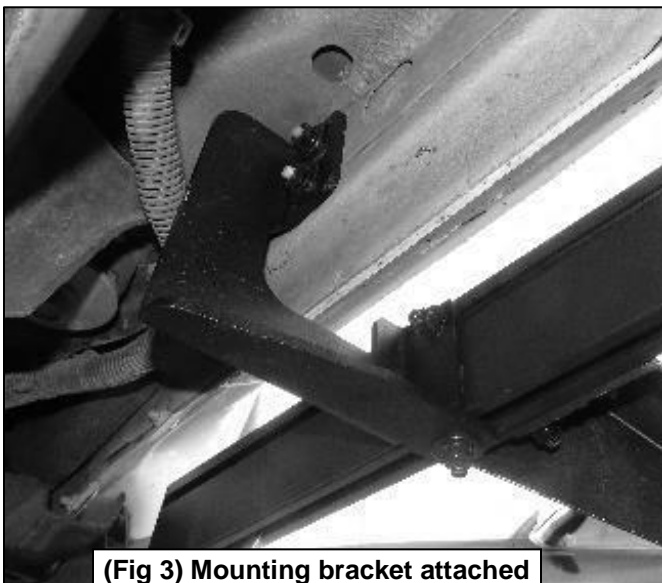

(Fig 3) Mounting bracket attached to the front mounting location

Passenger/Right Side Installation Pictured

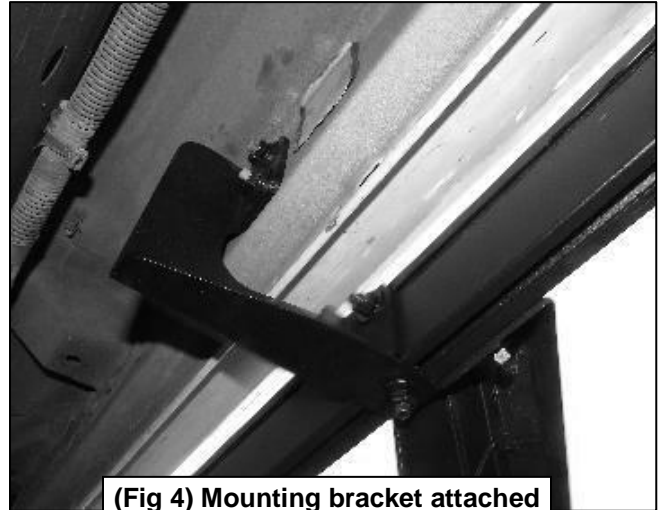

(Fig 4) Mounting bracket attached to the center mounting location

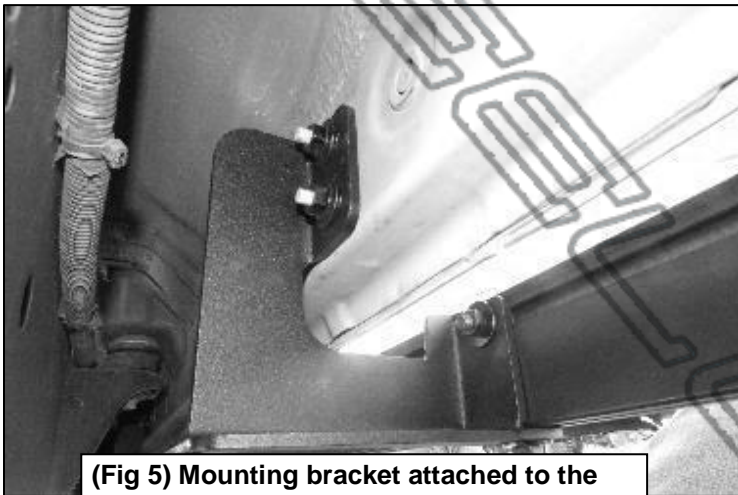

(Fig 5) Mounting bracket attached to the rear mounting location

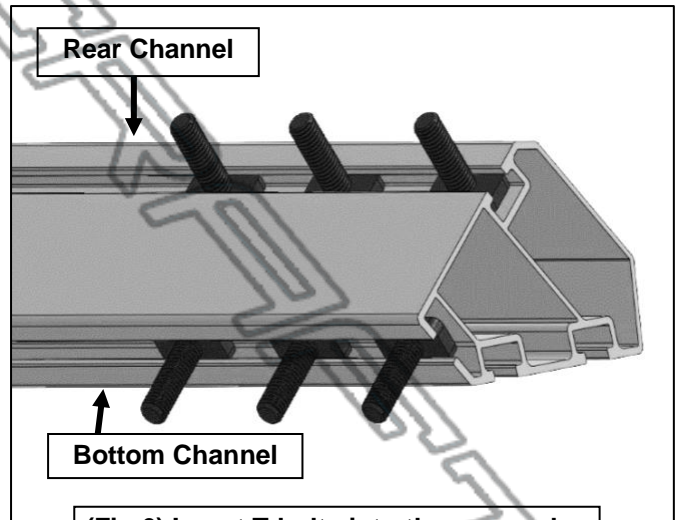

(Fig 6) Insert T-bolts into the rear and bottom channels on the universal mounting tube.

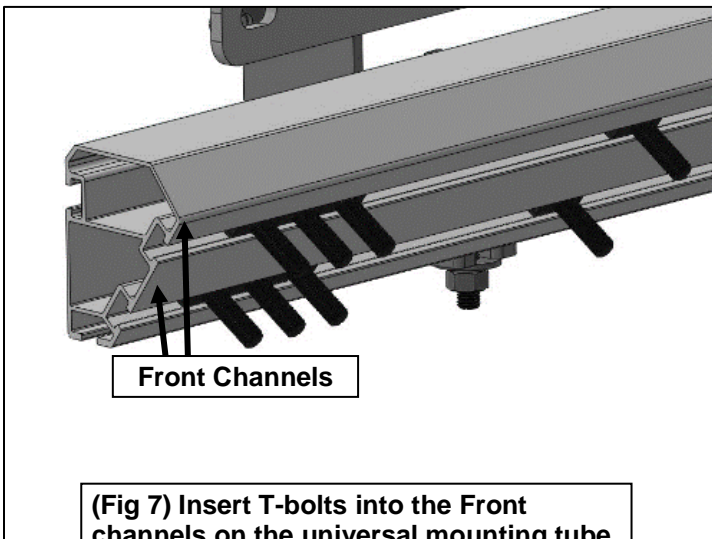

(Fig 7) Insert T-bolts into the Front channels on the universal mounting tube.

Passenger/Right Side Installation Pictured

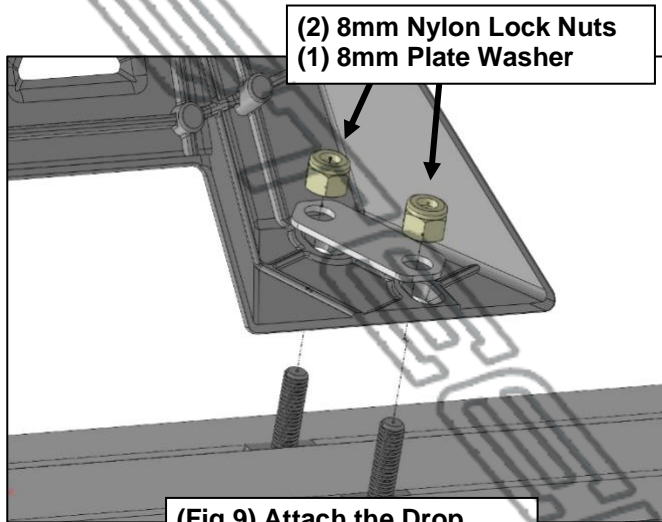

(Fig 9) Attach the Drop Steps to the 8mm T-bolts.

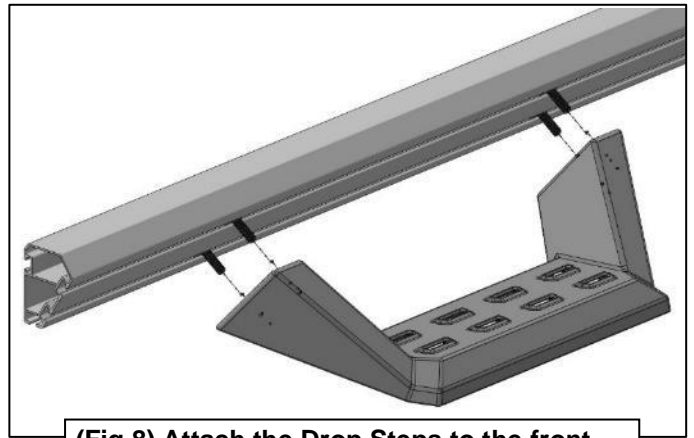

(Fig 8) Attach the Drop Steps to the front channels of the Universal Mounting Tube.

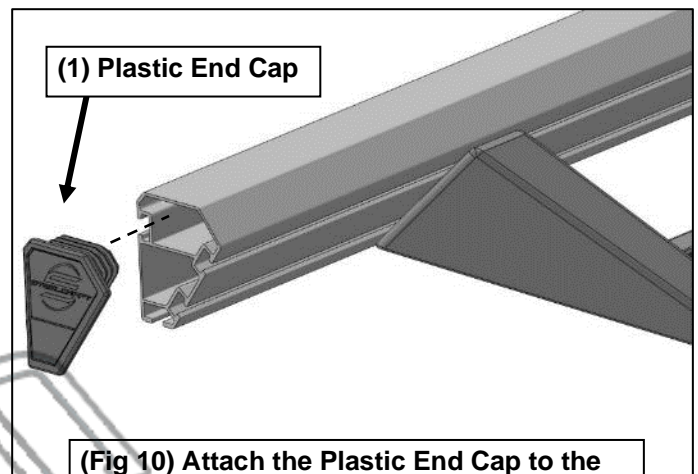

(Fig 10) Attach the Plastic End Cap to the end of the Universal Mounting Tube.

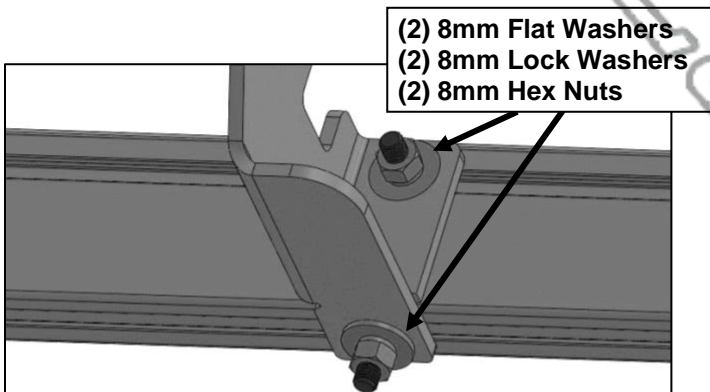

(Fig 11) Attach the Universal Mounting Tube to the Mounting Brackets.

