

**ELEVATION FRONT BUMPER  
2019-24 DODGE RAM 2500-5500**

**PARTS LIST:**

1	Elevation Front Bumper Assembly	2	12mm-1.75mm x 90mm Hex Bolts
2	Frame Mounting Brackets	8	12-1.75mm x 50mm Hex Bolts
1	Driver/left Round Fog Light Mount	20	12mm x 37mm x 3mm Flat Washers
1	Passenger/right Round Fog Light Mount	10	12mm Nylon Lock Nuts
1	Driver/left Fog Light Block Off	6	6mm x 25mm Hex Bolts
1	Passenger/right Fog Light Block Off	12	6mm x 22mm x 2mm Flat Washers
2	2mm Slide in Shims for Tow Hook	6	6mm Nylon Lock Nuts
2	3mm Slide in Shims for Tow Hook	8	4mm x 20mm Socket Head Screws
6	15.5mm x 25mm x 2mm Foam Washers	12	4mm Self Tapping Screws
6	Sensor Retaining Caps	16	4mm x 8.85mm x .8mm Flat Washers
6	20mm x 2mm Foam spacers	8	4mm Lock Washers
6	Sensor Hole Plugs	8	4mm Hex Nuts
2	Plastic Plugs for license plate mount	1	2.5mm Allen Wrench
1	Sensor Cover kit	1	4mm Allen Wrench

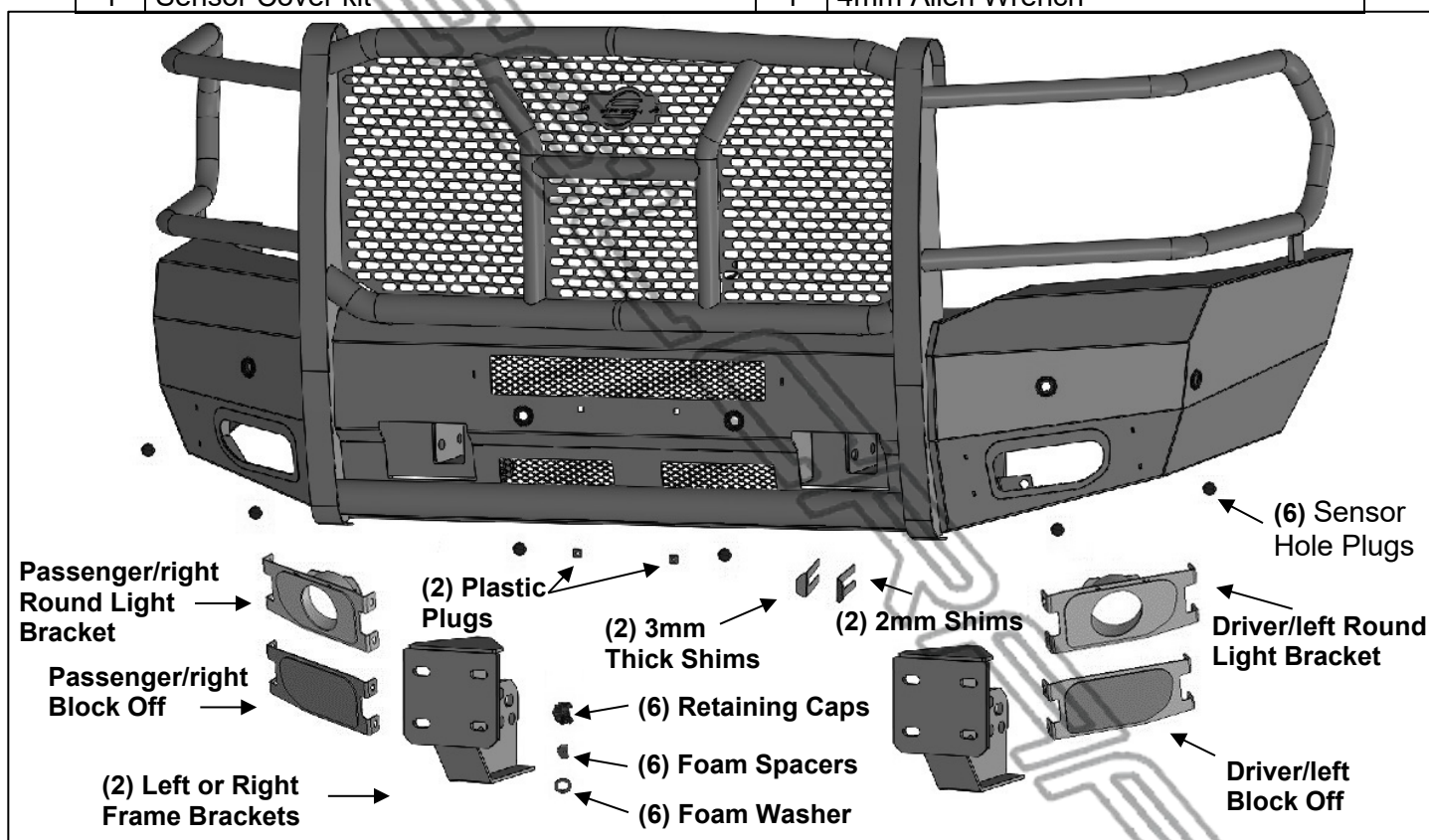

**PROCEDURE:**

- 1. REMOVE CONTENTS FROM BOX. VERIFY ALL PARTS ARE PRESENT. READ INSTRUCTIONS CAREFULLY BEFORE STARTING INSTALLATION. BUMPER IS HEAVY, ASSISTANCE IS HIGHLY RECOMMENDED. CUTTING MAY BE REQUIRED.**
- Remove the license plate. On models with bumper mounted sensors and/or fog lights, unplug the wiring harness leading to the front bumper. Move the wiring harnesses out of the way.
- Temporarily remove the tow hooks and hardware, **(Figure 1)**.
- Locate the factory bumper bolts attaching the inner bumper brackets to the end of the frame, **(Figure 1)**. With assistance, remove the (2) long hex bolts per side to remove the bumper assembly, **(Figure 2)**. **WARNING!** Assistance is required to hold the bumper in place during hardware removal to prevent the bumper from falling.

**ELEVATION FRONT BUMPER  
2019-24 DODGE RAM 2500-5500**

5. Remove the lower frame extension from the driver/left side of the frame, **(Figure 2)**. **NOTE:** Lower frame extension cannot be reinstalled.
6. Select (1) Frame Bracket. Line up the holes in the Bracket with the outside of the driver/left side of the frame. Reuse the (2) factory long hex bolts to attach the Bracket to the end of the frame, **(Figure 3)**. Reuse the (2) hex bolts from the lower frame extension, **(Figure 2)**, to attach the lower mount on the Bracket to the side of the frame. **NOTE:** For 45-5500 models in addition to step 5 & 6 use provided (1) 12-1.75 x 90mm hex bolt to insert into either upper bracket holes depending on factory hole locations.
7. Repeat **Steps 5 & 6** to attach the passenger/right side Mounting Bracket.
8. Carefully remove both fog light assemblies, all sensors and the wiring harness from the back of the OE bumper, **(Figure 4)**. Note location of each sensor for correct reinstallation.

**Models without bumper sensors:**

- a. Select the included (6) Sensor Hole Plugs.
- b. From in front of the bumper, push plugs into sensor mounting holes, **(Figure 5)**.

**Models with bumper mounted sensors:**

- a. Select the driver/left outer sensor. Remove the seal from the end of the sensor, **(Figure 6)**. Replace the seal with the included Foam Washer.
  - b. Push the sensor into the matching mounting socket in the back of the Bumper.
  - c. Apply (1) Foam Washer to the plug end of the sensor, **(Figure 7)**.
  - d. Secure the sensor to the socket with (1) Sensor Retaining Cap, **(Figure 7)**.
  - e. Move to the next sensor location. Repeat previous Steps to install the next sensor as you go across the Bumper.
  - f. **Optional:** Secure each sensor to the sensor sleeve with (2) 4mm Self Tapping Screws. **IMPORTANT:** Sensors fit snug in sockets. The 4mm Screws are used to apply slight pressure to lock the sensors in place. Tighten both screws evenly until they touch the sensor body only. Do not overtighten screws or damage to sensors will result.
  - g. Reinstall the factory wiring harness. **NOTE:** It may be necessary to remove some of the outer wiring cover to extend the reach of the harness to the sensors.
  - h. Secure harness to the Bumper as required.
9. Select the (2) factory tow hooks. Reuse the factory tow hook hardware to attach the tow hooks to the mounts in the Front Bumper. Insert the included Thick and/or Thin Shims as needed along the sides of the tow hook before tightening hardware, **(Figures 8 & 9)**.
  10. With assistance, position the Bumper assembly up to the (2) Frame Brackets. **WARNING:** To avoid possible injury or damage to the vehicle, do not proceed until the Bumper is fully and safely supported. Attach the Bumper to the Frame Brackets with (8) 12mm x 50mm Hex Bolts, (16) 12mm Flat Washers and (8) 12mm Nylon Lock Nuts, **(Figures 10 & 11)**. Snug but do not fully tighten hardware.
  11. Level and adjust the Bumper to the vehicle and tighten all hardware.
  12. On models with fog lights, determine style of fog light.

**Models equipped with rectangular fog lights:**

- a. Select the driver/left fog light assembly. Attach the assembly to the (3) mounting tabs on the back of the Bumper with the included (3) 6mm Bolts, (6) 6mm Flat Washers and (3) 6mm Nylon Lock Nuts, **(Figures 12 & 13)**. Repeat this Step to attach the passenger/right fog light assembly.
- b. Plug in the fog light harness to the lights and secure it to the Bumper.

**Models equipped with round fog lights:**

- a. Remove driver/left fog light mounting bracket from back of Bumper, **(Figure 12)**.
- b. Remove fog light from outer housing. Attach light to Mounting Bracket with (4) 4mm x 20mm Long Screws, (8) 4mm Flat Washers, (4) 4mm Lock Washers and (4) 4mm Hex Nuts, **(Figure 14)**.
- c. Reuse hardware to attach the driver/left Round Fog Light Bracket to the back of the Bumper, **(Figure 15)**.
- d. Repeat previous Steps to attach the passenger/right fog light.
- e. Plug in the fog light harness to the lights and secure it to the Bumper.

**Models without fog lights.**

- a. Remove the preinstalled driver/left rectangular fog light mount insert from the back of the HD Bumper, **(Figure 12)**.

**ELEVATION FRONT BUMPER  
2019-24 DODGE RAM 2500-5500**

- b. Select the driver/left Block Off. Reuse the hardware to attach the Block Off to the tabs on the back of the Bumper, **(Figure 15)**.
  - c. Repeat previous Steps to install the passenger/right Block Off.
13. Install (2) Plastic License Plate Plugs into the holes in the Bumper, **(Figure 16)**. Reuse factory screws to attach license plate to Plugs.
14. On models equipped with forward facing camera, remove the screen from the Bumper, **(Figure 16)**.
15. Do periodic inspections to the installation to make sure that all hardware is secure and tight.

**To protect your investment**, do not use any type of polish or wax that may contain abrasives that could damage the finish. Mild soap may be used to clean the Bumper Assembly.

**Driver Side Installation Pictured**

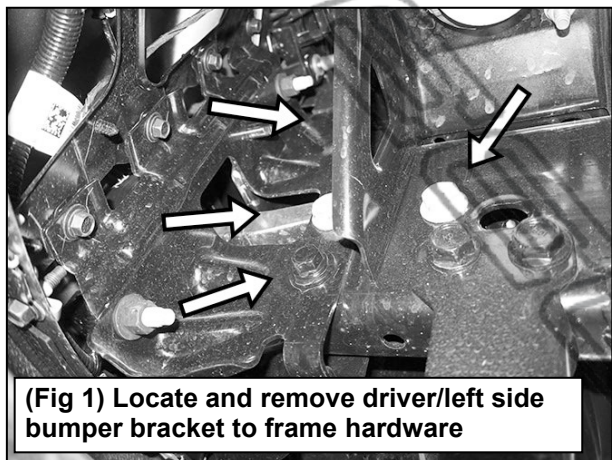

Optional holes for 45-5500 trucks if applicable use (1) 90mm Bolt per Frame Bracket

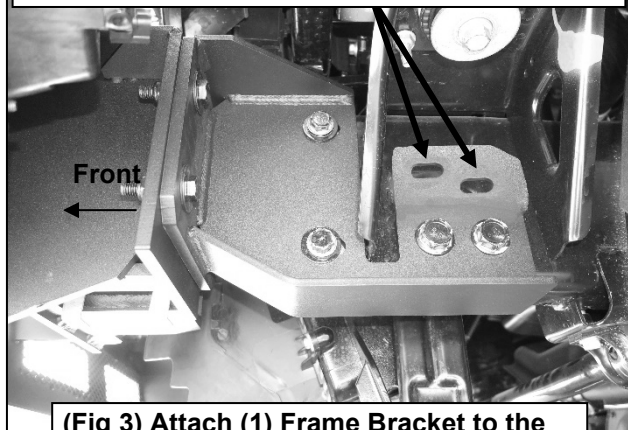

**WARNING!** To avoid possible injury or damage to vehicle, do not remove bumper bolts unless the bumper is properly supported on blocks or stands or it may fall.

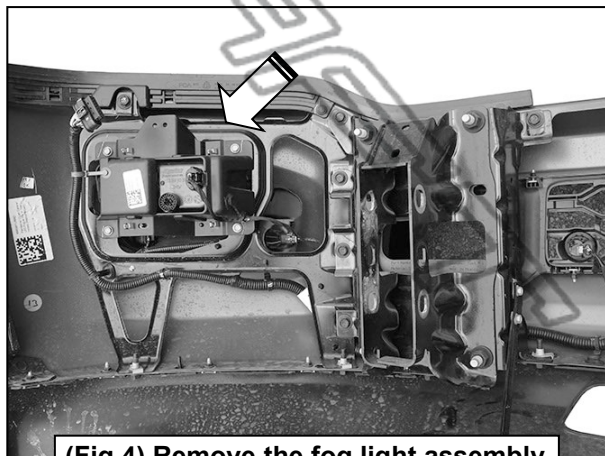
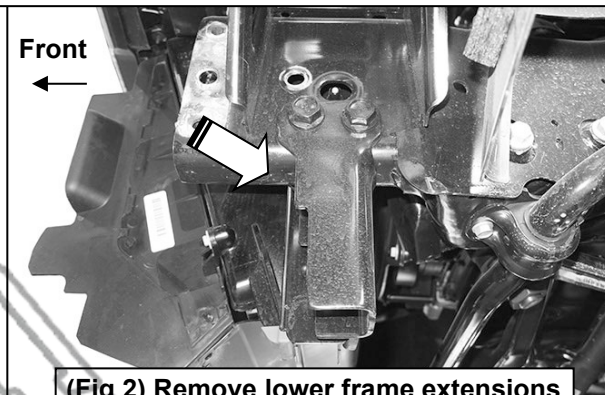

Driver Side Installation Pictured

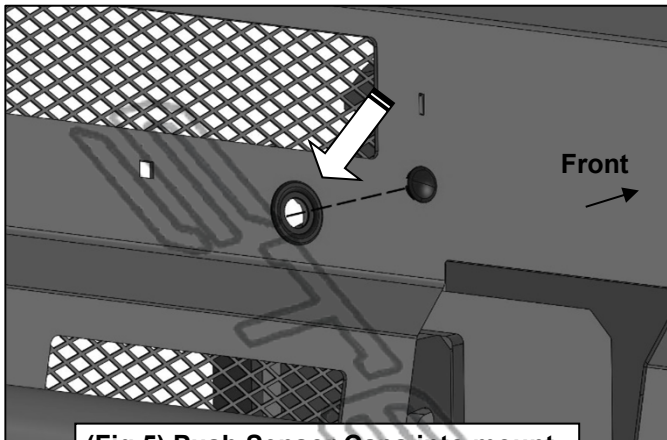

(Fig 5) Push Sensor Caps into mount

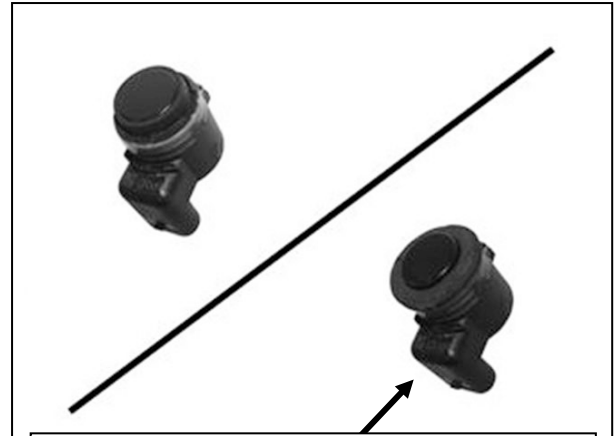

(Fig 6) Remove silicone seal from sensor.  
Slide Foam Washer over end of sensor

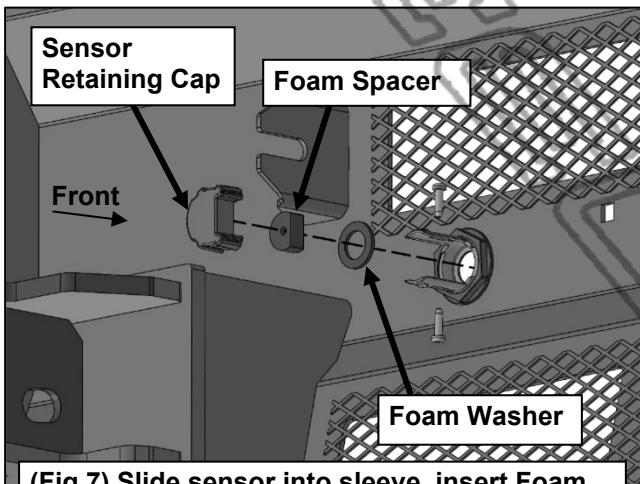

(Fig 7) Slide sensor into sleeve, insert Foam Washer and Clip to lock sensor in sleeve

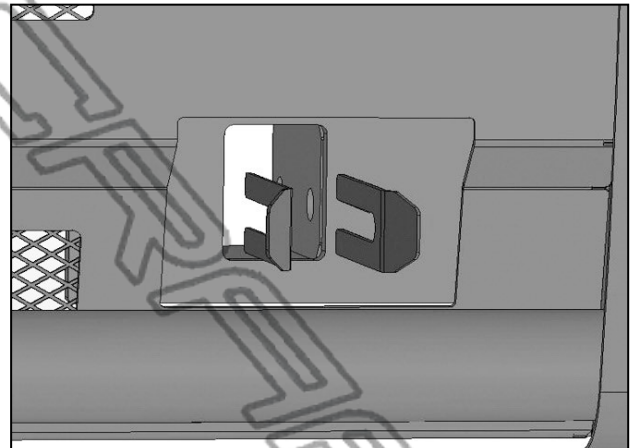

(Fig 8) Slide tow hook into opening in Bumper.  
Insert Thick or Thin Shim along one or both sides of tow hook as needed to adjust fit of tow hook to mount in Bumper

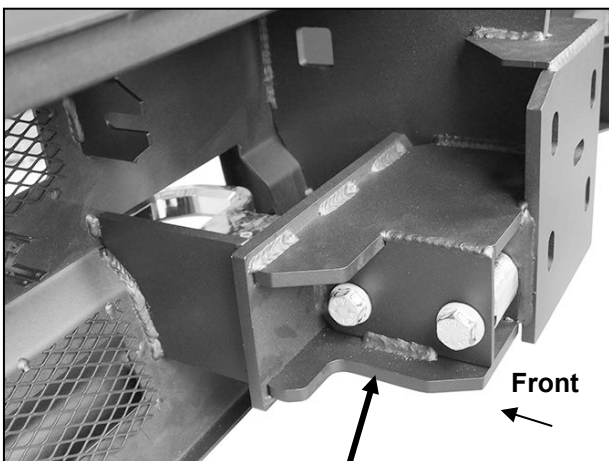

(Fig 9) Reuse factory hardware to attach tow hook to mounts in Bumper (passenger/right side pictured from back of Bumper)

**WARNING!** Do not crawl under bumper unless it is properly supported on blocks or stands or it may fall.

Driver Side Installation Pictured

- (4) 12mm x 50mm Hex Bolts
- (8) 12mm Flat Washers
- (4) 12mm Nylon Lock Nuts

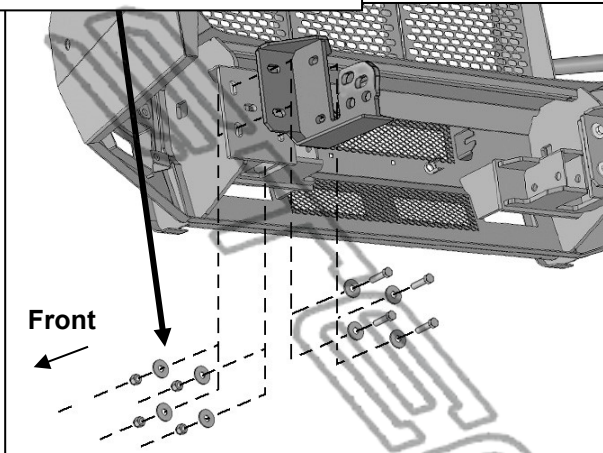

(Fig 10) Attach Bumper to driver/left Bracket

**WARNING!** Do not crawl under bumper unless it is properly supported on blocks or stands or the bumper may fall.

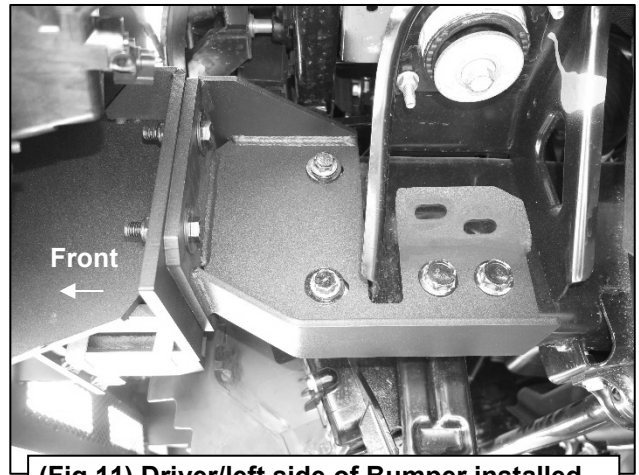

(Fig 11) Driver/left side of Bumper installed

- (3) 6mm x 25mm Hex Bolts
- (6) 6mm Flat Washers
- (3) 6mm Nylon Lock Nuts

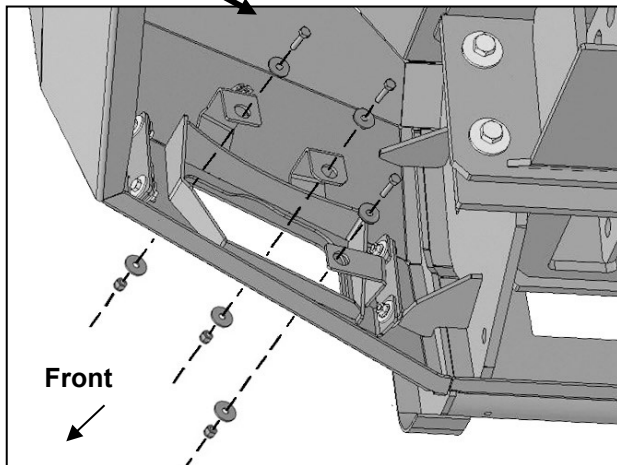

(Fig 12) Attach rectangular fog light assembly to mounts on back of Bumper

- (3) 6mm x 25mm Hex Bolts
- (6) 6mm Flat Washers
- (3) 6mm Nylon Lock Nuts

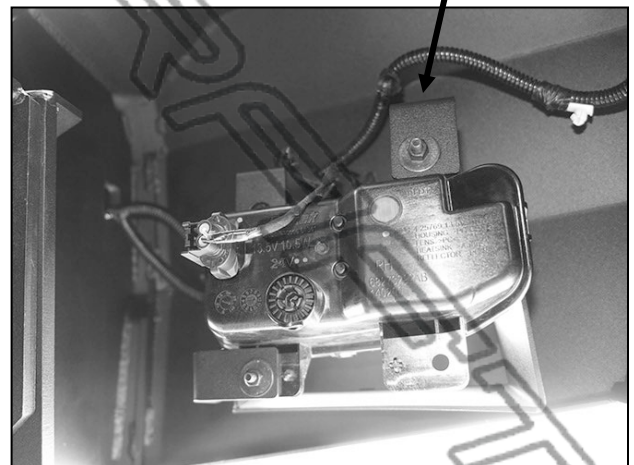

(Fig 13) Attach fog light to mounting tabs on back of Bumper (passenger/right side pictured)

Driver Side Installation Pictured

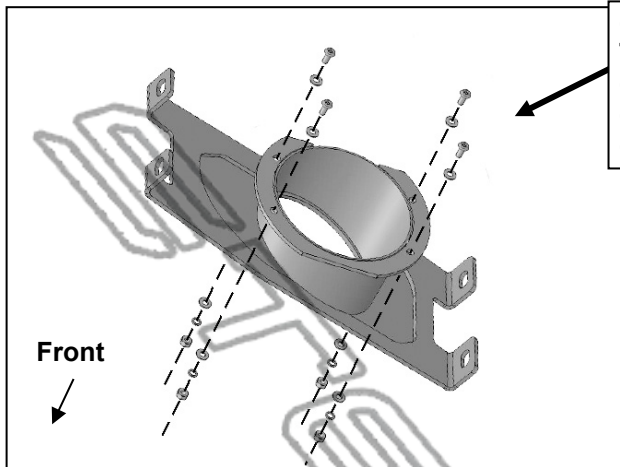

- (4) 4mm x 20mm Self Tapping Screws
- (8) 4mm Flat Washers
- (4) 4mm Lock Washers
- (4) 4mm Hex Nuts

(Fig 14) Attach round fog light to driver/left Mounting Bracket

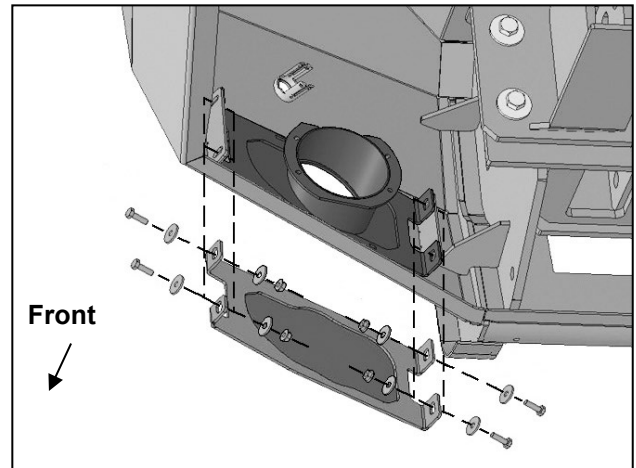

(Fig 15) Reuse hardware to attach Round Fog Light Bracket assembly or Block Off to the tabs on the back of the Bumper

Use 4mm Allen Wrench to remove screen on models with grille mounted camera

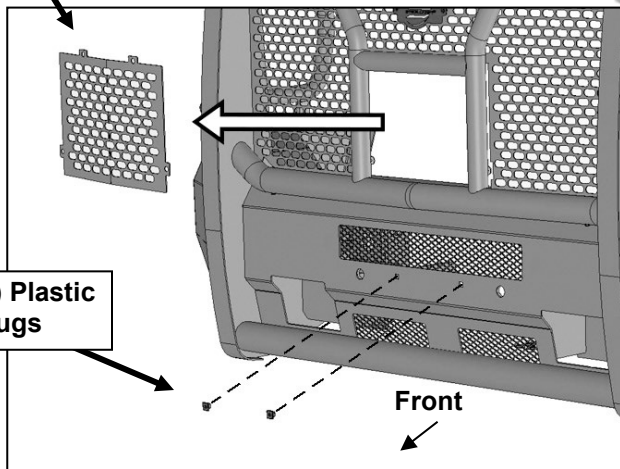

(2) Plastic Plugs

(Fig 16) Push Plastic Plugs into Bumper for license plate



Complete Installation