

**ELEVATION FRONT BUMPER  
2024 CHEVY SILVERADO 25-3500**

**PARTS LIST:**

1	Elevation Front Bumper Assembly	4	12mm x 130mm Hex Bolts
1	Driver/left Mounting Bracket	28	12mm x 32mm OD x 3mm Flat Washers
1	Passenger/right Mounting Bracket	14	12mm Nylon Lock Nuts
2	Driver/left Support Brackets	10	12mm x 50mm Hex Bolts
2	Passenger/right Support Brackets	4	10mm x 35mm Double Bolt Plates
2	Shutter Relocation "L" Brackets	9	10mm x 40mm Hex Bolts
3	Sensor Wiring Harness Extensions	8	10mm Lock Washers
2	Plastic Plugs for License Plate	8	10mm x 27mm OD x 3mm Flat Washers
1	Sensor Cover Kit	10	10mm x 34mm OD x 3mm Flat Washers
4	Plastic Sensor Hole Plugs	9	10mm Nylon Lock Nuts
4	Sensor Retaining Caps	10	6mm x 20mm Hex Bolts
4	Foam Sensor Sealing Washers	20	6mm x 18mm OD x 1.6mm Flat Washers
4	20mm x 2mm Foam Spacers	10	6mm Nylon Lock Nuts
1	Engine Block Heater Bracket	8	4mm Self-Tapping Screws (Optional)
2	3mm Horseshoe Tow Hook Shim	1	4mm Allen Wrench
2	2mm Horseshoe Tow Hook Shim		

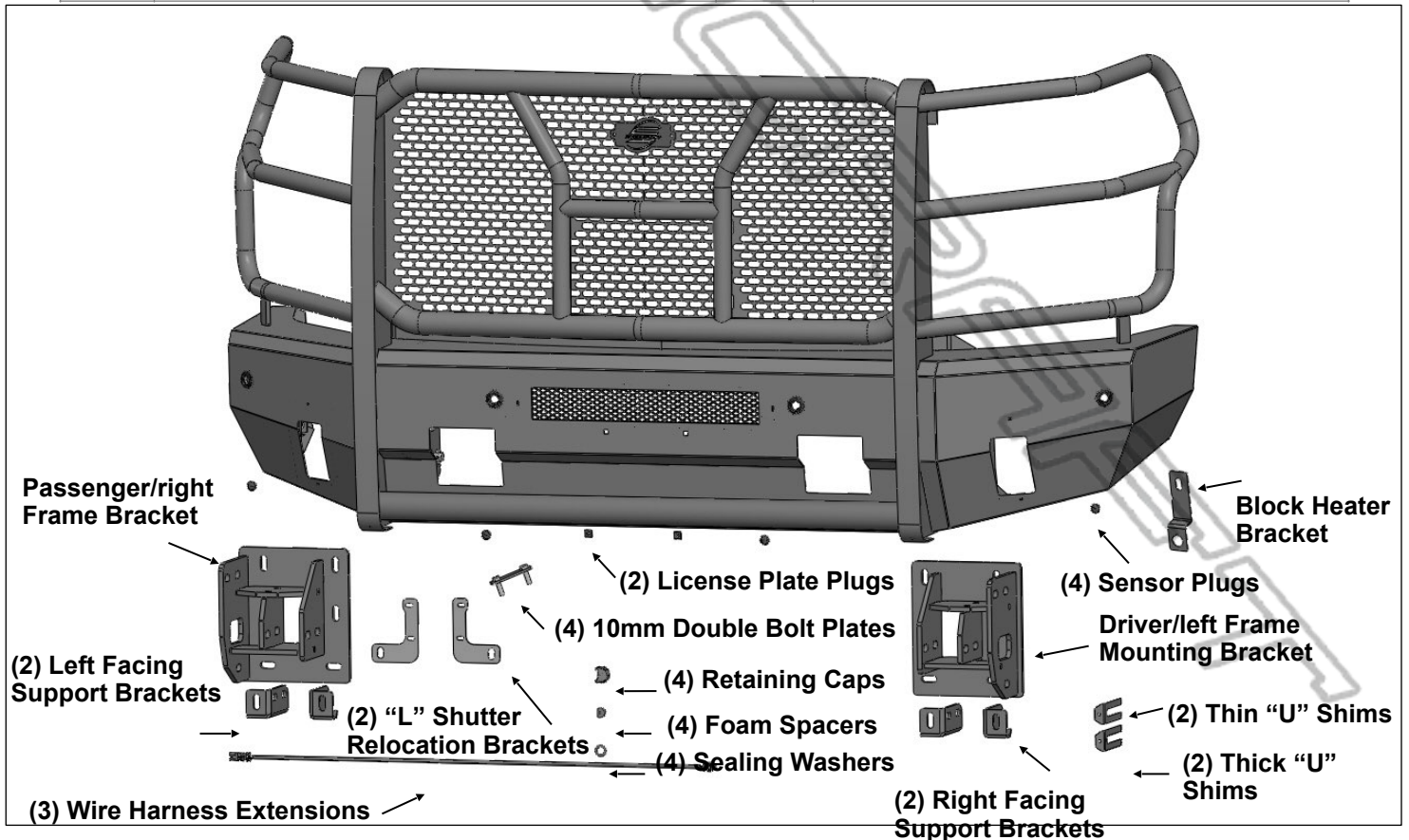

**PROCEDURE:**

**REMOVE CONTENTS FROM BOX. VERIFY ALL PARTS ARE PRESENT. READ INSTRUCTIONS CAREFULLY BEFORE STARTING INSTALLATION. BUMPER IS HEAVY, ASSISTANCE IS HIGHLY RECOMMENDED TO AVOID POSSIBLE INJURY OR DAMAGE TO THE VEHICLE.**

1. Start installation at the driver/left wheel opening. Remove the hardware attaching the fender liner to the front of the fender and the end of the plastic body panel, **(Figure 1)**. Carefully pull the fender flare out to release the clips attaching it to the body panel, (fascia), and end of the fender, **(Figure 2)**. Only release the forward end of the flare, it is not necessary to remove the flare. Remove the screws attaching the end of the fascia panel to the front fender, **(Figure 3)**. Repeat this Step to release the passenger/right end of the fascia from the fender. Pull along the center of the fascia to release the remainder of the clips and move the plastic panel to a clean surface, **(Figure 4)**.
2. Open the hood and temporarily remove the hood release handle and plastic cover from the top of the grille and radiator, **(Figure 5)**. Remove the hardware attaching the grille and pull it straight out from the vehicle. On models with grille mounted camera, unplug harness leading to the camera and remove the grille, **(Figures 6 & 7)**.
3. Unplug any wiring harnesses leading to the front bumper, **(Figure 8)**. Move all harnesses away from bumper. Remove the license plate and bracket if equipped.
4. Remove the hardware at each end of the bumper attaching the bumper supports to each side of the frame, **(Figure 9)**.
5. Place blocks or jack stands under the front bumper to support it during mounting bolt removal. Once the bumper has been safely supported, from above the bumper, remove the (2) factory upper and lower bumper bolts from each side, **(Figure 10)**. **WARNING!** Assistance is required to hold the bumper in place during bolt removal to prevent the bumper from falling. Remove the bumper assembly.
6. Remove the factory bumper brackets and tow hooks, (if equipped), from the end of frame, **(Figure 11 & 13)**. On models with lower radiator shutter assembly, unplug and remove the assembly, **(Figure 12)**.
7. Select the driver/left Frame Mounting Bracket, **(Figure 14)**. Attach the Bracket to the mounting plate on the end of the frame with the included (4) 10mm x 40mm Hex Bolts, (4) 10mm Lock Washers, and (4) 10mm x 34mm large Flat Washers, **(Figures 14 & 15)**. Do not tighten hardware at this time.
8. Next, select (1) 10mm Double Bolt Plate and (1) Left Facing Lower Support Bracket, **(Figure 16)**. Insert the Bolt Plate up into the open end of the frame and through the holes in the outside of the frame. Attach the Left Facing Support Bracket to the Double Bolt Plate with (2) 10mm Flat Washers and (2) 10mm Nylon Lock Nuts, **(Figure 16 & 18)**. Attach the front of the Support Bracket to the back of the Mounting Bracket with (1) 12mm x 50mm Hex Bolt, (2) 12mm Flat Washers and (1) 12mm Nylon Lock Nut, **(Figure 17)**. Do not tighten at this time. Repeat this Step to attach Right Facing Support Bracket to the inner side of the frame and back of the Mounting Bracket, **(Figure 16, 17 & 19)**.
9. On models equipped with lower radiator shutter system, remove shutter assembly from outer plastic housing, **(Figure 20)**. Select (1) "L" Relocation Bracket. Use the previously installed (1) 12mm x 50mm Hex Bolt, (2) 12mm Flat Washers and (1) 12mm Nylon Lock Nut to attach the Bracket to the front of the Frame Bracket and Inner Support Bracket, **(Figure 21)**. Repeat this Step to attach the remaining "L" Bracket. Attach the shutter assembly to the "L" Brackets with the included (4) 6mm x 20mm Hex Bolts, (8) 6mm Flat Washers and (4) 6mm Nylon Lock Nuts. Do not overtighten the 6mm hardware or damage to the plastic shutter assembly may result. Plug wiring harness into shutter assembly
10. Reinstall fascia, grille and top cover removed in **Steps 1—3**.
11. Sensors must be installed in Bumper, (if equipped), before installing Bumper Assembly.

**Models without bumper parking sensors:**

- a. Select the included (4) Plastic Sensor Plugs.
- b. From the front of the bumper, push the included Plastic Plugs into the mounts, **(Figure 22)**.

**Models with bumper mounted parking sensors:**

- a. Disassemble the front bumper to access the sensors and wiring harness, **(Figure 23)**. Unplug and remove sensors and wiring harness from factory bumper.

**ELEVATION FRONT BUMPER  
2024 CHEVY SILVERADO 25-3500**

- b. Remove the OE silicone seal from the end of the sensors. Select the included larger (1) Foam Sensor Seal and peel off the adhesive backing. Slide the included Sensor Seal over front of a sensor, **(Figure 24)**.
  - c. Insert sensor with Seal into sensor mount on back of bumper until it clicks into position, **(Figure 25)**.
  - d. Select the included (1) Foam Spacer and peel off the adhesive backing. Place Foam Spacer into (1) Sensor Retainer Cap. Push Sensor Retaining Cap and Foam Spacer onto sensor mount and lock into mounting holes, **(Figure 25)**.
  - e. Repeat previous Steps to install remaining sensors.
12. With assistance, position the Bumper Assembly up to and over the Brackets. Temporarily support the weight of the Bumper. **WARNING:** To avoid possible injury or damage to the vehicle, do not proceed until the Bumper is fully and safely supported.
  13. Line up the driver/left mounting plate on the inside of the Bumper with the Frame Bracket. Attach the Bumper to the Bracket with the included (3) 12mm x 50mm Hex Bolts, (6) 12mm Flat Washers and (3) 12mm Nylon Lock Nuts, **(Figures 26 & 27)**. Do not fully tighten hardware at this time. Repeat this Step to attach the passenger side mounting plate to the Frame Bracket.
  14. Level and adjust the bumper and fully tighten all hardware.
  15. Select (1) tow hook if equipped. Flip the tow hook upside-down and insert it into the opening in the Bumper and into the Frame Bracket, **(Figure 28)**. Insert the included (2) 12mm x 130mm Hex Bolts, (4) 12mm Flat Washers and (2) 12mm Nylon Lock Nuts through the Bracket and tow hook. Use the included Thick or Thin "U" Shims to adjust fit side to side between tow hook and Bracket. Once properly adjusted, fully tighten the tow hook hardware. Repeat this Step to install the passenger/right tow hook.
  16. **Models with fog lights:**
    - a. Remove the fog lights from the factory bumper. Brackets may need to be removed to gain proper access **(Figure 23)**.
    - b. Attach the driver/left fog light to the Bumper with the included (3) 6mm x 20mm Hex Bolts, (6) 6mm Flat Washers and (3) 6mm Nylon Lock Nuts, **(Figure 29)**. Do not overtighten hardware or damage to the light may result.
    - c. Repeat the previous Steps to attach the passenger/right side fog light.
  17. Install the factory bumper wiring harness for sensors and fog lights as equipped, **(Figure 30)**. **NOTE:** (3) Wire Harness Extensions have been included to extend the factory harness to reach the sensors as needed. Plug harness into fog lights.
  18. Use the included (2) push-in Plastic License Plate Plugs to attach the front license plate, (if required), to the (2) holes in the front Bumper, **(Figure 31)**.
  19. Optional: Trim fender liners to match new bumper height, **(Figure 32)**.
  20. Models with grille mounted camera, remove screen from center camera window of Bumper, **(Figure 33)**.
  21. Optional: Models with engine block heater; use universal Engine Block Heater Bracket to relocate the heater plug, **(Figure 34)**.
  22. Back of Bumper is equipped with mounting tabs for LED center light. Follow manufacturer's installation and wiring instructions for proper installation.
  23. Do periodic inspections to the installation to make sure that all hardware is secure and tight.

**To protect your investment,** Do not use any type of polish or wax that may contain abrasives that could damage the finish. Mild soap may be used to clean the Elevation Front Bumper assembly.

**Driver/left Side Pictured**

**Front**

**ELEVATION FRONT BUMPER  
2024 CHEVY SILVERADO 25-3500**



**(Fig 1) Release hardware attaching fender liner from plastic panel (fascia-see arrows)**

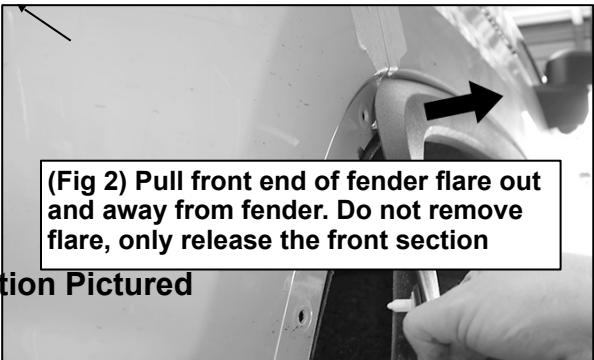
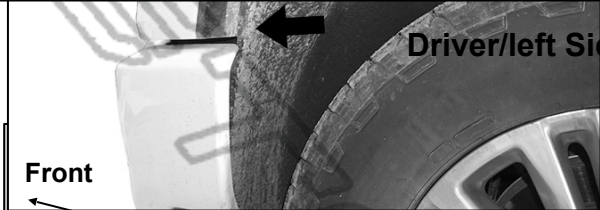

**(Fig 2) Pull front end of fender flare out and away from fender. Do not remove flare, only release the front section**



**(Fig 3) Remove screws attaching plastic fascia panel to front end of fender (arrow)**



**(Fig 4) Remove plastic fascia from top of bumper**

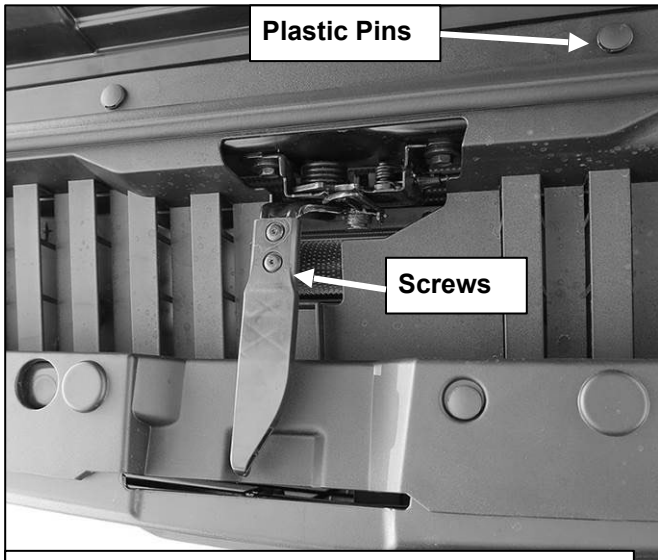

**(Fig 5) Remove hood handle and radiator cover**

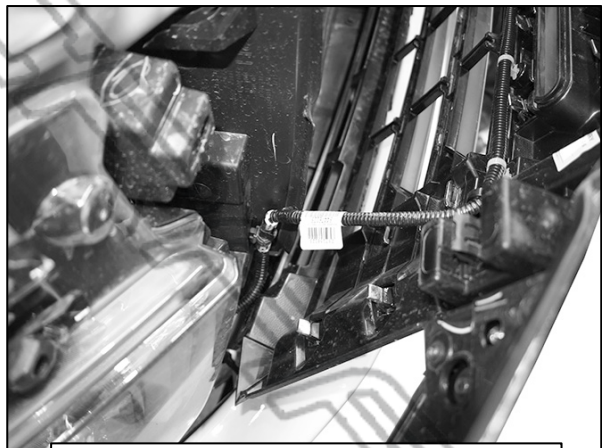

**(Fig 6) Disconnect harness to camera (if equipped) and remove grille**

**ELEVATION FRONT BUMPER  
2024 CHEVY SILVERADO 25-3500**



Driver/left Side Installation Pictured

**WARNING!** Do not crawl under bumper unless it is properly supported on blocks or stands or the bumper may fall.

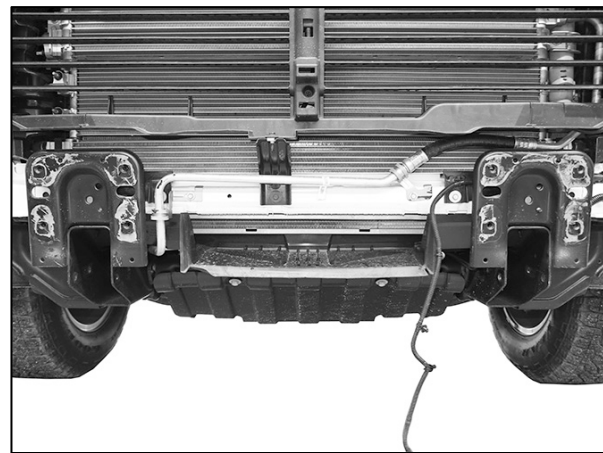
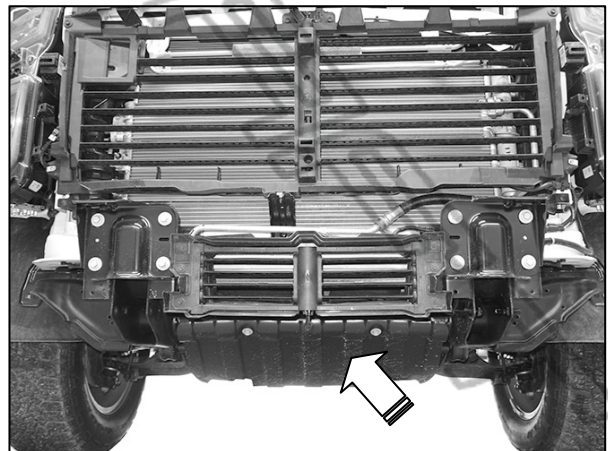
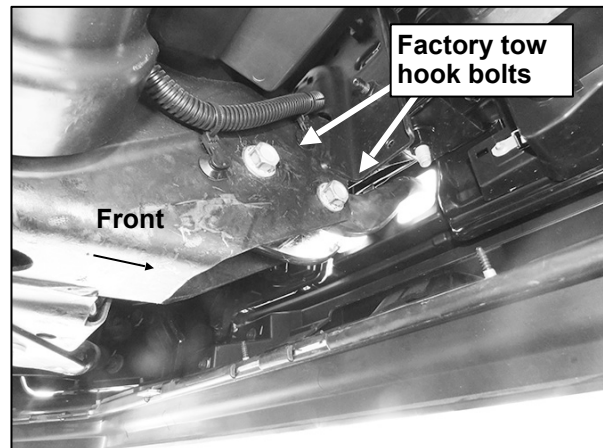
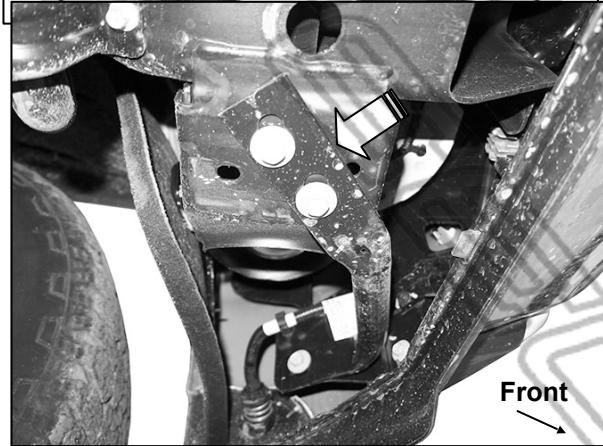

(Fig 13) Exposed vehicle frame with everything removed

Driver/left Side Installation Pictured

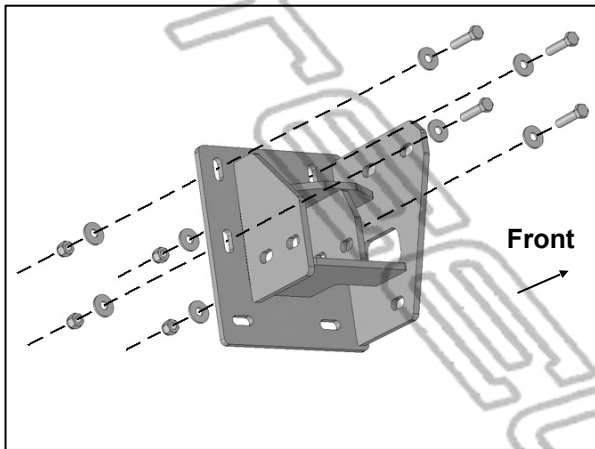

(Fig 14) Attach Driver/left Frame Bracket to end of frame

- (4) 10mm x 40mm Hex Bolts
- (4) 10mm Lock Washers
- (4) 10mm Flat Washers

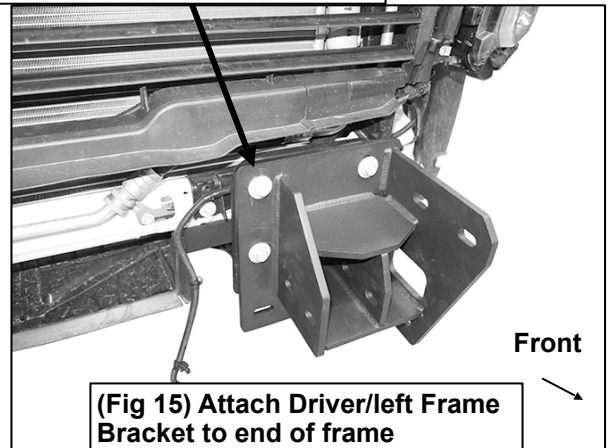

(Fig 15) Attach Driver/left Frame Bracket to end of frame

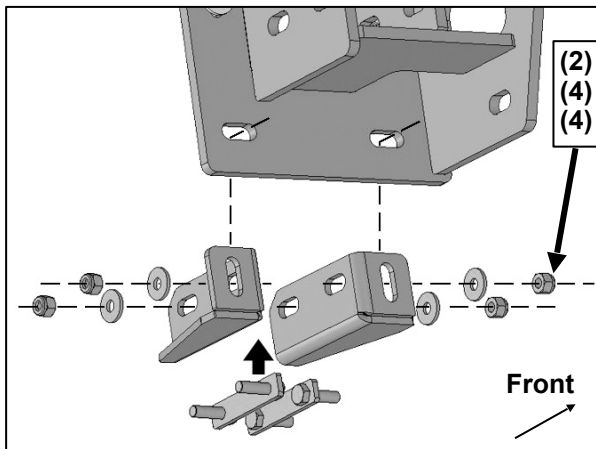

(Fig 16) Attach (1) Left Facing and (1) Right Facing Support Bracket to the sides of the frame

- (2) 10mm Double Bolt Plates
- (4) 10mm Flat Washers
- (4) 10mm Nylon Lock Nuts

- (2) 12mm x 50mm Hex Bolts
- (4) 12mm Flat Washers
- (2) 12mm Nylon Lock Nuts

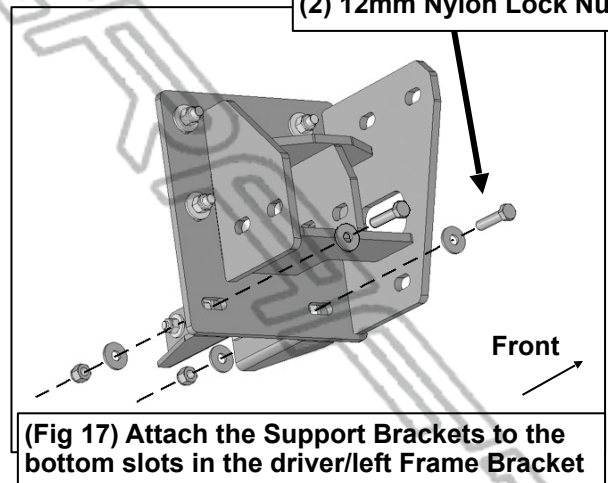

(Fig 17) Attach the Support Brackets to the bottom slots in the driver/left Frame Bracket

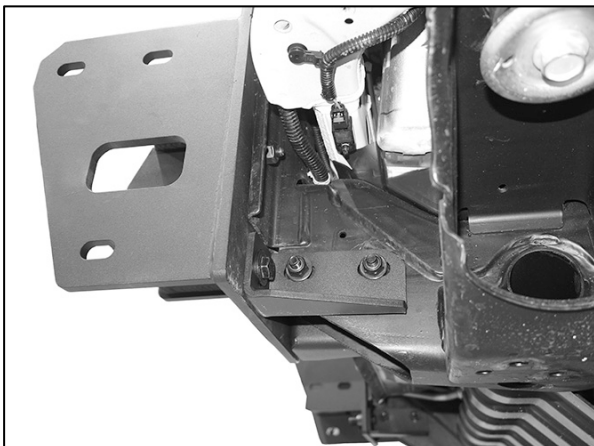

ELEVATION FRONT BUMPER  
2024 CHEVY SILVERADO 25-3500

Front

(Fig 18) Left facing Support Bracket installed



(Fig 19) Right facing Support Bracket installed

Driver/left Side Installation Pictured

- (2) 6mm x 20mm Hex Bolts
- (4) 6mm Flat Washers
- (2) 6mm Nylon Lock Nuts

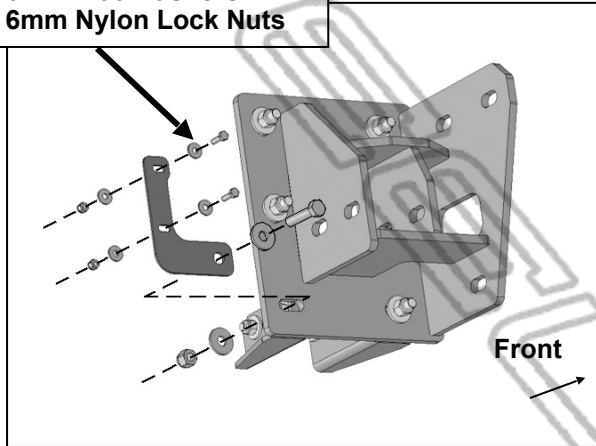

(Fig 21) Attach "L" Relocation Brackets to front of Frame Brackets. Attach shutter assembly, (if equipped), to front of Relocation Brackets



(Fig 20) Remove inner shutter assembly from plastic outer housing (if equipped)

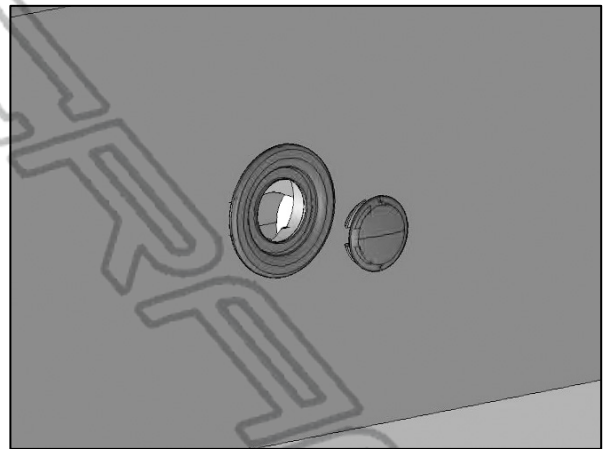

(Fig 22) Models without sensors, push Plastic Plugs into mounts on front of bumper

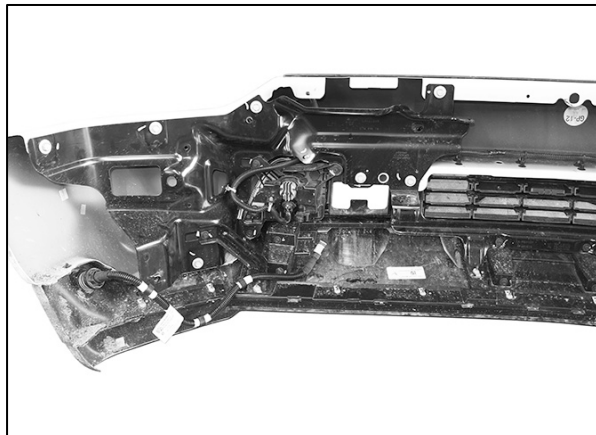

(Fig 23) Disassemble bumper and remove fog lights, sensors and wiring harness as equipped

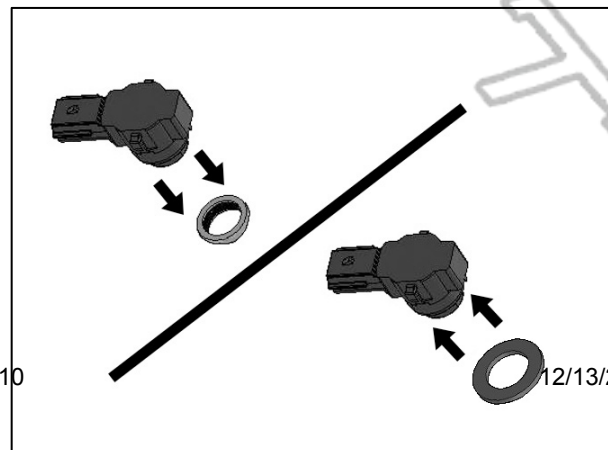

(Fig 24) Remove silicone seal from sensor.  
Slide large Seal over end of sensor (arrow)

Driver/left Side Installation Pictured

**WARNING!** Do not crawl under bumper unless it is properly supported on blocks or stands or the bumper may fall.

- (3) 12mm x 50mm Hex Bolts
- (6) 12mm Flat Washers
- (3) 12mm Nylon Lock Nuts

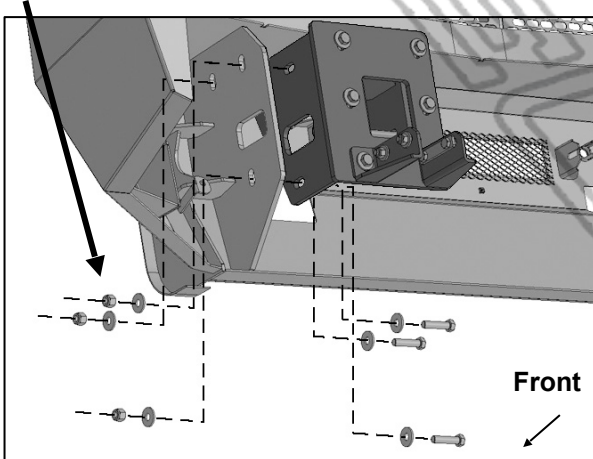

(Fig 26) Attach the Bumper to Frame Brackets

- (2) 12mm x 130mm Hex Bolts
- (4) 12mm Flat Washers
- (2) 12mm Nylon Lock Nuts

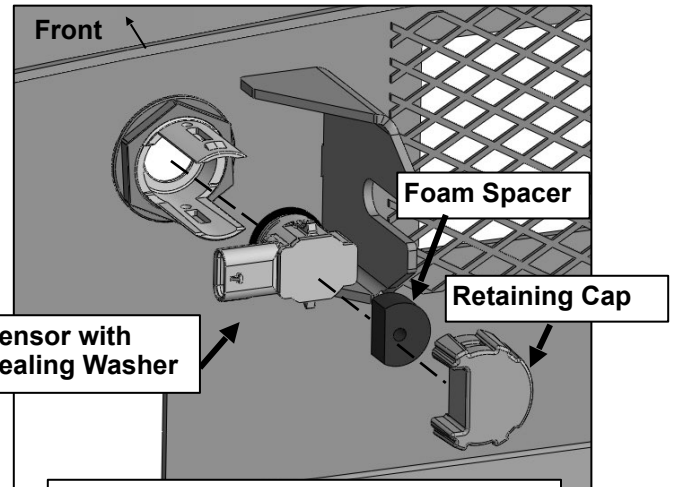
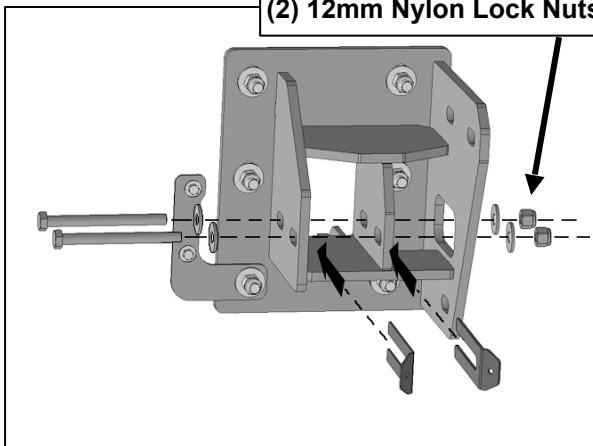

(Fig 25) Insert sensor with Sealing Washer into mount on back of Bumper

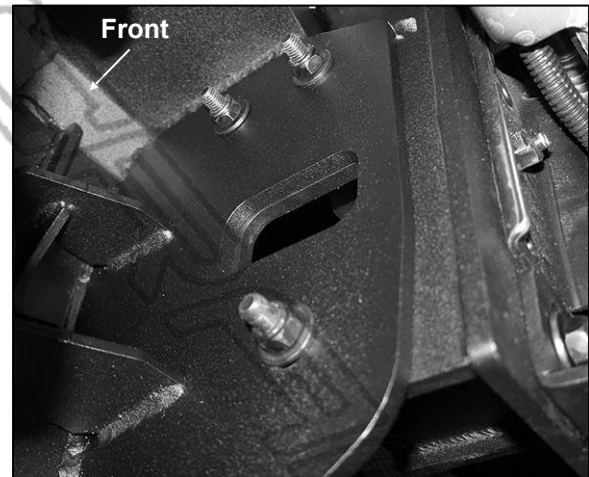

(Fig 27) Driver/left side of Bumper attached.

- (3) 6mm x 20mm Hex Bolts
- (6) 6mm Flat Washers
- (3) 6mm Nylon Lock Nuts



(Fig 28) Attach tow hook upside-down to inside of Frame Bracket. Use Thick or Thin "U" Shims to adjust side to side fit of tow hook to Bracket

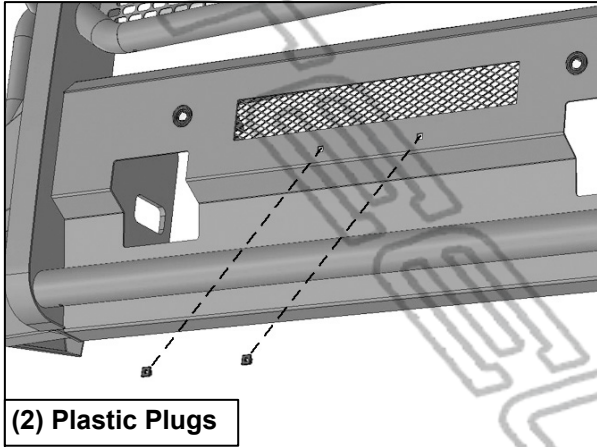

(2) Plastic Plugs

(Fig 31) Attach License Plate to Bumper

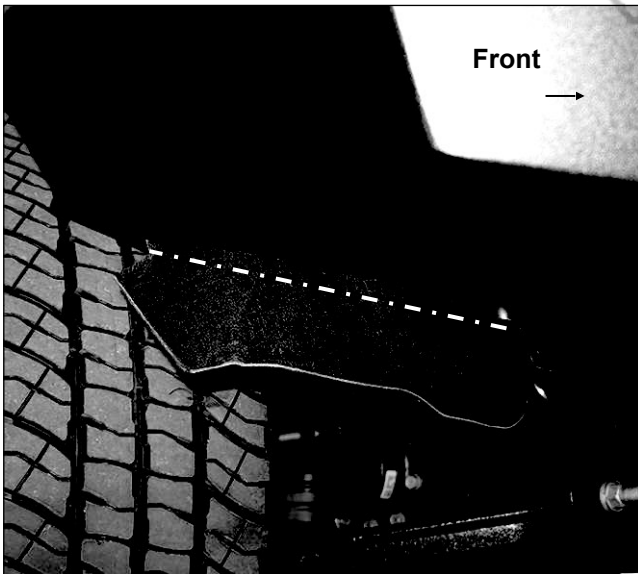

(Fig 32) Trim OE fender liner flush with bottom of bumper

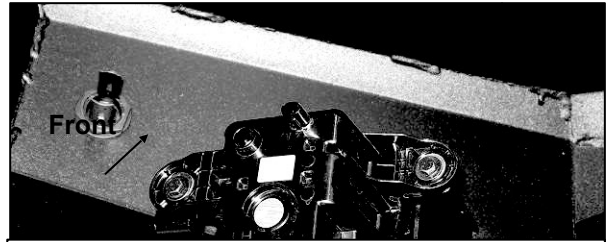

(Fig 29) Attach fog light to mounting tabs on back of Bumper

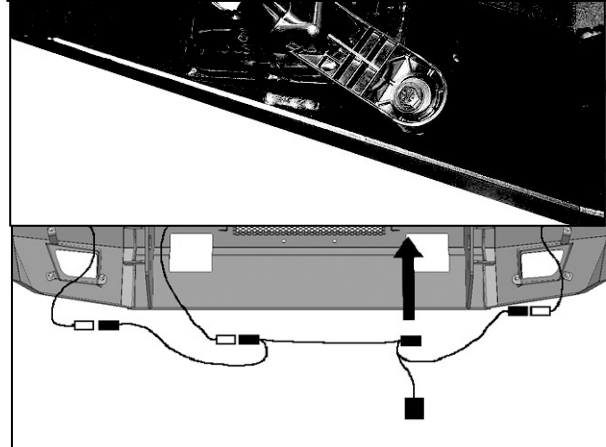

(Fig 30) Reinstall factory wiring harness over Bumper Brackets on back of Bumper. NOTE: Use the included (3) Wire Harness Extensions as necessary to reach the parking sensors

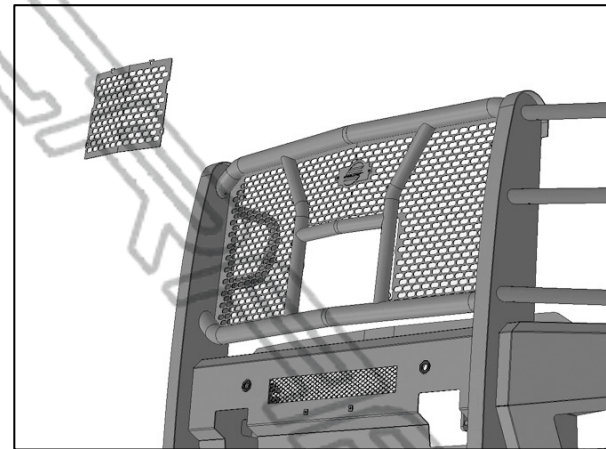

(Fig 33) Models with camera, remove screen covering camera window

**ELEVATION FRONT BUMPER  
2024 CHEVY SILVERADO 25-3500**

