

**PARTS LIST:**

1	Front Bumper Assembly	20	12mm x 32mm x 3mm Flat Washers
1	Driver/left Frame Bracket	12	12mm Lock Washers
1	Passenger/right Frame Bracket	8	12mm Hex Nuts
4	Frame Bracket "U" Spacer Plates	4	8-1.25mm x 25mm Hex Bolts
1	Driver/left LED "L" Bracket	2	8-1.25mm x 16mm Hex Bolts
1	Passenger/right LED "L" Bracket	10	8mm x 24mm Flat Washers
1	ACC Sensor Relocation Bracket	6	8mm Lock Washers
1	ACC Plastic Cover	4	8mm Hex Nuts
2	Plastic Plugs for license plate mount	2	6mm x 25mm Button Head Bolts
6	Sensor Retaining Caps	2	6mm x 18mm x 1.6 Flat Washers
6	20mm x 10mm Foam Spacers	2	6mm Lock Washers
6	15.5mm x 25mm x 2mm Foam Seals	2	6mm Flange Nuts
6	Plastic Sensor Hole Plugs	4	5mm x 16mm Button Head Bolts
2	Wiring Harness Extensions	4	5mm x 10mm Flat Washers
1	Sensor Cover Kit	4	5mm Lock Washers
2	12mm Double Nut Plates	4	5mm Hex Nuts
2	12-1.75mm x 170mm Hex Bolts	12	4mm Self Tapping Screws
10	12-1.75mm x 45mm Hex Bolts	1	4mm Wrench
		1	3mm Wrench

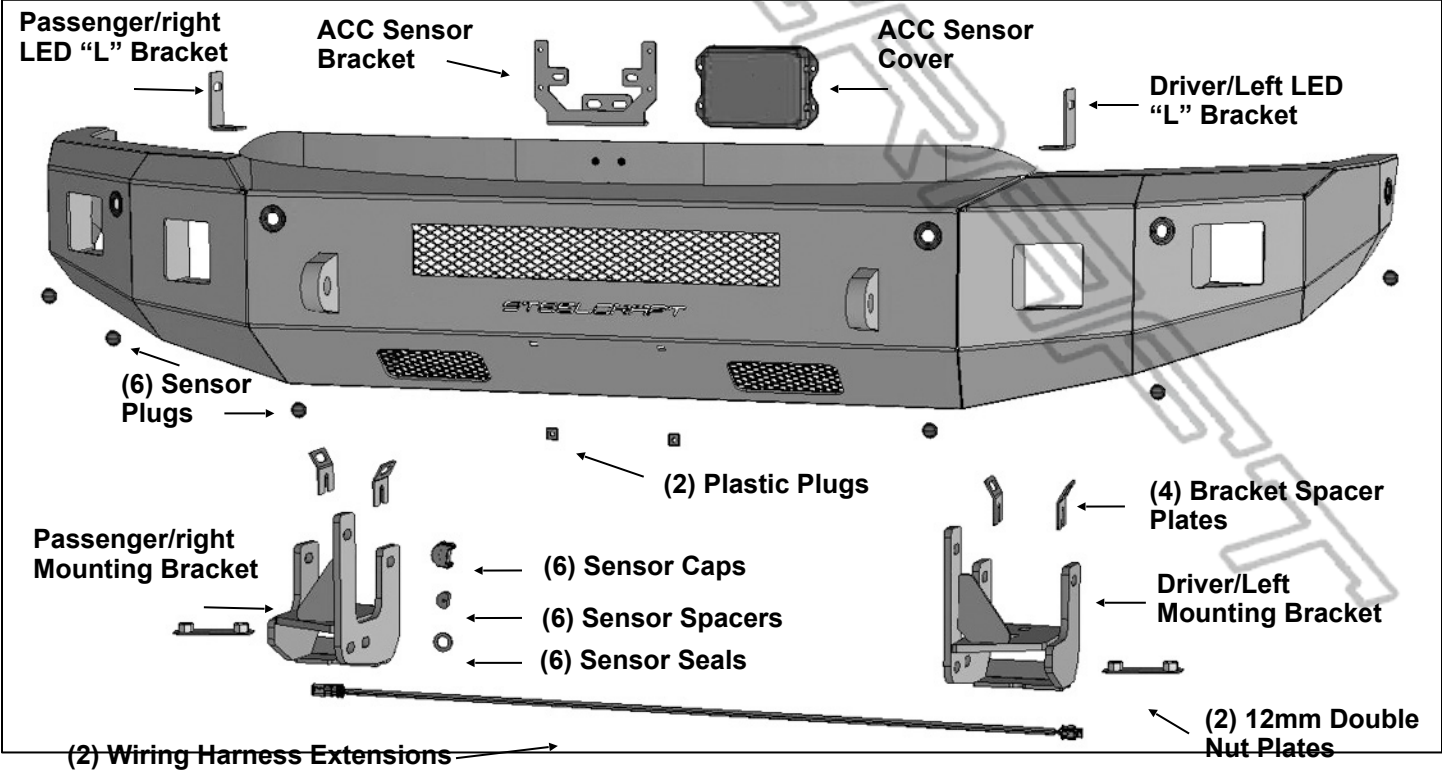

**PROCEDURE:**

**REMOVE CONTENTS FROM BOX. VERIFY ALL PARTS ARE PRESENT. READ INSTRUCTIONS CAREFULLY BEFORE STARTING INSTALLATION. BUMPER IS HEAVY, ASSISTANCE IS RECOMMENDED TO AVOID POSSIBLE INJURY OR DAMAGE TO THE VEHICLE.**

1. Remove the license plate and bracket if equipped.
2. From behind the front bumper, unplug and remove the active air dam from the bottom of the frame, **(Figures 1 & 2)**. It is not necessary to remove the lift motors, only remove the (6) bolts to remove the air dam. Active air dam does not get re-installed.
3. With the air dam out of the way, locate and unplug the main harness plug on the top of the passenger/right frame rail behind the bumper bracket, **(Figure 3)**. Unplug any remaining harnesses leading to the bumper. On hybrid models, temporarily unplug and remove the speaker assembly for the pedestrian audible alert system from the driver/left frame channel, **(Figure 4)**. Note speaker is located on the inner side of the frame, behind the driver/left bumper bracket. From below, remove the hex bolt and drop the speaker down, unplug and remove, **(Figure 5)**.
4. Place blocks or jack stands under the front bumper to support it during mounting hardware removal. Once the bumper has been safely supported, remove the large hex nuts from the back of each bumper bracket attaching the bumper to the bumper brackets, **(Figure 6)**. **WARNING!** Assistance is required to hold the bumper in place during hardware removal to prevent the bumper from falling. Carefully slide the bumper off over the tow hooks if equipped.
5. Remove both tow hooks if equipped, **(Figure 6)**. Tow hooks cannot be reinstalled.
6. On models with bolt-on frame extensions, remove the extensions from outside of frame, **(Figure 6)**. **NOTE:** It may be necessary to cut the bolts to remove frame extensions, (removal is optional).
7. Models without tow hooks, insert (1) 12mm Double Nut Plate into the end of the driver/left side of the frame and over the two holes in the bottom of the frame, **(Figures 6 & 7)**.
8. Select the driver/left Frame Mounting Bracket, **(Figure 7)**. Attach the Bracket to the bottom of the frame and inner Double Nut Plate with the included (2) 12mm x 45mm Hex Bolts, (2) 12mm Lock Washers and (2) 12mm Flat Washers, **(Figures 7 & 8)**. Do not fully tighten hardware at this time.
9. Next, insert (1) 12mm x 170mm Long Hex Bolt with (1) 12mm Flat Washer the Frame Bracket and frame, **(Figures 7 & 9)**. Secure the Bracket to the frame with (1) 12mm Flat Washer, (1) 12mm Lock Washer and (1) 12mm Hex Nut. **NOTE:** On models with ecoboost, it may be necessary to temporarily remove the hardware attaching the intercooler shutter assembly to insert the long Hex Bolt.
10. Slide (2) "U" Bracket Spacers, (1 on inner, 1 on outer side of frame), down between the side of the frame and the inside of the Frame Bracket, **(Figure 7)**. **NOTE:** On models with ecoboost, reattach assembly once Hex Bolt has been installed. Do not fully tighten hardware.
11. Repeat **Steps 7—10** to install the passenger/right Frame Bracket. Hybrid models: re-install speaker.
12. Disassemble front bumper to unplug and remove sensors and wiring harness from bumper. Pay attention to mounting location of all sensors for proper reinstallation.
13. Determine if the vehicle is equipped front sensors:

**Models without bumper sensors:**

- a. Select the included (6) Plastic Plugs.
- b. From the front, push the plugs into the sensor mounting holes, **(Figure 10)**.

**Models with bumper mounted parking sensors:**

- a. Select the driver/left outer sensor. Remove the silicone seal from the end of the sensor. Slide the included larger Foam Sensor Seal over front of sensor, **(Figure 11)**.
- b. Insert sensor with Seal into driver/left outer sensor mount, **(Figure 12)**.
- c. Place Foam Spacer over end of sensor. Push Sensor Retaining Cap onto sensor mount and lock into mounting holes, **(Figure 12)**.
- d. Repeat previous Steps to install remaining sensors.
- e. Install wiring harness for parking sensors, **(Figure 17)**. **NOTE:** Use the included (2) Wire Harness Extensions to extend the length of the factory harness to reach all sensors.

**Models with Adaptive Cruise Control (ACC).**

- a. Remove the Rubber Plugs from the holes in the top of the Bumper, **(Figure 13)**.
- b. Select the Relocation Bracket. Attach the Bracket to the front of the Bumper with (2) 8mm x 25mm Hex Bolts, (4) 8mm Flat Washers, (2) 8mm Lock Washers and (2) 8mm Hex Nuts, **(Figure 13)**.
- c. Remove the ACC assembly from the vehicle. Remove the sensor from the bracket, **(Figure 14)**.
- d. Attach the sensor to the back of the Relocation Bracket with (2) 6mm x 25mm Button Head Bolts, (2) 6mm Lock Washers, (2) 6mm Flat Washers and (2) 6mm Flange Nuts, **(Figure 15)**.

- e. Attach the Plastic Sensor Cover to the front of the Bracket with the included (4) 5mm x 16mm Button Head Bolts, (4) 5mm Flat Washers, (4) 5mm Lock Washers and (4) 5mm Hex Nuts, **(Figure 16)**.
  - f. Fully tighten sensor mounting hardware.
  - g. Install wiring harness for parking sensors, **(Figure 17)**. **NOTE:** Unwrap the ACC harness from the bumper harness to extend the length of the ACC harness to reach the sensor.
- 14. Center LED light installation (sold separately).**
- a. Select the Left/Right “L” Brackets, **(Figure 18)**. Attach the Brackets to the top of the (2) mounting tabs welded onto the back of the bumper with the included 8mm x 25mm Hex Bolts, (4) 8mm Flat Washers, (2) 8mm Lock Washers and (2) 8mm Hex Nuts. Leave loose at this time.
  - b. Attach the LED light assembly to the “L” Brackets with the included (2) 8mm x 16mm Hex Bolts, (2) 8mm Lock Washers and (2) 8mm Flat Washers, **(Figure 18)**. Do not fully tighten hardware at this time. **IMPORTANT:** “L” Brackets are designed for 8mm light mounting hardware only. Modify “L” Brackets if necessary or use brackets supplied by the light manufacturer, if possible, to install hardware larger than 8mm.
  - c. Follow light manufacturer’s instructions to properly wire the light to the vehicle.
15. With assistance, position the Bumper Assembly up to the inside of the Mounting Brackets. Temporarily support the weight of the Bumper. **NOTE:** On models with ecoboost, trim plastic shroud to fit Bumper profile as needed. **WARNING:** To avoid possible injury or damage to the vehicle, do not proceed until the bumper is fully and safely supported.
16. Attach the driver/left mounting plate on the back of the Bumper to the inside of the Mounting Bracket with the included (3) 12mm x 45mm Hex Bolts, (6) 12mm Flat Washers, (3) 12mm Lock Washers and (3) 12mm Hex Nuts, **(Figures 19 & 20)**. Repeat this **Step** to attach the passenger/right side of the Bumper to the Bracket. Do not fully tighten hardware at this time.
17. Level and adjust the bumper and fully tighten all hardware.
18. If front license plate is required, insert (2) Plastic Plugs into the square holes in the Bumper. Reuse the factory screws to attach the license plate to the Plastic Plugs, **(Figure 21)**.
19. Do periodic inspections to the installation to make sure that all hardware is secure and tight.

**To protect your investment,** Do not use any type of polish or wax that may contain abrasives that could damage the finish. Mild soap may be used to clean the Bumper assembly.

### Driver/left Side Installation Pictured

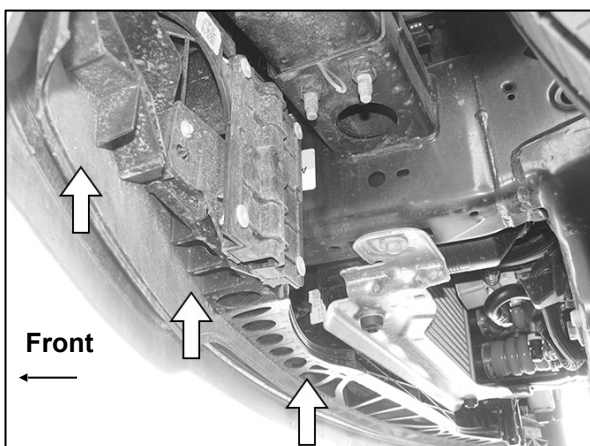

**(Fig 1) Active air dam behind bumper**

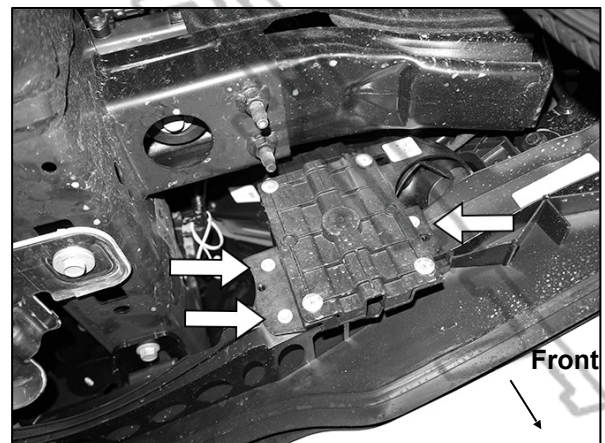

**(Fig 2) Remove bolts (arrows) to remove active air dam from motors (passenger/ right side pictured)**

Driver/left Side Installation Pictured



(Fig 3) Locate and unplug main harness plug on passenger/right side of bumper (arrow)

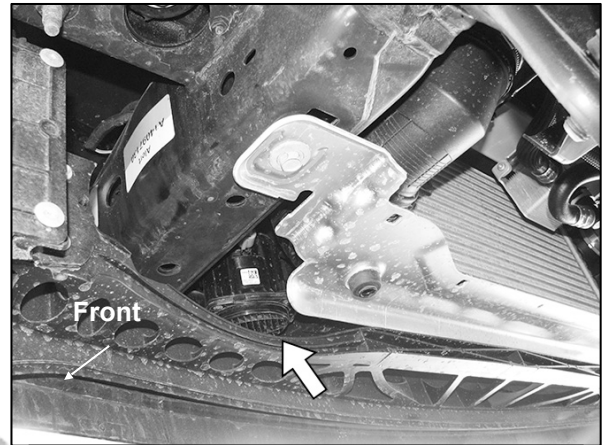

(Fig 4) Hybrid Models Only, locate alert speaker behind driver/left side of bumper



(Fig 5) Remove bolt (arrow) to temporarily remove audible alert speaker located behind driver/left side of bumper (hybrid models only-pictured from below)

**WARNING!** Do not remove bumper bolts unless it is properly supported on blocks or stands or the bumper may fall.

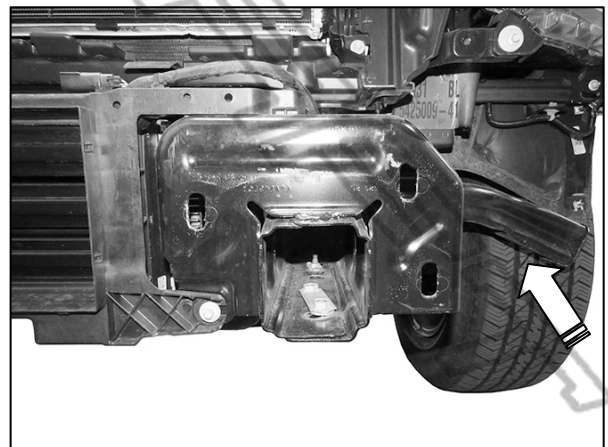

(Fig 6) Remove bumper. Also remove the factory frame extension (arrow-optional)

Driver/left Side Installation Pictured

Use either factory double nut plate or the included 12mm Double Nut Plate

12mm x 170mm Hex Bolt  
(2) 12mm Flat Washers  
12mm Lock Washer  
12mm Hex Nut

**WARNING!** Do not remove bumper bolts unless it is properly supported on blocks or stands or the bumper may fall.

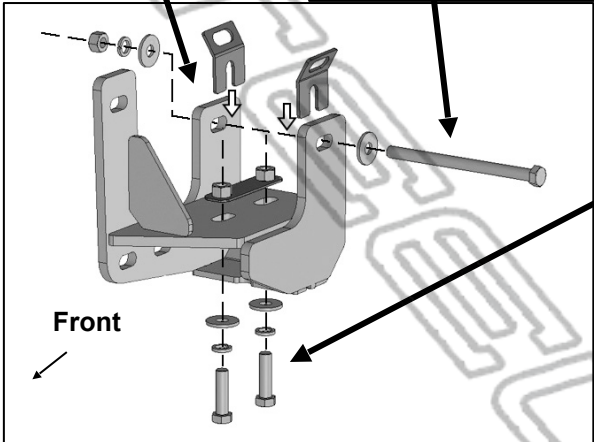

(2) 12mm x 45mm Hex Bolts  
(2) 12mm Lock Washers  
(2) 12mm Flat Washers

(Fig 7) Attach driver/left Frame Mounting Bracket to end of frame. Insert "U" Bracket Spacers between side of frame and inside of Frame Bracket (driver/left side Bracket illustrated)

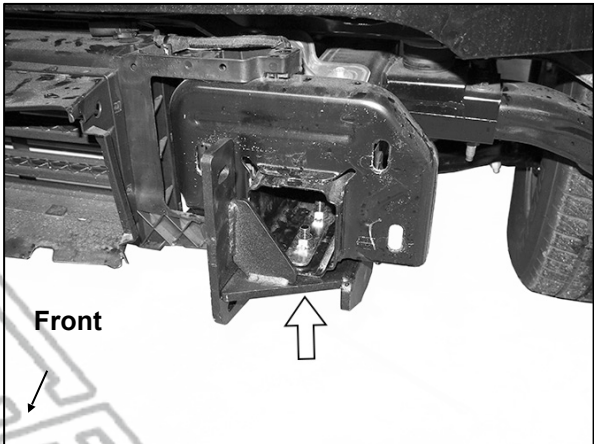

(Fig 8) Driver/left Frame Mounting Bracket attached to inner Double Nut Plate (arrow)

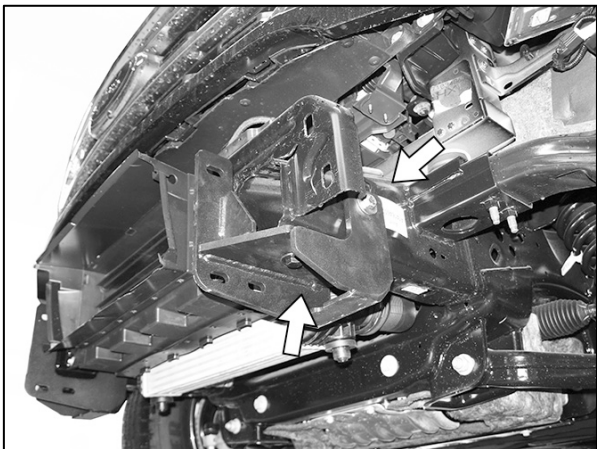

(Fig 9) Driver/left Frame Mounting Bracket attached to inner end of frame (arrows)

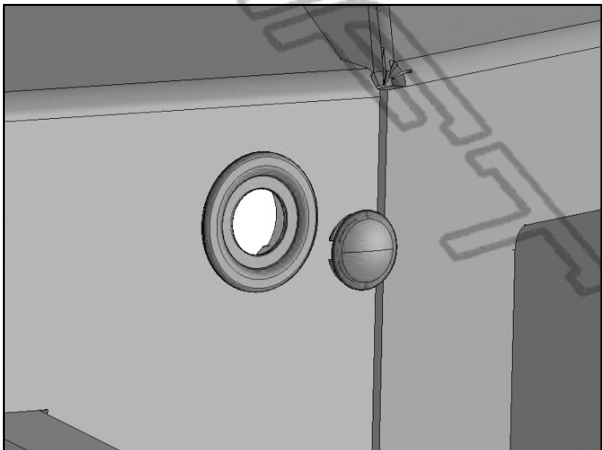

(Fig 10) Push Plastic Plug into sensor mount

Driver/left Side Installation Pictured

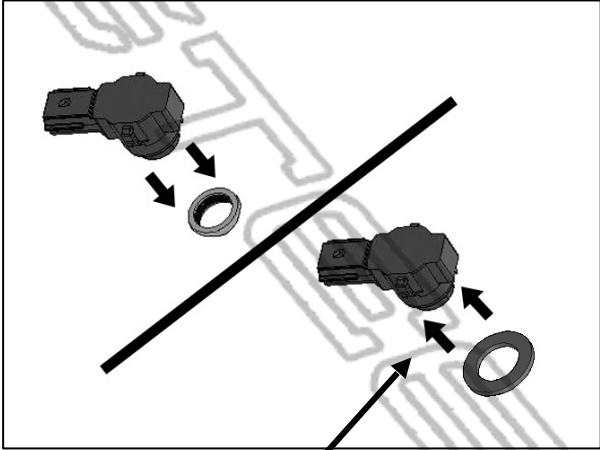

(Fig 11) Remove silicone seal from sensor. Slide large Seal over end of sensor (arrow)

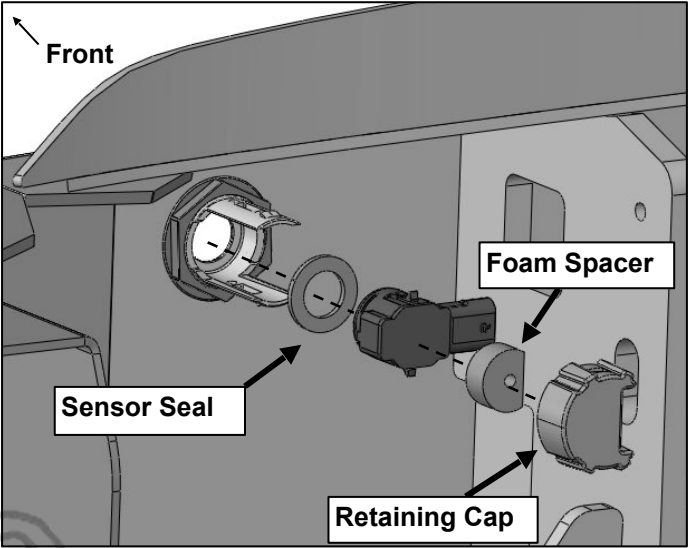

(Fig 12) Insert sensor assembly into the sensor mount on back of Bumper

- (2) 8mm x 25mm Hex Bolts
- (4) 8mm Flat Washers
- (2) 8mm Lock Washers
- (2) 8mm Hex Nuts

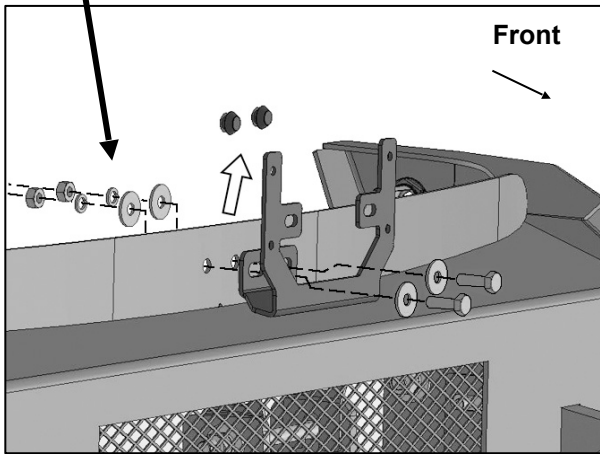

(Fig 13) Models equipped with ACC, remove Rubber Plugs to attach Relocation Bracket.

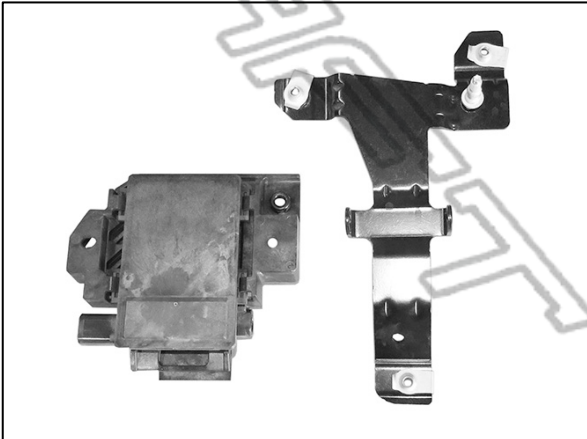

(Fig 14) Models equipped with ACC, remove sensor from mounting bracket

Driver/left Side Installation Pictured

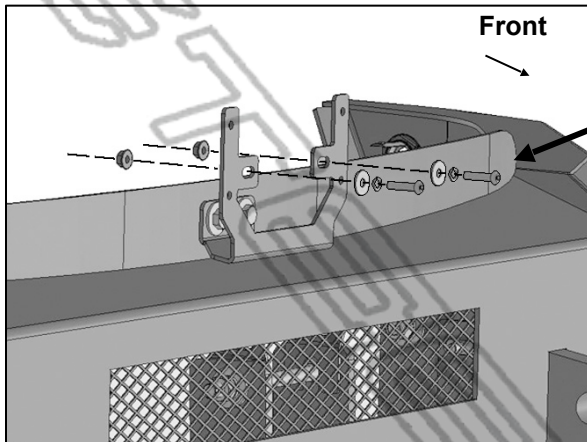

- (2) 6mm x 25mm Button Head Bolts
- (2) 6mm Lock Washers
- (2) 6mm Flat Washers
- (2) 6mm Flange Nuts

(Fig 15) Models equipped with ACC, attach sensor to back of Relocation Bracket

- (4) 5mm x 16mm Button Head Bolts
- (4) 5mm Flat Washers
- (4) 5mm Lock Washers
- (4) 5mm Hex Nuts

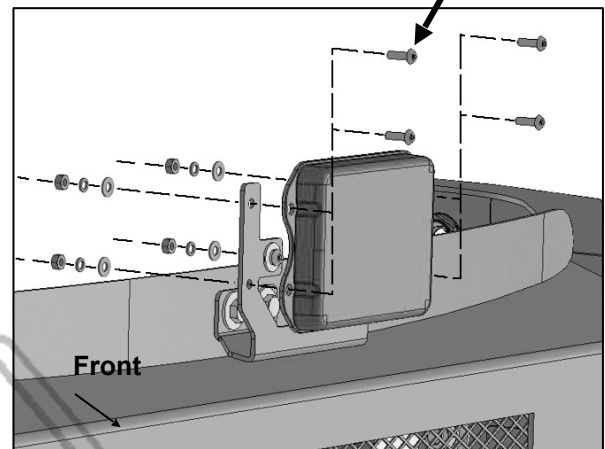

(Fig 16) Models with ACC, attach Plastic Cover to front of Relocation Bracket

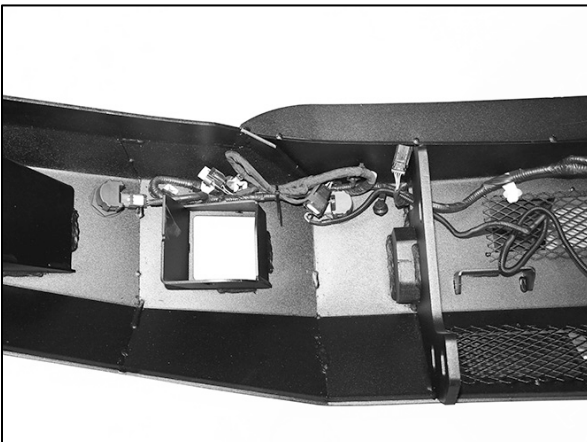

(Fig 17) Attach factory wiring harness to back of Bumper. Plug harness into sensors. Use included Harness Extensions to reach sensors. Models with ACC sensor, unwrap harness to extend ACC sensor wiring (left side pictured)

- 8mm x 16mm Hex Bolt
- 8mm Lock Washer
- 8mm Flat Washer

- 8mm x 25mm Hex Bolt
- (2) 8mm Flat Washers
- 8mm Lock Washer
- 8mm Hex Nut

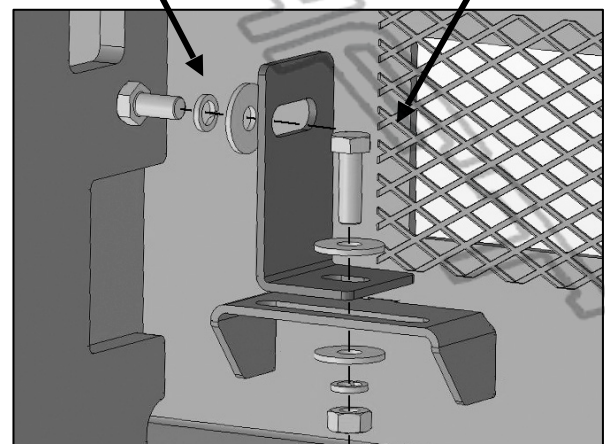

(Fig 18) Attach Left/Right LED Brackets to tabs on back of Bumper (left side illustrated)

**WARNING!** Do not crawl under bumper unless it is properly supported on blocks or stands or the bumper may fall.

Driver/left Side Installation Pictured

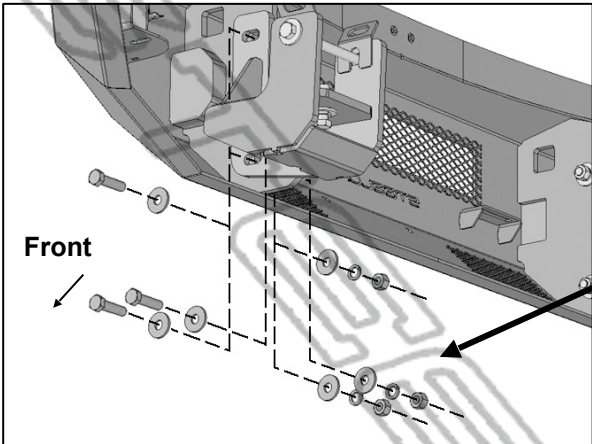

(Fig 19) Attach Bumper to Frame Mounting Bracket (driver/left side illustrated)

**WARNING!** Do not crawl under bumper unless it is properly supported on blocks or stands or the bumper may fall.

- (3) 12mm x 45mm Hex Bolts
- (6) 12mm Flat Washers
- (3) 12mm Lock Washers
- (3) 12mm Hex Nuts

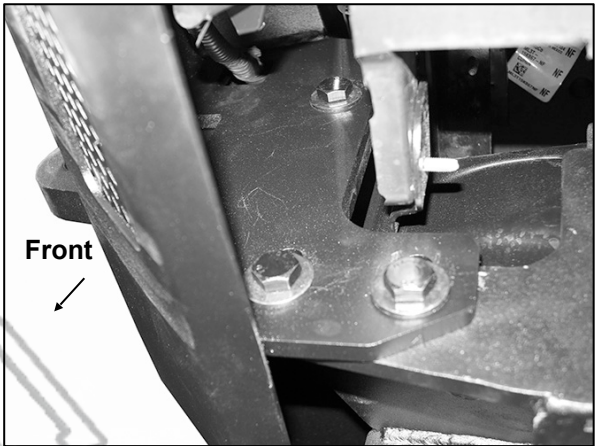

(Fig 20) Passenger/right side complete installation

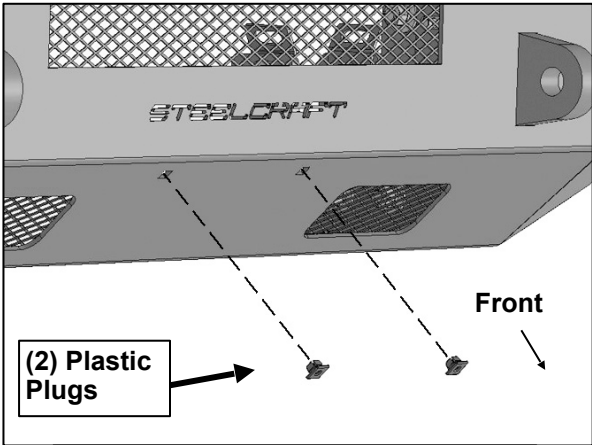

(2) Plastic Plugs

(Fig 21) Reuse factory screws to attach license plate to Plastic Plugs

