

PARTS LIST:

1	HD Rear Bumper	4	12mm x 45mm Hex Bolts
1	Driver/Left Frame Bracket	8	12mm x 37mm x 3mm Flat Washers
1	Passenger/Right Frame Bracket	4	12mm Nylon Lock Nuts
1	Driver/Left Support Bracket	2	8mm x 25mm Hex Bolts
1	Passenger/Right Support Bracket	4	8mm x 16mm x 1.6mm Flat Washers
1	Driver/Left BSS Relocation Bracket	2	8mm Lock Washers
1	Passenger/Right BSS Relocation Bracket	2	8mm Hex Nuts
2	Plastic BSS Covers	6	6mm x 30mm Hex Bolts
2	License Plate Plugs	12	6mm x 12mm x 1.6mm Flat Washers
1	License Plate Light	6	6mm Lock Washers
4	Sensor Plugs	6	6mm Hex Nuts
1	Sensor Cover Kit	8	5mm x 16mm Hex Bolts
8	14-1.5mm x 55mm Fine Thread Hex Bolts	8	5mm Lock Washers
16	14mm x 28mm x 2.5mm Flat Washers	8	5mm x 10mm x 1mm Flat Washers
8	14mm Lock Washers	8	4mm Button Head Screws
8	14mm Fine Thread Hex Nuts	1	2.5mm Hex Wrench

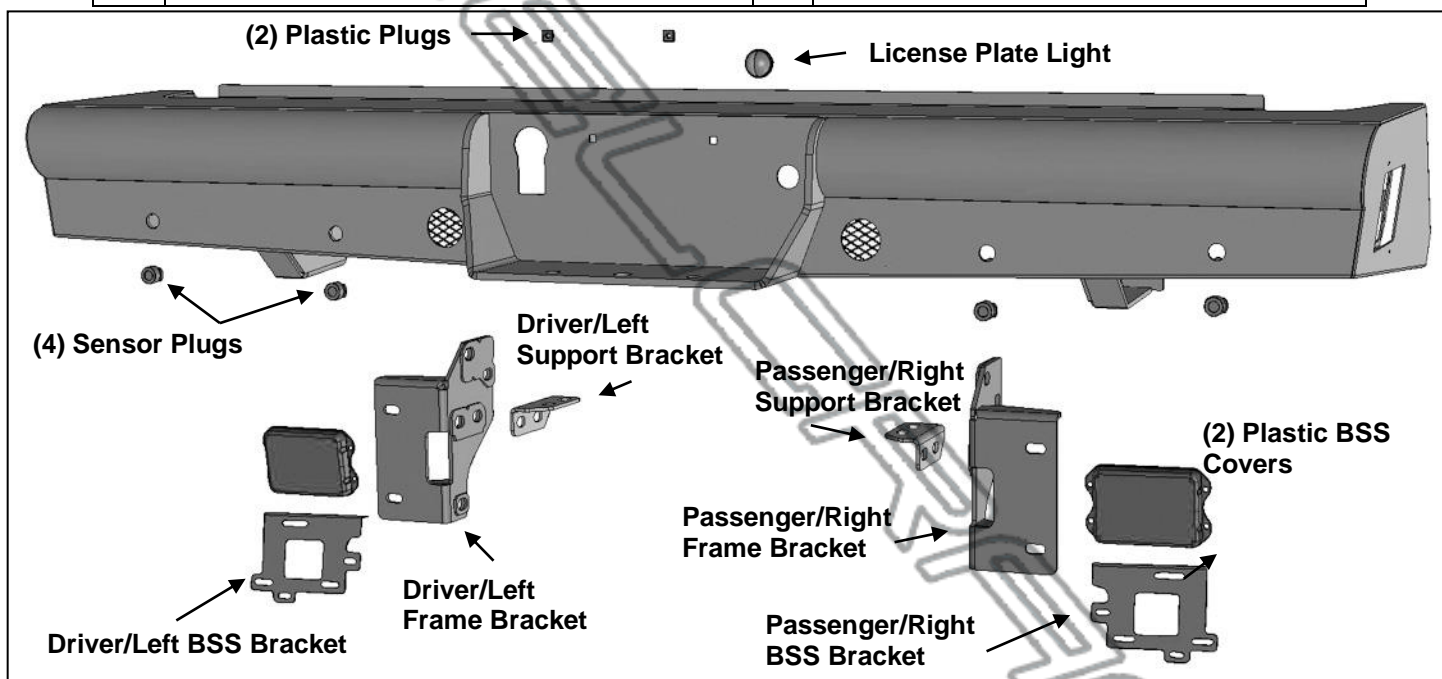

PROCEDURE:

REMOVE CONTENTS FROM BOX. VERIFY ALL PARTS ARE PRESENT. READ INSTRUCTIONS CAREFULLY BEFORE STARTING INSTALLATION. BUMPER IS HEAVY, ASSISTANCE IS RECOMMENDED TO AVOID POSSIBLE INJURY OR DAMAGE TO THE VEHICLE.

1. Begin at the rear of the vehicle. Remove the license plate from the bumper. Unplug the wiring harness leading to the rear bumper (**Figure 1**). Move all wiring harnesses away from bumper.
2. **Determine if vehicle is equipped with a factory receiver hitch.**

Models without Factory Receiver Hitch

- a. Place blocks or jack stands under the bumper to support it during factory bolt removal. Once the bumper has been safely supported, remove the factory hardware attaching the bumper brackets to the side of the frame, (**Figure 2**). Remove complete Bumper with brackets from frame.
- b. Select the Driver/Left Support Bracket. Reuse the (2) factory bolts to attach the Bracket to the bottom of the frame, (**Figure 3 & 4**).

- c. Select the Driver/Left Mounting Bracket. Attach the Bracket to the outside of the frame and Support Bracket with (4) 14mm Hex Bolts, (8) 14mm Flat Washers, (4) 14mm Lock Washers, and (4) 14mm Hex Nuts **(Figure 5)**. Do not tighten hardware at this time.
- d. Repeat previous **Steps** to attach the Passenger/Right Support Bracket and Mounting Bracket to the frame.

Models with Factory Receiver Hitch

- a. Remove the plastic screw from behind the license plate, **(Figure 6)**. Release the clips and factory hardware attaching the bottom of the outer bumper to the receiver hitch, **(Figure 7)**.
 - b. Use a flat blade screwdriver to pry up and remove the plastic cover from the top of the bumper, **(Figure 8)**.
 - c. Place blocks or jack stands under the bumper to support it during bolt removal. Once the bumper has been safely supported, remove the hardware attaching the bumper to the top of the receiver hitch and remove the bumper **(Figure 8)**. **NOTE:** Leave hitch attached to vehicle.
 - d. Select the Driver/Left Mounting Bracket. Attach the Bracket to the outside of the receiver hitch with (4) 14mm Hex Bolts, (6) 14mm Flat Washers, (4) 14mm Lock Washers and (2) 14mm Hex Nuts, **(Figure 9 & 10)**. Reuse (1) factory bolt to attach the top hole in the Bracket to the hitch. Do not tighten hardware at this time. Repeat previous **Steps** to attach the Passenger/Right Mounting Bracket to the frame.
3. Remove the wiring harness and sensors if equipped. Mark each sensor with location for reassembly.
 4. Determine if vehicle is equipped with parking and blind spot (BSS) sensors.

Models without parking sensors,

- a. Insert (4) Sensor Plugs into mounts. Secure with (8) 4mm Button Head Bolts, **(Figure 12)**.

Models with parking sensors,

- a. Remove the plastic ring from the driver/left outer sensor, **(Figure 11)**. Insert the ring into the front of the sensor mount in the Bumper, **(Figure 21)**.
 - b. Push the sensor into the back of the Sensor Mount and into the plastic ring. Secure Sensor to mount with (2) 4mm Button Head Screws, **(Figure 12)**. Screws are used to hold sensor in place, do not overtighten Screws or sensor may be damaged.
 - c. Repeat previous Steps to install remaining parking sensors.
5. All models, select (1) Plastic Cover. Attach the Cover to the inside of the driver/left end of the Bumper with (4) 5mm Hex Bolts, (4) 5mm Lock Washers and (4) 5mm Flat Washers, **(Figure 13)**. Repeat this Step to install the passenger/right side Cover.

Models with BSS "blind spot" sensors.

- a. Select the Driver/Left BSS Bracket and sensor, **(Figures 14A or 14B)**, the shape of the sensor differs depending on vehicle model year (MY 2014-17, MY 2018-21). Attach the BSS sensor to the Bracket with (3) 6mm Hex Bolts, (6) 6mm Flat Washers, (3) 6mm Lock Washers and (3) 6mm Hex Nuts. Depending on vehicle model year, the BSS sensor will either mount vertically or horizontally. **(Figures 15A & 15B)**.
 - b. Attach the sensor Bracket assembly to the inside of the bumper with (1) 8mm Hex Bolt, (2) 8mm Flat Washers, (1) 8mm Lock Washer and (1) 8mm Hex Nut, **(Figure 16)**.
 - c. Repeat previous Steps to install the passenger/right BSS sensor.
6. Install the wiring harness. Plug harness into sensors if equipped.
 7. Locate the mounting slots in the tabs on the back of the Bumper to install lights if desired, **(Figure 17)**. **NOTE:** Lights not included.
 8. With assistance, position the Bumper Assembly up to the Mounting Brackets. Temporarily support the weight of the Bumper. **WARNING:** To avoid possible injury or damage to the vehicle, do not proceed until the bumper is fully and safely supported.
 9. Attach the Bumper to the Mounting Brackets with the included (4) 12mm Hex Bolts, (8) 12mm Flat Washers and (4) 12mm Nylon Lock Nuts to the back of the bumper, **(Figures 18 & 19)**. Do not fully tighten hardware.
 10. Level and adjust the bumper and fully tighten all hardware.
 11. Reinstall the trailer plug, **(Figures 20 & 21)**. **NOTE:** Use a flat blade screwdriver to carefully pry the metal clip on the plug out to grab the edge of the opening if necessary.

12. Insert (2) License Plate Plugs into the holes in the bumper. Insert the License Plate Light into the bumper and connect to bumper wiring harness, **(Figure 20)**.
13. Reattach the bumper wiring harnesses to the main harness.
14. Do periodic inspections to the installation to make sure that all hardware is secure and tight.

To protect your investment, Do not use any type of polish or wax that may contain abrasives that could damage the finish. Mild soap may be used to clean the Bumper assembly.

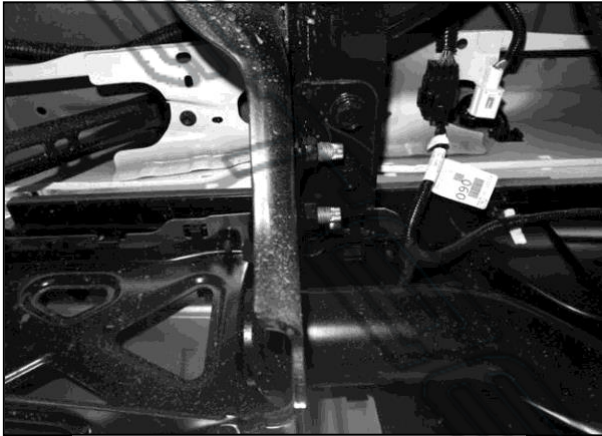

(Fig 1) Unplug all wire harnesses leading to rear bumper

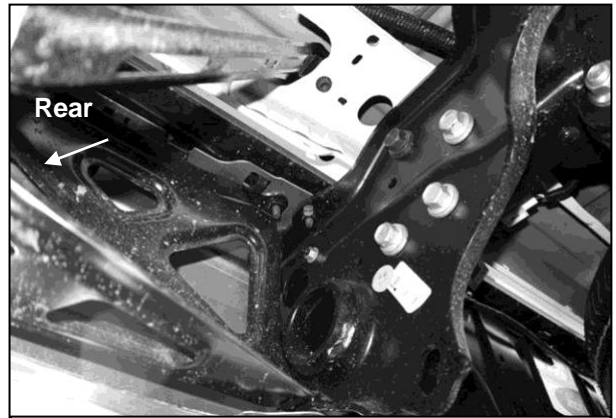

(Fig 2) Models without receiver hitch, remove bolts attaching bumper assembly to frame

Reuse factory hardware if equipped

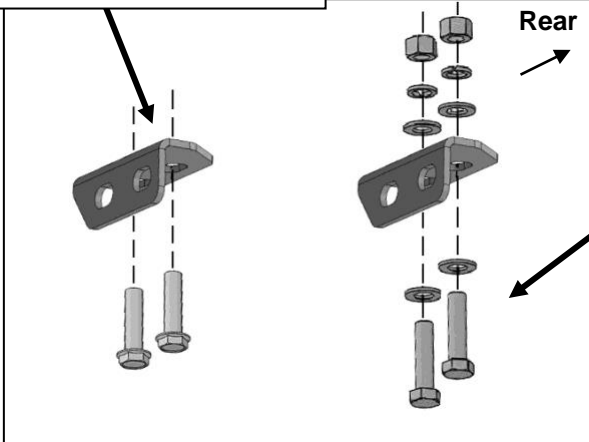

(Fig 3) Models without receiver hitch, attach Support Bracket to bottom of frame (driver/left side Support Bracket illustrated)

Models without factory hardware use:
(2) 14mm Hex Bolts
(4) 14mm Flat Washers
(2) 14mm Lock Washers
(2) 14mm Hex Nuts

WARNING! Do not remove bumper bolts unless the bumper is properly supported on blocks or stands or it may fall.

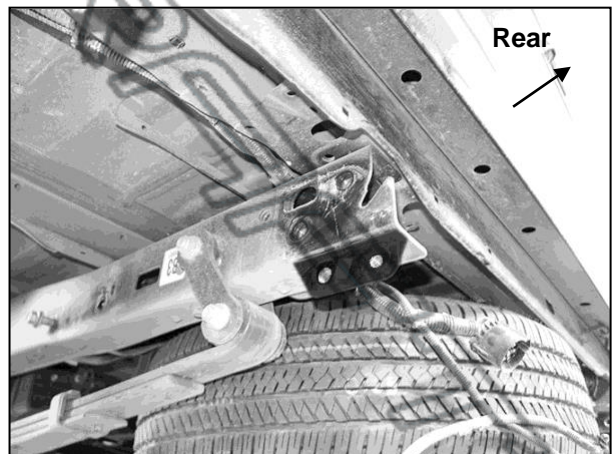

(Fig 4) Attach driver/left Support Bracket to bottom of frame (Models without hitch only)

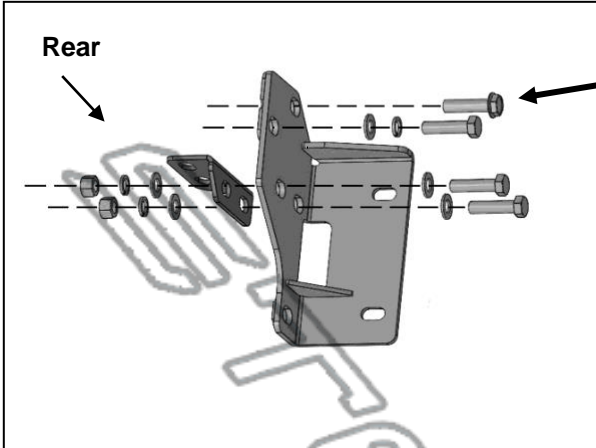

(Fig 5) Attach Driver/Left Bracket to side of frame and Support Bracket (without hitch)

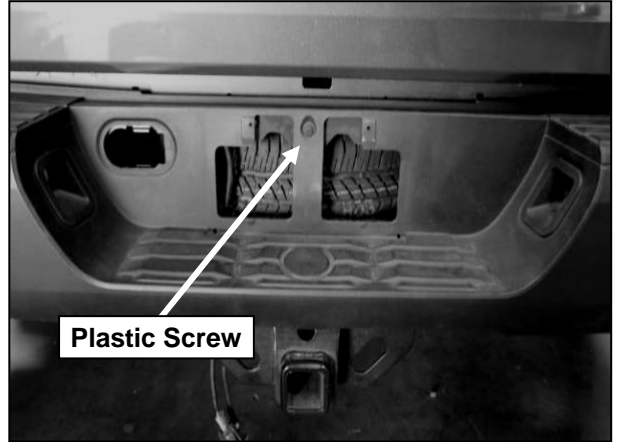

(Fig 6) Models with receiver hitch, remove plastic screw behind the license plate.

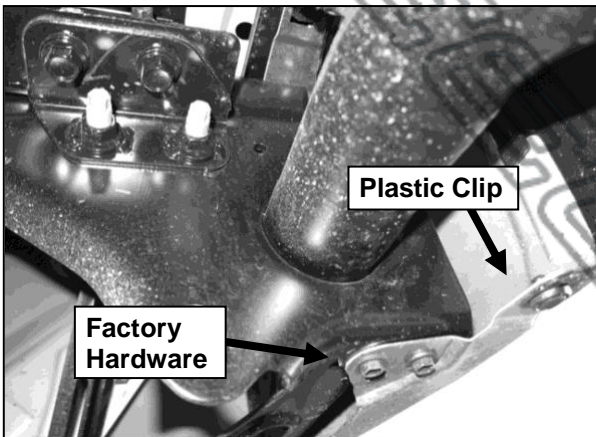

(Fig 7) Remove Factory Hardware and Plastic Clip from the underside of the bumper

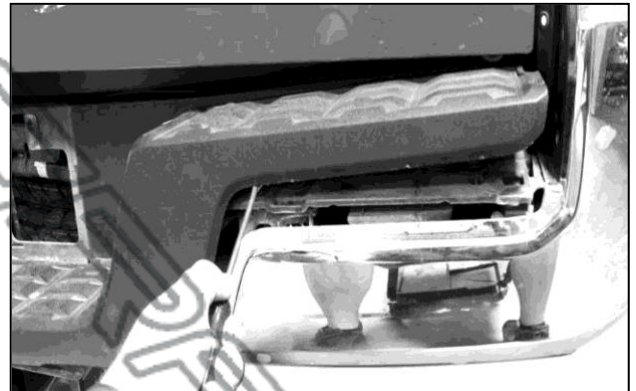

(Fig 8) Use a flat blade screwdriver to pry the plastic cover up from the bumper to access bolts attaching top of bumper to inner bracket

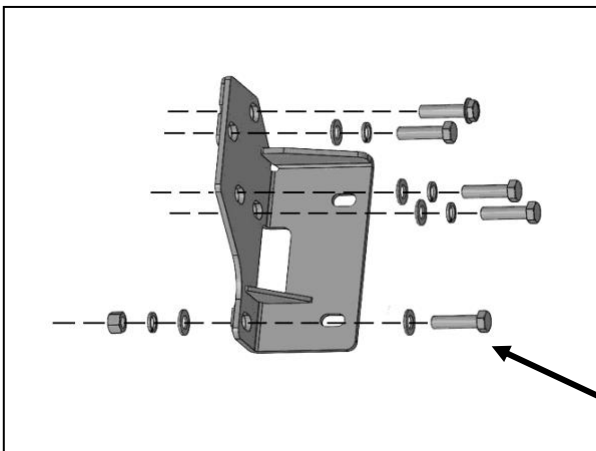

(Fig 9) Attach Driver/Left Mounting Bracket to side of frame and receiver hitch when equipped

Lower bolt is only used if the vehicle is equipped with a hitch

14mm Hex Bolt
14mm Lock Washer
14mm Flat Washer

Or reuse factory
bolts if long enough

(3) 14mm Hex Bolts
(6) 14mm Flat Washers
(3) 14mm Lock Washers
(3) 14mm Hex Nuts

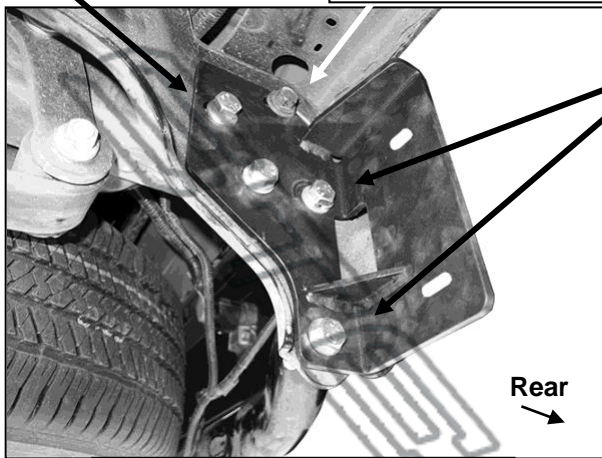

(Fig 10) Driver/Left Mounting
Bracket to Hitch Plate installed

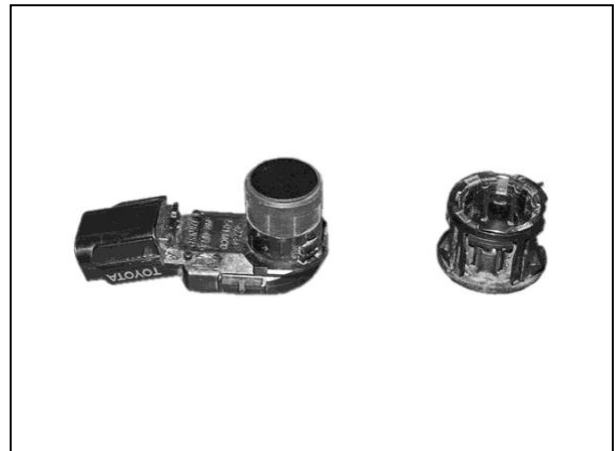

(Fig 11) Remove sensor from plastic ring.
Push plastic ring into sensor mount from
outside of Bumper, push sensor into sensor
mount and ring from back of Bumper

(2) 4mm Screws

Sensor Plug

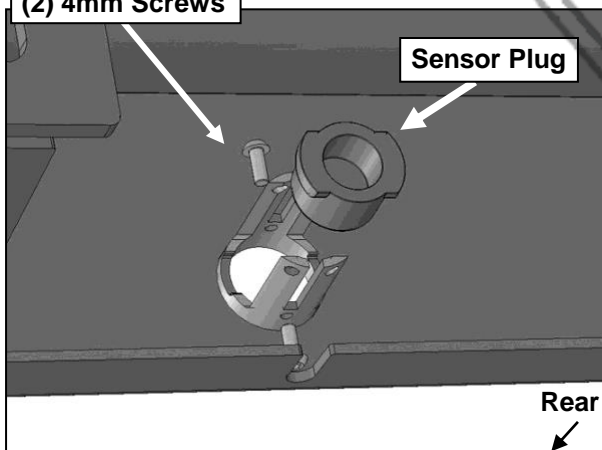

(Fig 12) Push Sensor into sensor mount and
plastic ring, (Fig 11). Use 4mm Screws to
lock in place. (Models without sensors, insert
Rubber Plug)

(4) 5mm Hex Bolts
(4) 5mm Lock Washers
(4) 5mm Flat Washers

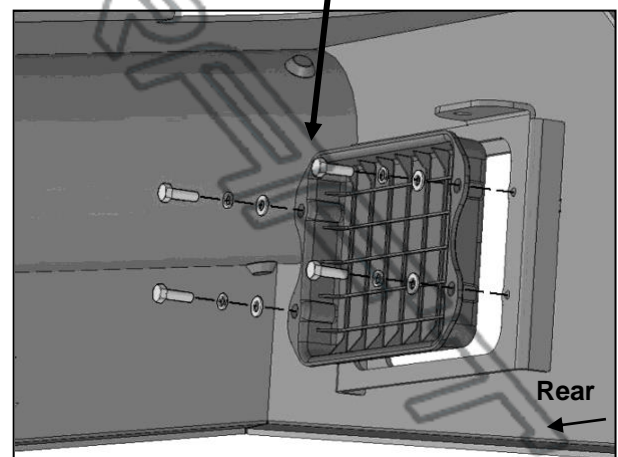

(Fig 13) BSS Plastic Cover to Bumper
installation (Driver/Left shown)

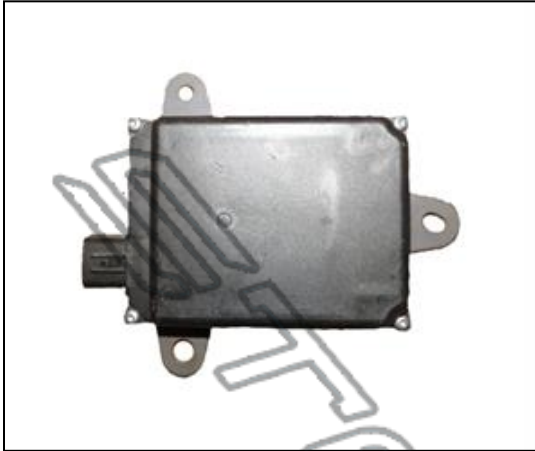

(Fig 14A) Blind Spot Sensor (BSS)
pictured (Model years 2014-17)



(Fig 14B) Blind Spot Sensor (BSS)
pictured (Model years 2018-21)

- (3) 6mm Hex Bolts
- (6) 6mm Flat Washers
- (3) 6mm Lock Washers
- (3) 6mm Hex Nuts

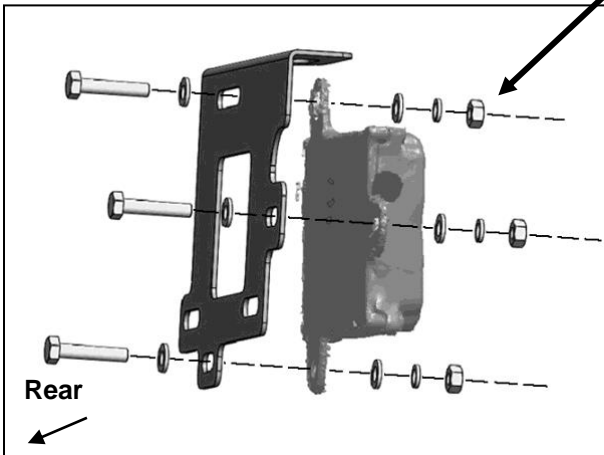

(Fig 15A) Driver/Left BSS
installation (Model years 2014-17)

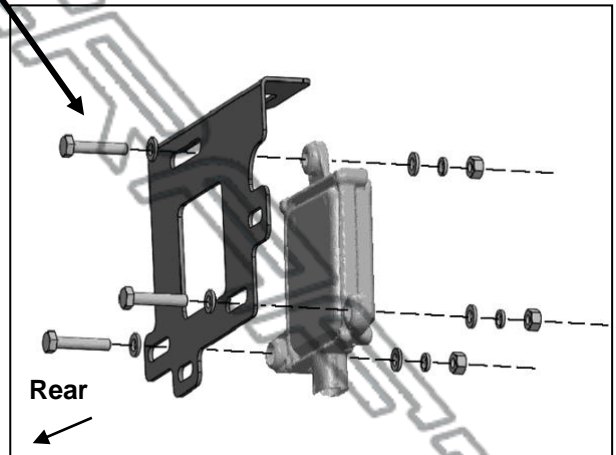

(Fig 15B) Driver/Left BSS
installation (Model years 2018-21)

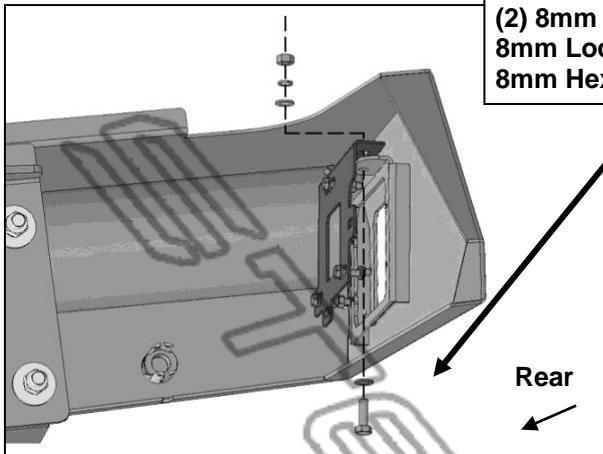

8mm Hex Bolt
(2) 8mm Flat Washers
8mm Lock Washer
8mm Hex Nut

WARNING! Do not crawl under bumper unless it is properly supported on blocks or stands or the bumper may fall.

(Fig 16) Driver/Left BSS Bracket to Bumper installation

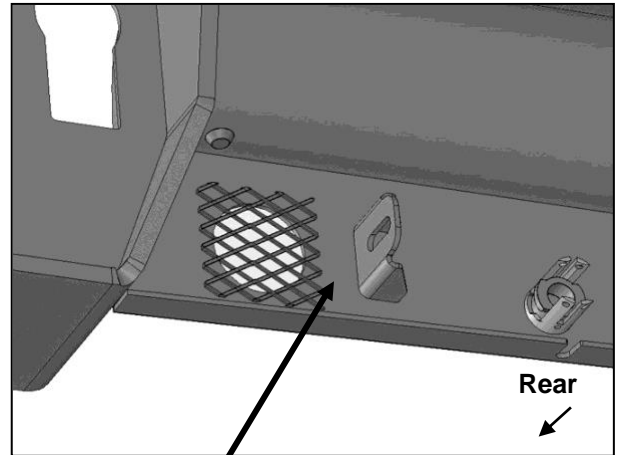

(Fig 17) Accessory light mounting location

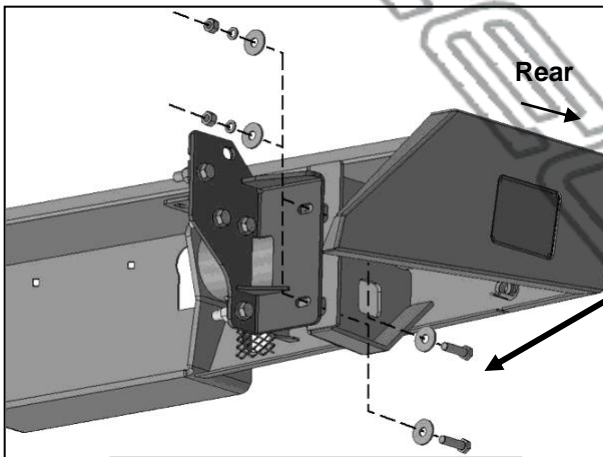

(2) 12mm Hex Bolts
(4) 12mm Flat Washers
(2) 12mm Lock Washers
(2) 12mm Hex Nuts

(Fig 18) Bumper to Driver/Left Mounting Bracket installation



(Fig 19) Bumper installed to Driver/Left Mounting Bracket

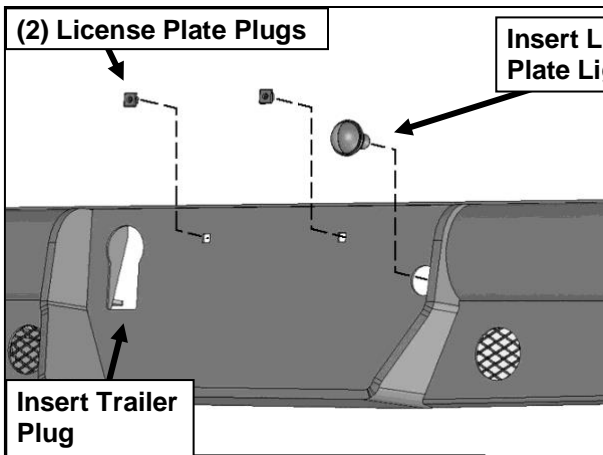

(Fig 20) Push plastic plugs into holes for license plate