

**FORTIS MAXX FRONT BUMPER  
2017-22 FORD SUPER DUTY**

**PARTS LIST:**

1	Front Bumper	7	6mm x 25mm Button Head Bolts
1	Driver/left Mounting Bracket	11	6mm Lock Washers
1	Passenger/right Mounting Bracket	7	6mm Hex Nuts
1	Driver/left LED Light Bar L-bracket	14	6mm x 18mm x 1.6mm Flat Washers
1	Passenger/right LED Light Bar L-bracket	4	6mm x 16mm Hex Bolts
2	Plastic Plugs for license plate mount	2	8-1.25mm x 16mm Hex Bolts
1	Driver/left Fog Light Mount (OEM LED)	6	8-1.25mm x 25mm Hex Bolts
1	Passenger/right Fog Light Mount (OEM LED)	8	8mm Lock Washers
2	Lower U-Brackets (OEM fog light only)	14	8mm x 24mm x 2mm STD Flat Washers
1	Driver/left Light Block Off Plate	6	8mm Hex Nuts
1	Passenger/right Light Block Off Plate	14	12-1.75mm x 50mm Hex Bolts
1	Driver/left Upper Bracket (OEM fog light)	32	12mm x 32mm x 3mm Flat Washers
1	Passenger/right Upper Bracket (OEM fog light)	18	12mm Lock Washers
1	ACC Adapter Bracket	18	12-1.75mm Hex Nuts
1	ACC Mounting Bracket	4	12mm x 50mm Bolt Plates
1	ACC Plastic Cover	1	4mm Allen Wrench
4	12mm Plastic Retainers		

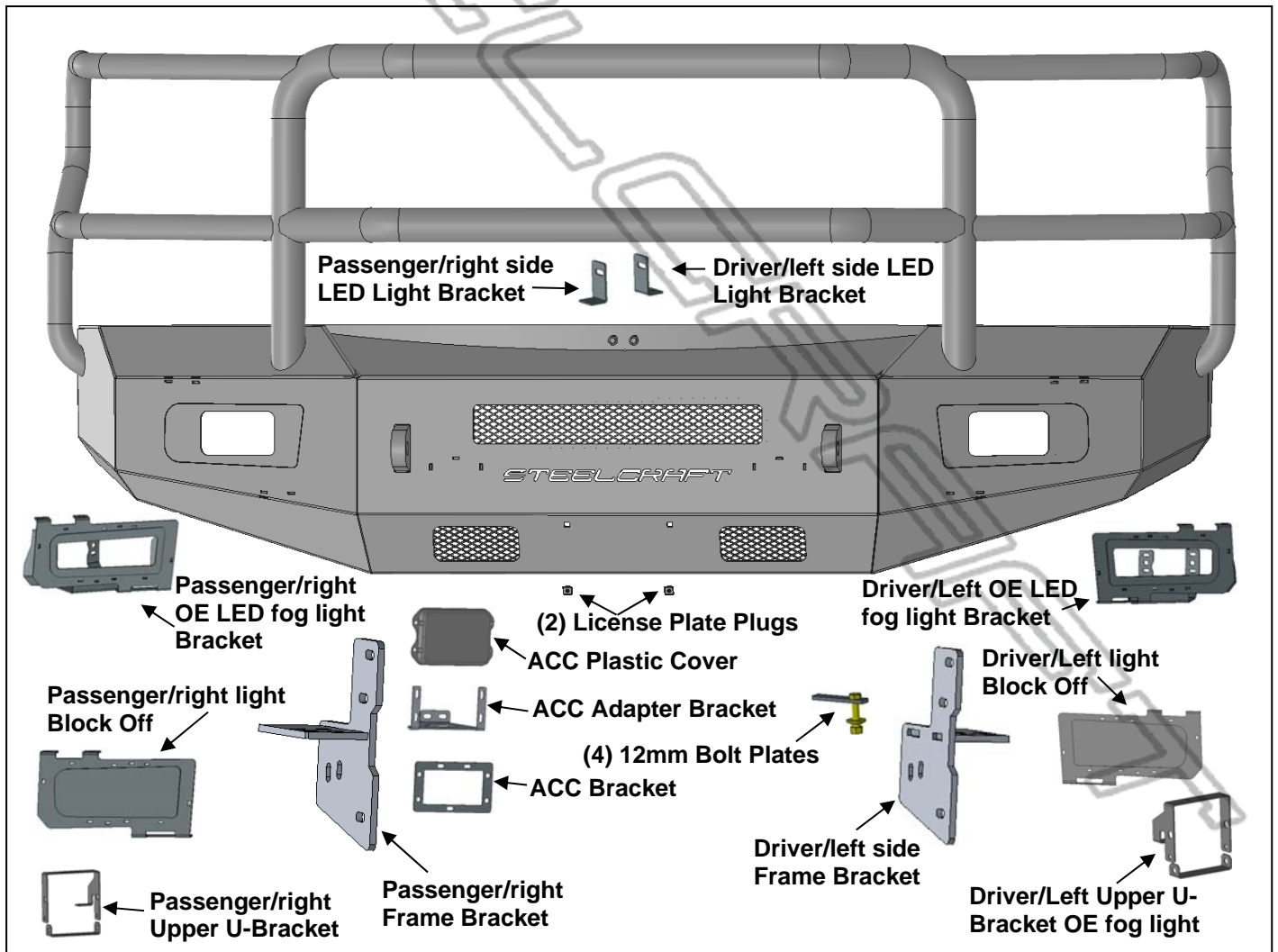

**PROCEDURE:**

**REMOVE CONTENTS FROM PACKAGING. SOME PARTS ARE SMALL AND WILL BE HIDDEN IN WRAPPINGS. VERIFY ALL PARTS ARE PRESENT AND DO NOT DISCARD PACKAGING UNTIL INSTALLATION IS COMPLETE. READ INSTRUCTIONS CAREFULLY BEFORE STARTING INSTALLATION. BUMPER IS HEAVY, ASSISTANCE IS HIGHLY RECOMMENDED TO AVOID POSSIBLE INJURY OR DAMAGE TO THE VEHICLE.**

1. Remove the license plate and bracket. On models with factory fog lights, unplug wiring harness leading to the front bumper, **(Figure 1)**. Unplug and remove the adaptive cruise control, if equipped.
2. Remove the bumper supports attaching the outer ends of the bumper to the outside of the frame, **(Figure 2)**. Remove the plastic covers from the tow hooks to uncover the bumper bolts, **(Figure 3)**.
3. Place blocks or jack stands under the front bumper to support it during mounting bolt removal. Once the bumper has been safely supported, remove the (8) factory bumper bolts, **(Figure 4)**.  
**WARNING!** Assistance is required to hold the bumper in place during bolt removal to prevent the bumper from falling. Carefully slide the bumper off over the tow hooks.
4. Remove the passenger/right side tow hook from the end of the frame, **(Figure 5)**. Next, remove the (4) factory hex nuts, lower frame extension and double bolt plates from the end of the frame, **(Figures 1 & 5)**. Repeat this **Step** to remove the driver/left side tow hook and lower frame extension. **NOTE:** Tow hooks cannot be reinstalled.
5. Locate the passenger/right side frame mounting location, **(Figure 6)**. Insert (2) 12mm Bolt Plates in through the frame channel and out the (2) inner holes of the frame, **(Figures 6 & 7)**. Use the (2) 12mm Plastic Retainers to secure the Bolt Plates tight against the frame. Select the Passenger/right side Mounting Bracket, **(Figure 7)**. Attach the Bracket to the Bolt Plates with (2) 12mm Flat Washers, (2) 12mm Lock Washers and (2) 12mm Hex Nuts, **(Figure 7)**. Do not tighten hardware at this time. **NOTE:** {2022 F-350 models: see page 10 for supplemental procedure}
6. Use the included (4) 12mm Hex Bolts, (8) 12mm Flat Washers, (4) 12mm Lock Washers and (4) 12mm Hex Nuts to attach the Bracket to the top of the frame, **(Figures 6 & 8)**. Do not tighten hardware.
7. Repeat **Steps 5 & 6** for Driver/left side Bracket installation.
8. Determine if model is equipped with fog lights and style of fog light.

**Models with rectangular factory fog lights:**

- a. Move to the driver/left fog light opening, **(Figure 9)**. Select the passenger/right top U-Bracket, **(Figure 10)**. Attach the Bracket to the slot in the light opening with the included (1) 8mm x 20mm Hex Bolt, (2) 8mm x 24mm STD Flat Washers and (1) 8mm Nylon Lock Nut, **(Figure 10)**.
- b. Use a flat blade screwdriver to carefully pop out the tabs on the side of the fog light bracket attaching the light to the bracket. Pop the light out of the plastic bracket housing.
- c. Remove the adjustment screw and spring from the light assembly.
- d. Spread the sides of the Bracket enough to slide the OE plastic fog light between and into the Bracket, **(Figure 11)**. Select (1) Lower U-Bracket. Attach the Lower Bracket to the Upper Bracket with (2) 6mm x 16mm Hex Bolts, (2) 6mm Lock Washers and (2) 6mm Flat Washers, **(Figure 12)**.
- e. Insert the factory spring between the tab on the Bracket and the light. Insert the screw through the tab, spring and into the fog light, **(Figure 12)**.
- f. Repeat **step** to install the passenger/right fog light.

**Models with optional narrow factory LED Fog Light (2020+ models):**

- a. Remove the light mount from the bumper, **(Figure 13)**. Remove the screws attaching the light to the plastic mount, **(Figure 14)**.
- b. Remove the preinstalled driver/left rectangular fog light mount insert from the back of the Bumper, **(Figure 15)**.
- c. Select the driver/left LED Fog light mount insert. Reuse the hardware to attach the Mount to the tabs on the back of the Bumper, **(Figure 16)**.
- d. Reuse the factory screws to attach the LED fog light to the LED light mount, **(Figure 17)**.
- e. Repeat **step** to install the passenger/right LED Light Mount and light.

**Models without fog lights.**

- a. Remove the preinstalled driver/left rectangular fog light mount insert from the back of the Bumper, **(Figure 15)**.
  - b. Select the driver/left Block Off. Reuse the hardware to attach the Block Off to the tabs on the back of the Bumper, **(Figure 16)**.
  - c. Repeat **step** to install the passenger/right Block Off.
- 9. Optional Center LED Light Bar installation** (sold separately).
- a. Select the L/R “L” Brackets. **NOTE:** “L” Brackets are offset for universal fitment for most LED bar style lights. Attach the LED light assembly to the “L” Brackets with the included (2) 8mm x 16mm Hex Bolts, (2) 8mm Lock Washers and (2) 8mm Flat Washers, **(Figure 18)**. Do not fully tighten hardware at this time. **NOTE:** “L” Brackets may require modification for hardware larger than 8mm or use brackets supplied with light if possible.
  - b. Attach the light and brackets to the top of the (2) tabs on the back of the Bumper with the included 8mm x 25mm Hex Bolts, (4) 8mm Flat Washers, (2) 8mm Lock Washers and (2) 8mm Hex Nuts, **(Figure 18)**. Adjust light position and tighten hardware.
  - c. Follow light manufacturer’s instructions to wire the light to the vehicle’s electrical system once Bumper has been fully installed.
- 10.** Determine if the vehicle is equipped with an adaptive cruise control, (ACC), and if equipped, note the design of the sensor. **Vehicles without ACC**, skip to **Step 12**.
- 11. Vehicles equipped with ACC sensor**, remove the rubber plugs from the top of the Bumper if equipped. Attach the ACC Bracket to the front of the bumper with (2) 8mm x 25mm Hex Bolts, (4) 8mm Flat Washers, (2) 8mm Lock Washers and (2) 8mm Hex Nuts, **(Figure 19)**.
- Vehicles with early style ACC with mounting tabs on ends.**
- a. Insert (4) 6mm x 25mm Button Head Bolts through the (4) holes in the ACC Plastic Cover, the ACC Bracket and out through the adaptive cruise control sensor, **(Figure 20)**. Secure with (4) 6mm Flat Washers, (4) 6mm Lock Washers and (4) 6mm Hex Nuts, **(Figure 21)**.
  - b. Tighten all ACC hardware and continue to **Step 12**.
- Vehicles with “late” style ACC with tabs on top and bottom.**
- a. Select the ACC Adapter Plate, **(Figure 22)**.
  - b. Attach the ACC sensor to the back of the Plate with the included (3) 6mm x 25mm Button Head Bolts, (6) 6mm Flat Washers, (3) 6mm Lock Washers and (3) 6mm Hex Nuts, **(Figure 22)**.
  - c. Insert (4) 6mm x 25mm Button Head Bolts through the (4) holes in the ACC Plastic Cover, the ACC Bracket and out through the Adapter Plate. Secure with (4) 6mm Flat Washers, (4) 6mm Lock Washers and (4) 6mm Hex Nuts, **(Figure 23)**.
- 12.** With assistance, carefully position the Bumper Assembly up to the inside of the Mounting Brackets, **(Figure 24)**. Temporarily support the weight of the Bumper. **WARNING:** To avoid possible injury or damage to the vehicle, do not proceed until the bumper is fully and safely supported.
- 13.** Attach the Bumper to the inside of the Mounting Brackets with the included (6) 12mm Hex Bolts, (12) 12mm Flat Washers, (6) 12mm Lock Washers and (6) 12mm Hex Nuts, **(Figure 24)**. Do not fully tighten.
- 14.** Insert (2) Plastic License Plate Plugs into the square holes in the front of the Bumper if front license plate is required. Reuse the factory screws to attach the license plate to the plastic plugs, **(Figure 25)**.
- 15.** Level and adjust the bumper and fully tighten all hardware.
- 16.** Do periodic inspections to the installation to make sure that all hardware is secure and tight.

**To protect your investment**, Do not use any type of polish or wax that may contain abrasives that could damage the finish. Mild soap may be used to clean the Front Bumper assembly.

FORTIS MAXX FRONT BUMPER  
2017-22 FORD SUPER DUTY

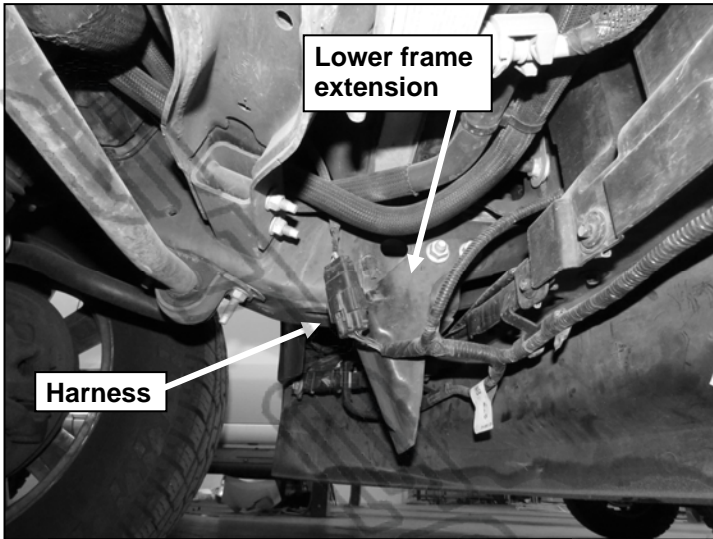

(Fig 1) Unplug wire harness from behind bumper (driver side pictured)

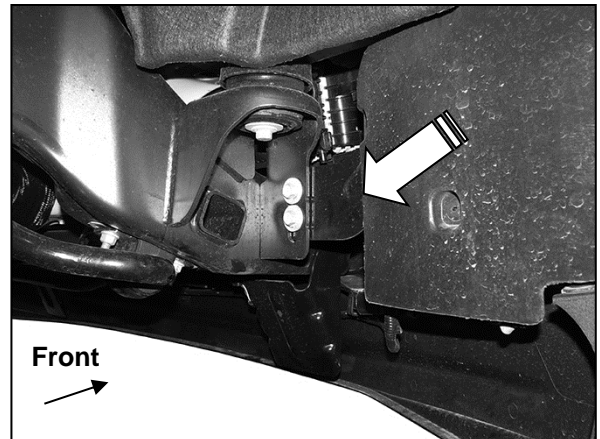

(Fig 2) Remove outer bumper support brackets between frame and bumper (arrow)

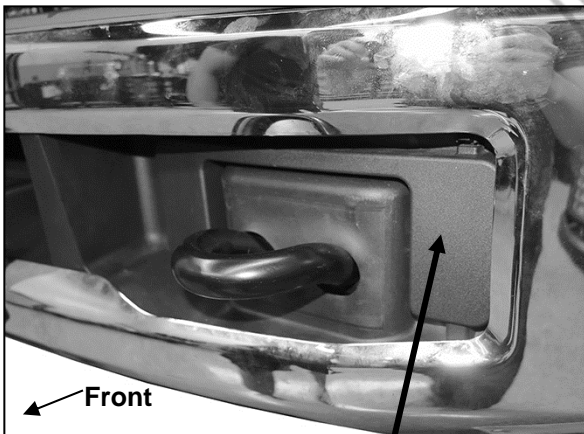

(Fig 3) Remove plastic cover around tow hook

**WARNING!** Do not remove bumper bolts unless the bumper is properly supported on blocks or stands or it may fall.



(Fig 4) Remove bumper bolts (driver/left side pictured)

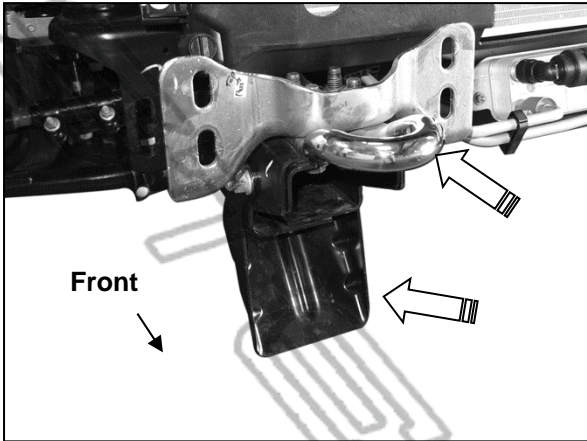

(Fig 5) Remove tow hook assembly and lower frame extension

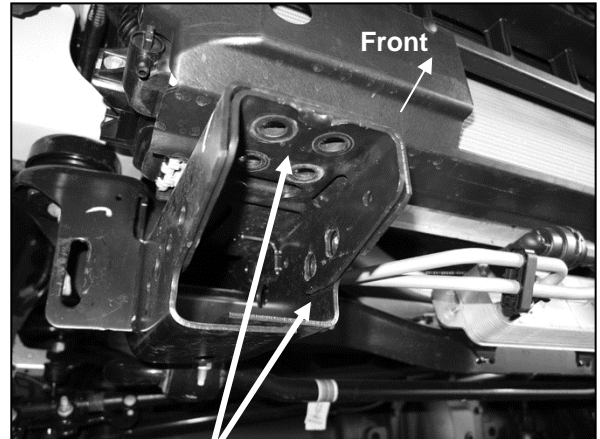

(Fig 6) Passenger/right frame mounting location

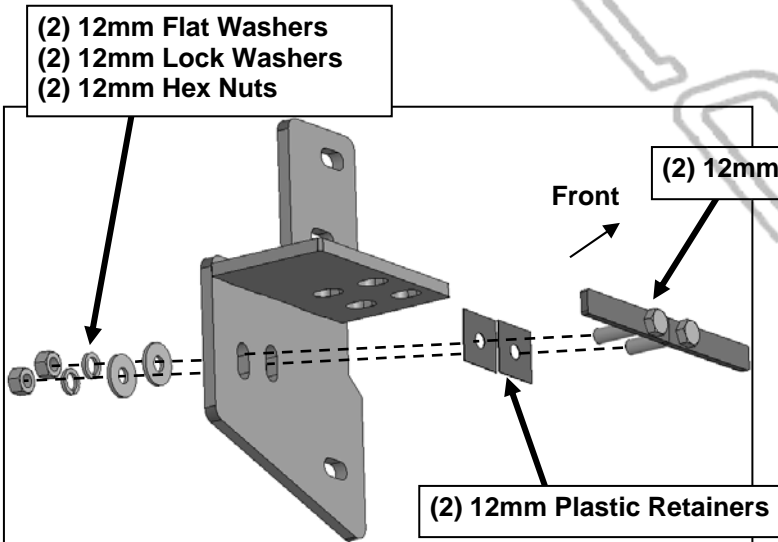

(Fig 7) Attach passenger/right side Mounting Bracket to the inner side of frame

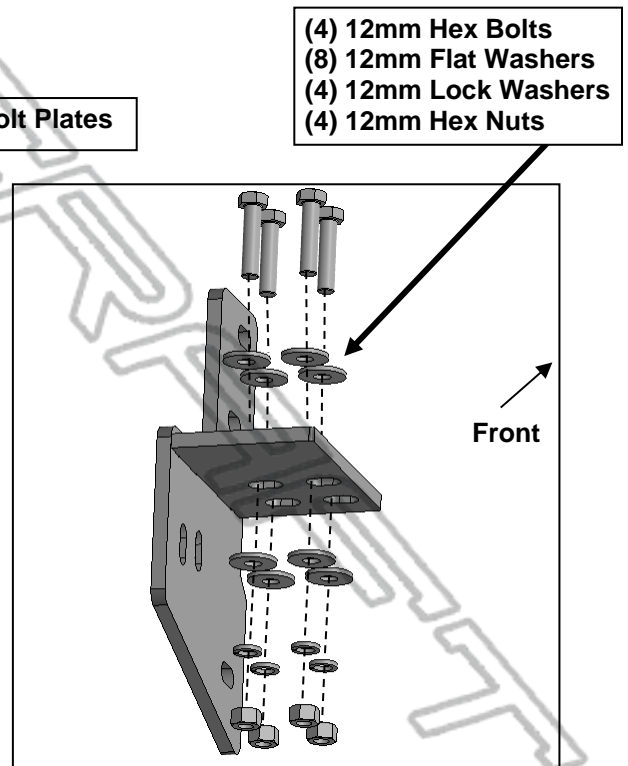

(Fig 8) Attach passenger/right Mounting Bracket to top of frame

Driver/left Side Installation Pictured

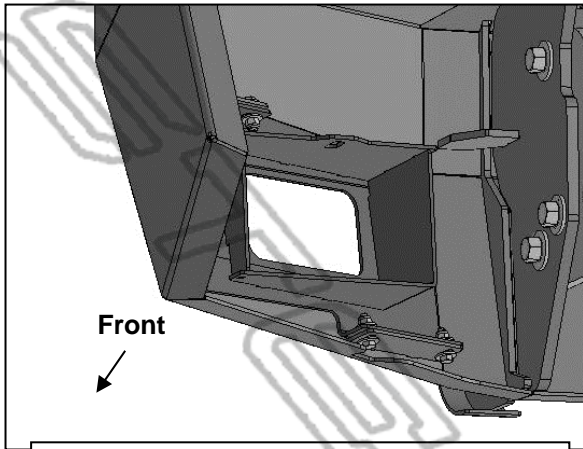

(Fig 9) Driver/left OE rectangular fog light mounting location

8mm x 25mm Hex Bolt  
(2) 8mm x 24mm Flat Washers  
8mm Lock Washer  
8mm Nylon Lock Nut

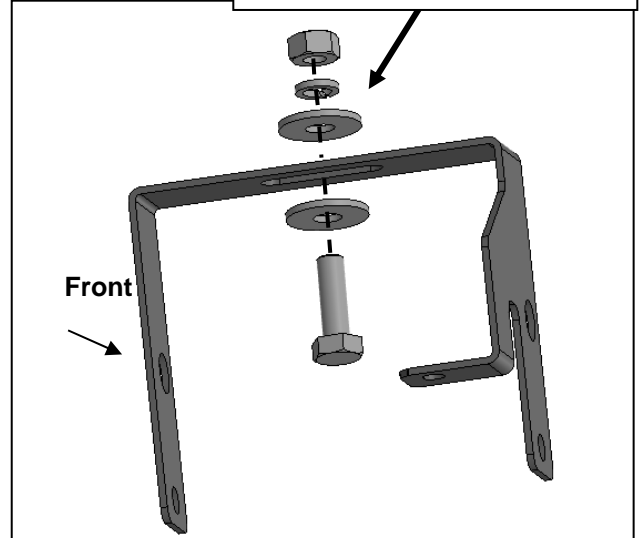

(Fig 10) OEM fog light installation (light not included). Attach driver/left Upper Bracket to the slot in top of the opening

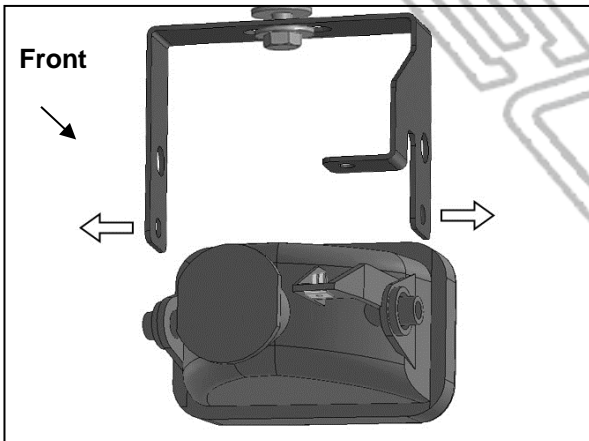

(Fig 11) Carefully spread sides to slide OEM fog light into position in pivot holes

6mm x 16mm Hex Bolt  
6mm Lock Washer  
6mm Flat Washer

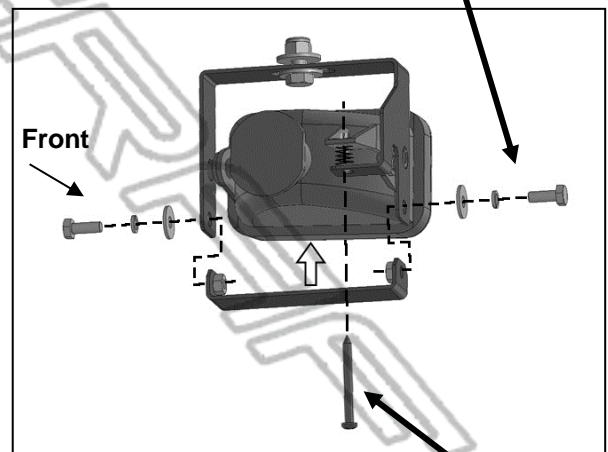

(Fig 12) Attach lower U Bracket to Upper Bracket. Reuse factory adjustment hardware (screw, spring and plastic nut)

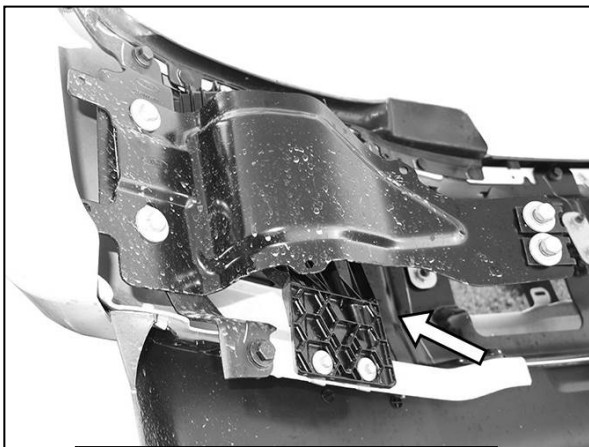

(Fig 13) Remove LED fog light assembly from factory bumper

**WARNING!** Do not crawl under bumper unless it is properly supported on blocks or stands or the bumper may fall.

Driver/left Side Installation Pictured

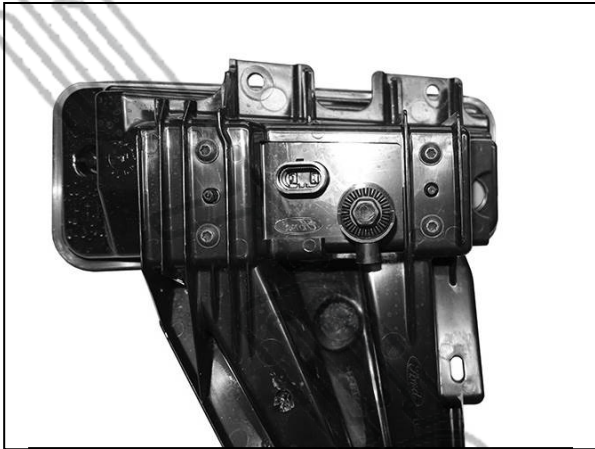

(Fig 14) Remove screws to remove narrow LED fog light from plastic mount

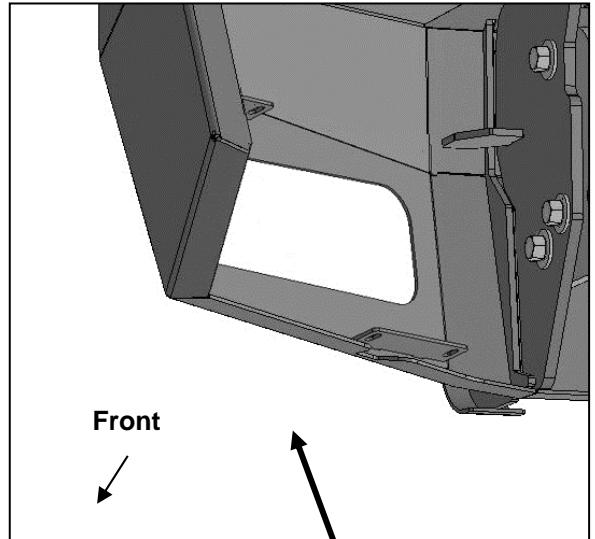

(Fig 15) Remove fog light mount from back of Bumper (driver/left side illustrated)

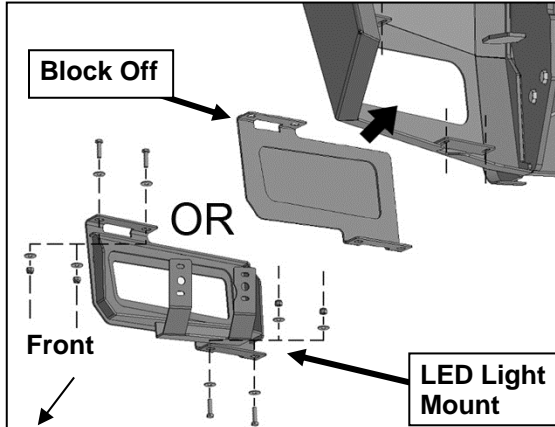

(Fig 16) Models with LED fog lights only, reuse screws to attach LED fog light to Light Mount. Reuse hardware to attach LED Fog Light assembly or Block Offs to tabs on back of Bumper

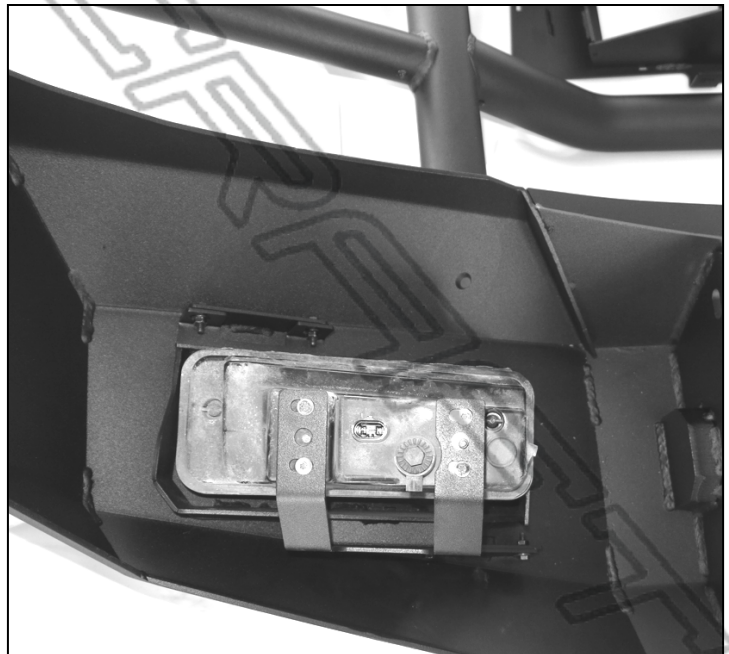

(Fig 17) LED fog light assembly installation complete.

**FORTIS MAXX FRONT BUMPER  
2017-22 FORD SUPERDUTY**

- (2) 8mm x 25mm Hex Bolts
- (4) 8mm Flat Washers
- (2) 8mm Lock Washers
- (2) 8mm Hex Nuts

- (2) 8mm x 16mm Hex Bolts
- (2) 8mm Lock Washers
- (2) 8mm Flat Washers

- (2) 8mm x 25mm Hex Bolts
- (4) 8mm Flat Washers
- (2) 8mm Lock Washers
- (2) 8mm Hex Nuts

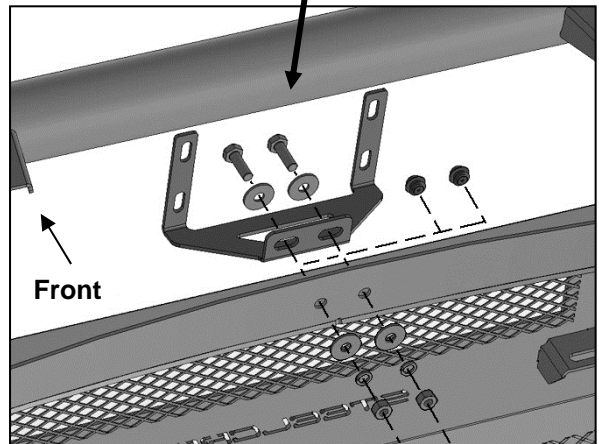
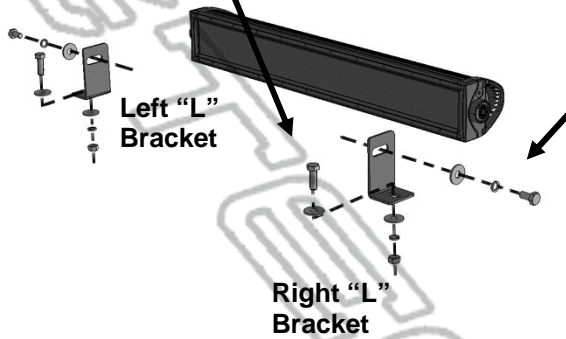

**(Fig 18) Example of LED Light Bar Installation**

**(Fig 19) Attach ACC Bracket to top of Bumper**

- (4) 6mm Button Head Bolts
- (4) 6mm Flat Washers
- (4) 6mm Lock Washers
- (4) 6mm Hex Nuts

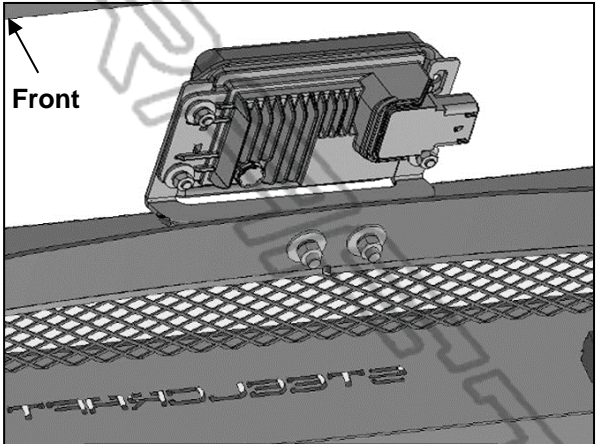
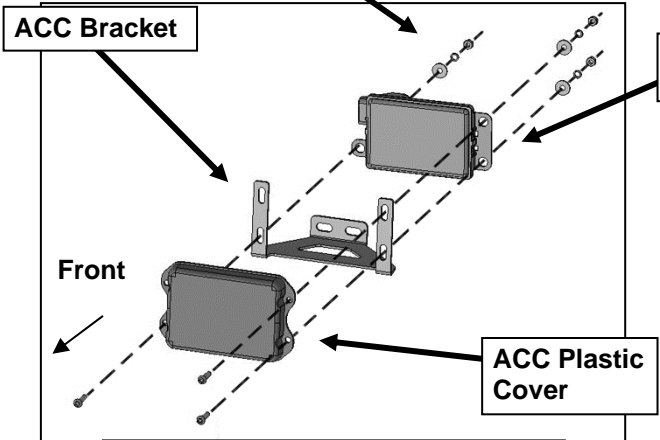

**(Fig 20) Attach "Early" ACC and plastic cover to the ACC Bracket**

**(Fig 21) "Early" ACC assembly attached to front of Bumper**



**FORTIS MAXX FRONT BUMPER  
2017-22 FORD SUPERDUTY**

- (3) 6mm Button Head Bolts
- (3) 6mm Flat Washers
- (3) 6mm Lock Washers
- (3) 6mm Hex Nuts

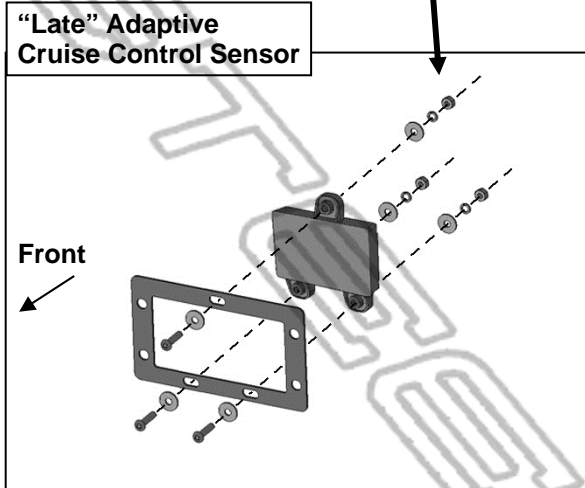

**(Fig 22) Attach "Late" ACC sensor to back of Adapter Bracket**

- (4) 6mm x 25mm Button Head Bolts
- (4) 6mm Flat Washers
- (4) 6mm Lock Washers
- (4) 6mm Hex Nuts

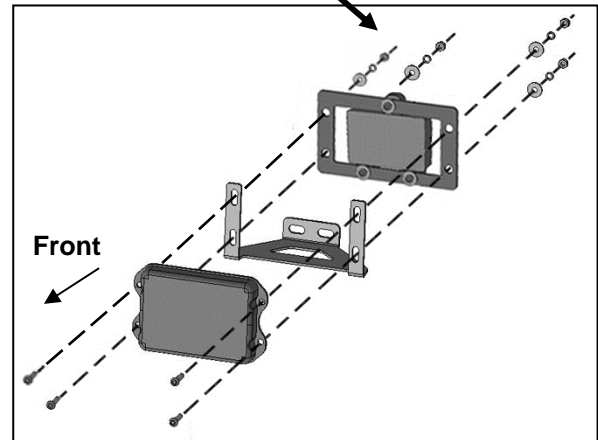

**(Fig 23) Attach Adapter Bracket with "Late" ACC and plastic cover to the ACC Bracket**

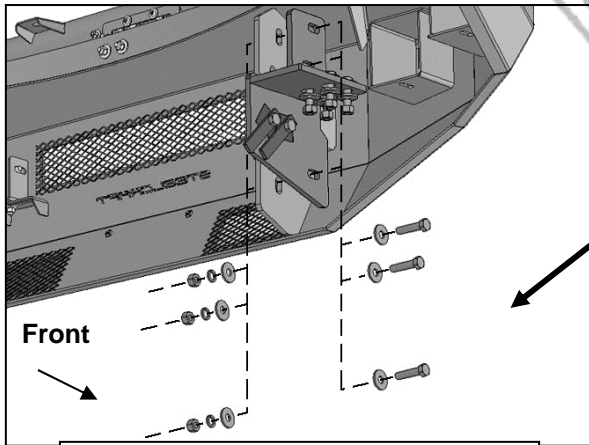

**(Fig 24) Attach passenger/right side of Bumper to Mounting Bracket**

- (3) 12mm Hex Bolts
- (6) 12mm Flat Washers
- (3) 12mm Lock Washers
- (3) 12mm Hex Nuts

**WARNING!** Do not crawl under bumper unless the bumper is properly supported on blocks or stands or the bumper may fall.

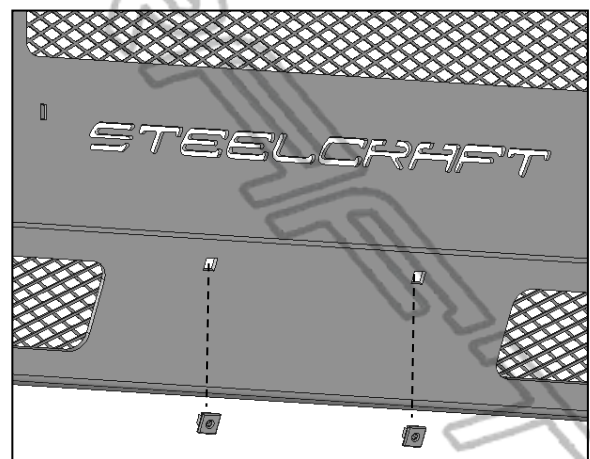

**(Fig 25) Push plastic plugs into holes in Bumper for license plate if required**

**Supplemental Installation Steps:** Some 2022 F-350's will have an extra cooler between frame.

- Trim tabs off OE cooler brackets so they rest flat against the bumper brackets:



- Install cooler onto forward bolt plate:

