

**ALUMINUM ELEVATION FRONT BUMPER
2023-25 FORD SUPER DUTY**

PARTS LIST:

1	Elevation Front Bumper Assembly	14	12-1.75mm x 50mm Hex Bolts
1	Driver/left Frame Bracket	36	12mm x 32mm x 3mm Flat Washers
1	Passenger/right Frame Bracket	22	12mm Lock Washers
1	Adaptive Cruise Control (ACC) Driver/left Bracket	22	12-1.75mm Hex Nuts
1	ACC Passenger/right side Bracket	2	8-1.25mm x 35mm Hex Bolts
1	ACC Cover Bracket	2	8mm Nylon Lock Nuts
1	ACC Plastic Cover	4	8mm x 28mm x 3mm Large Flat Washers
2	Plastic Plugs for license plate mount	4	6mm x 25mm Button Head Bolts
2	Parking Sensor Wire Extensions	3	6mm x 30mm Hex Bolts
1	Parking Sensor Cover Kit	2	6mm x 20mm Hex Bolts
4	Plastic Sensor Hole Plugs	14	6mm x 18mm x 1.6mm Flat Washers
4	Sensor Retaining Caps	9	6mm Lock Washers
4	20mm x 10mm Foam Sensor Spacers	9	6mm Hex Nuts
4	15.5mm x 25mm OD x 2mm Foam Sensor Seals	8	4mm x 20mm Button Head Bolts
1	4mm Allen Wrench	8	4mm Hex Nuts
1	2.5mm Allen Wrench	16	4mm x 8.65mm x 0.8mm Flat Washers
8	4mm Self Tapping Screws	8	4mm Lock Washers
8	12mm x 50mm Bolt Plates	6	Plastic Retainers

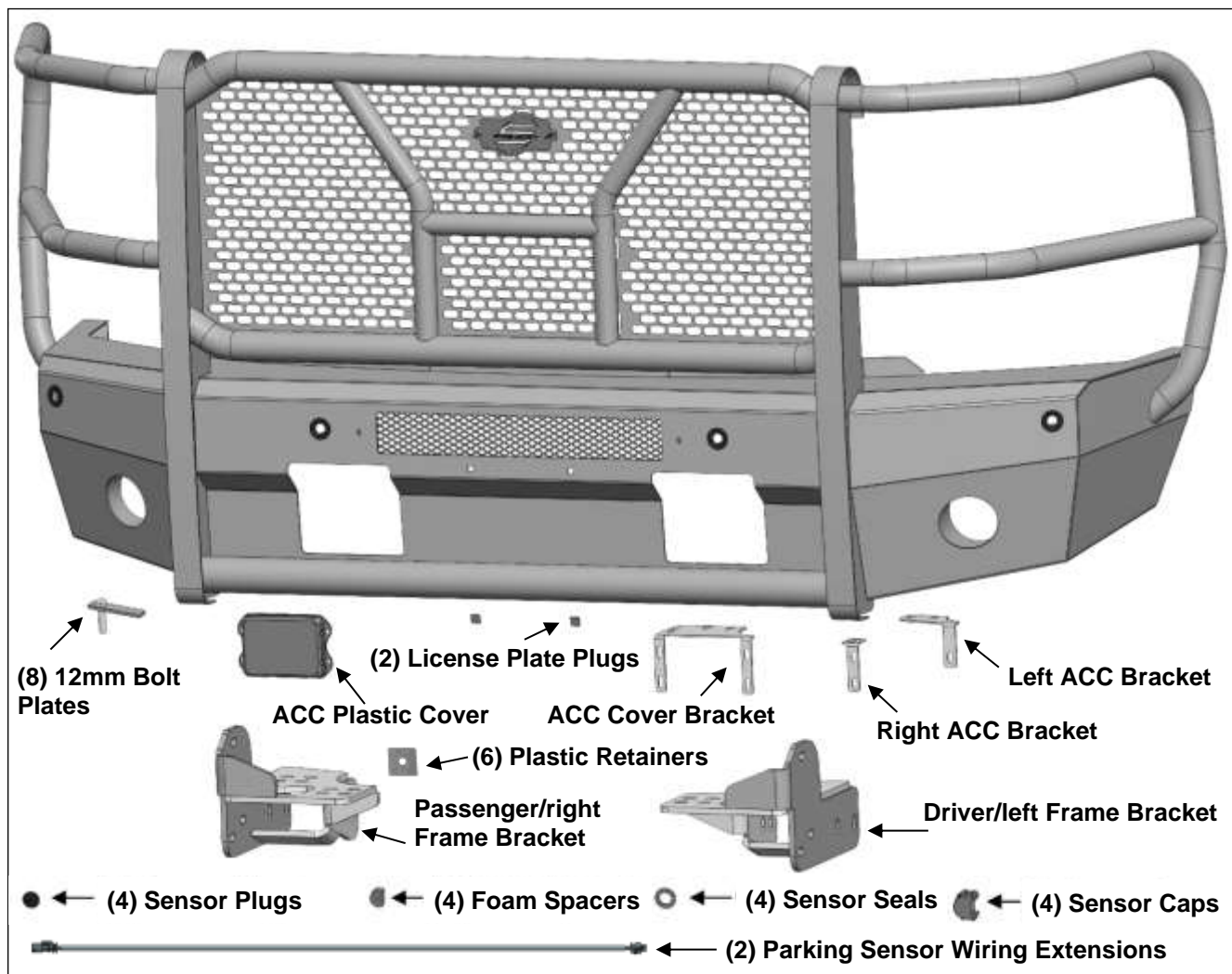

**ALUMINUM ELEVATION FRONT BUMPER
2023-25 FORD SUPER DUTY**

PROCEDURE:

REMOVE CONTENTS FROM BOX. VERIFY ALL PARTS ARE PRESENT. READ INSTRUCTIONS CAREFULLY BEFORE STARTING INSTALLATION. BUMPER IS HEAVY, ASSISTANCE IS HIGHLY RECOMMENDED TO AVOID POSSIBLE INJURY OR DAMAGE TO THE VEHICLE.

1. Remove the license plate. Unplug all wiring harnesses connecting bumper to vehicle **(Figure 1)**.
2. Remove the outer bumper support hardware attaching the outer ends of the bumper to the side of the frame, **(Figure 2)**. Remove the plastic covers from the tow hooks to uncover the bumper bolts, **(Figures 3 & 4)**.
3. Place blocks or jack stands under the front bumper to support it during mounting bolt removal. Once the bumper has been safely supported, remove the (8) factory bumper bolts beside the hooks, **(Figure 4)**. **WARNING!** Assistance is required to hold the bumper in place during bolt removal to prevent the bumper from falling. Carefully slide the bumper off, over the tow hooks. There will be 2 plastic pins that attach the bumper to the grille that need to be pried off **(Figure 5)**.
4. Remove the driver/left side tow hook by loosening the (4) factory hex bolts attaching the hook to the end of the frame, **(Figure 6)**. Next, remove the (4) factory hex nuts, lower frame extension and double bolt plates from the end of the frame, **(Figure 6)**. Repeat this Step to remove the passenger/right side tow hook and lower frame extension.
5. Next, select the driver/left Frame Bracket. Slide the Bracket over the end of the driverside frame rail. Line up the slots in the side of the Bracket with the holes in the outside of the frame. Select (4) 12mm Bolt Plates. Insert the Bolt Plates into the open end of the frame and out through the Bracket. Attach the Bracket to the Bolt Plates with (4) 12mm Flat Washers, (4) 12mm Lock Washers and (4) 12mm Hex Nuts, **(Figure 7 & 8)**. Leave loose at this time.
6. Attach the top of the Bracket to the top of the frame with the included (4) 12mm x 50mm Hex Bolts, (8) 12mm Flat Washers, (4) 12mm Lock Washers and (4) 12mm Hex Nuts, **(Figures 9 & 10)**. Do not fully tighten hardware at this time.
7. Reuse the factory hardware to attach the driver/left tow hook to the bottom of the Frame Bracket, **(Figure 10)**. **NOTE:** On models with **ACC sensor, driver/left side tow hook will not be reinstalled. See step 14.**
8. Repeat **Steps 5—7** to install the passenger/right Frame Bracket and tow hook.
9. Determine if truck is equipped with fog lights, otherwise skip to **step 10**.

Models with factory fog lights:

- a. Remove fog lights from the back of the OE bumper. Brackets may need to be removed to gain proper access **(Figure 11)**.
 - b. Move to the driver/left fog light opening. Place fog light into the fog light bracket on the new HD bumper. **(Figure 12)**. Attach fog light to the Bracket with the included (4) 4mm x 20mm socket head screws, (8) 4mm x 9mm STD Flat Washers, (4) 4mm lock washers and (4) 4mm hex nuts.
 - c. Repeat to install the passenger/right fog light.
10. Determine if truck is equipped with front parking sensors.

For vehicles not equipped with front parking sensors.

- a. Select the included (4) Plastic Parking Sensor Plugs. From the front of the bumper, push plugs into sensor holes until they snap into place, **(Figure 13)**.

For vehicles equipped with front parking sensors.

- a. Unplug and remove sensors from the OE bumper by spreading the plastic tabs apart on the sensor sleeve. Once free, remove the silicone seal from the end of the sensor. Remove the adhesive backing from the supplied 15.5mm x 25mm x 2mm Foam Washer Seal. Slide the Foam Seal over the front of the sensor **(Figure 14)**.
 - b. Insert sensor with Foam Seal into sensor sleeve, **(Figure 15)**.
 - c. Place (1) Foam Spacer on back of sensor. Push Sensor Retaining Cap onto sensor mount and lock into mounting holes, **(Figure 15)**.
 - d. Repeat previous Steps to install remaining sensors.
11. With assistance, carefully position the Bumper Assembly up to the outside of the Brackets. Temporarily support the weight of the Bumper. **WARNING:** To avoid possible injury or damage to the vehicle, do not proceed until the bumper is fully and safely supported.

ALUMINUM ELEVATION FRONT BUMPER 2023-25 FORD SUPER DUTY

12. Line up the (3) holes in the driver/left side of the Bumper with the (3) holes in the Frame Bracket. Attach the Bumper to the Bracket with the included (3) 12mm x 50mm Hex Bolts, (6) 12mm Flat Washers, (3) Plastic Retainers, (3) 12mm Lock Washers and (3) 12mm Hex Nuts, **(Figure 16)**. **NOTE:** Insert the Plastic Washers between the outer 12mm Flat Washers and the mounting plate on the back of the Bumper to minimize corrosion. Do not fully tighten hardware at this time. Repeat to attach the passenger/right side of the Bumper to the Bracket.
13. Level and adjust the bumper and fully tighten all 12mm hardware to 65-70ft-lbs.
14. Determine if truck is equipped with adaptive cruise control, (ACC).
 - Vehicles without Adaptive Cruise Control, skip to Step 15.**
 - a. Remove the 3 nuts securing the ACC sensor to the front of the OE bumper. **(Figure 17)**. Unplug the wiring harness and remove the sensor from the bumper.
 - b. Select the plastic ACC cover and ACC cover bracket. Insert (4) 6mm x 25mm Button Head Bolts through the (4) holes on the ACC Plastic Cover to each side of the ACC cover bracket. Secure with (4) 6mm x 18mm Flat Washers, (4) 6mm Lock Washers and (4) 6mm Hex Nuts, **(Figure 18)**.
 - c. Select the ACC sensor, Left ACC Bracket and Right ACC Bracket. Position the sensor between the Left and Right brackets **(Figure 19)**. Attach the sensor to the brackets with (3) 6mm x 30mm Hex Bolts, (6) 6mm x 18mm Flat Washers, (3) 6mm Lock Washers and (3) 6mm Hex Nuts. Do not tighten hardware.
 - d. Slide the ACC cover assembly into the driver side tow hook opening on the front of the bumper and place the ACC cover bracket on top of the tow hook mount on the driver side frame bracket. Then, position the ACC sensor assembly underneath the tow hook mount and attach the two assemblies together with the included (2) 8mm x 35mm Hex Bolts, (4) 8mm Flat Washers and (2) 8mm Nylon Lock Nuts, **(Figure 20)**. Then attach the top of the Right ACC bracket to the ACC cover bracket with (2) 6mm x 20mm Hex Bolts, (4) 6mm Flat Washers, (2) 6mm Lock Washers and (2) 6mm Hex Nuts.
 - e. Level and adjust the ACC sensor. Position plastic ACC cover so the sensor is centered behind it. Tighten all hardware.
15. Insert (2) Plastic License Plate Plugs into the Bumper. Reuse factory hardware to attach license plate to Plugs. On models with grille mounted factory camera, remove the center screen, **(Figure 21)**.
16. Re-attach the factory wiring harness to the sensors, fog lights and vehicle, (if equipped).
17. Do periodic inspections to the installation to make sure that all hardware is secure and tight.

To protect your investment, Do not use any type of polish or wax that may contain abrasives that could damage the finish. Mild soap may be used to clean the Elevation Front Bumper assembly.

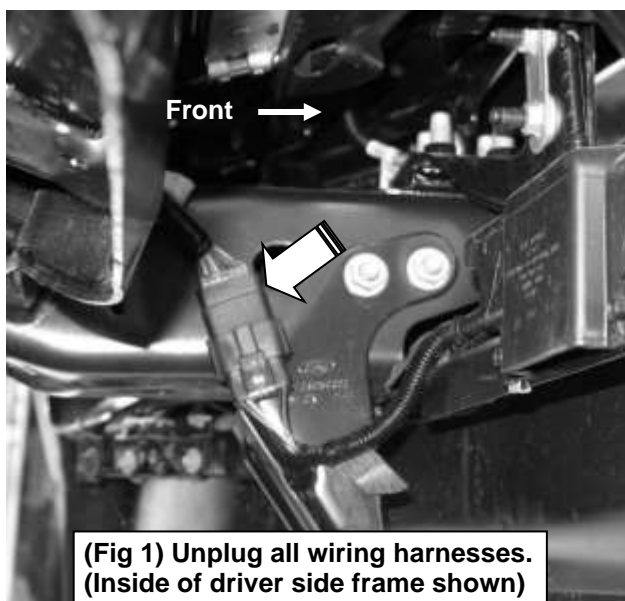

**(Fig 1) Unplug all wiring harnesses.
(Inside of driver side frame shown)**

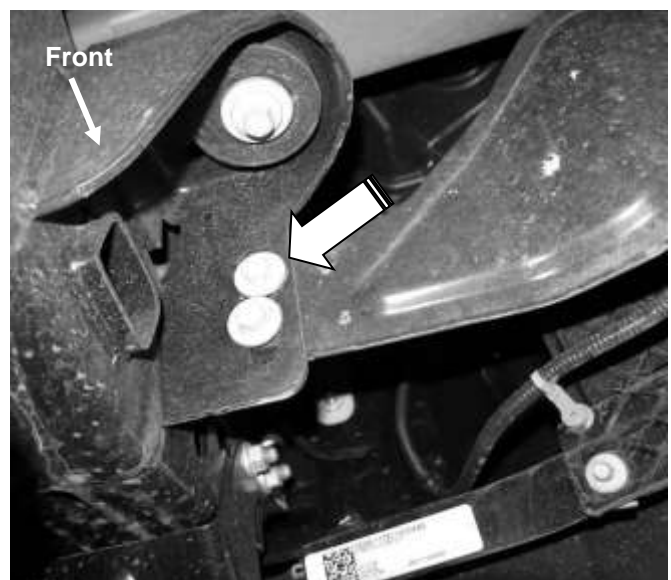

**(Fig 2) Remove outer bumper support
brackets between frame and bumper (arrow)
[Passenger side shown]**

**ALUMINUM ELEVATION FRONT BUMPER
2023-25 FORD SUPER DUTY**



(Fig 3) Remove plastic cover around tow hook

WARNING! Do not remove bumper bolts unless the bumper is properly supported on blocks or stands or it may fall.

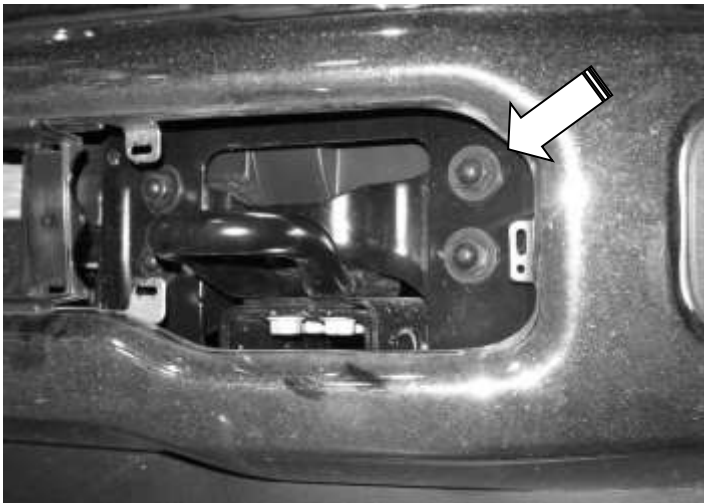

(Fig 4) Remove bumper bolts (driver side pictured)



(Fig 5) Remove the clips attaching rubber bumper trim to grille.

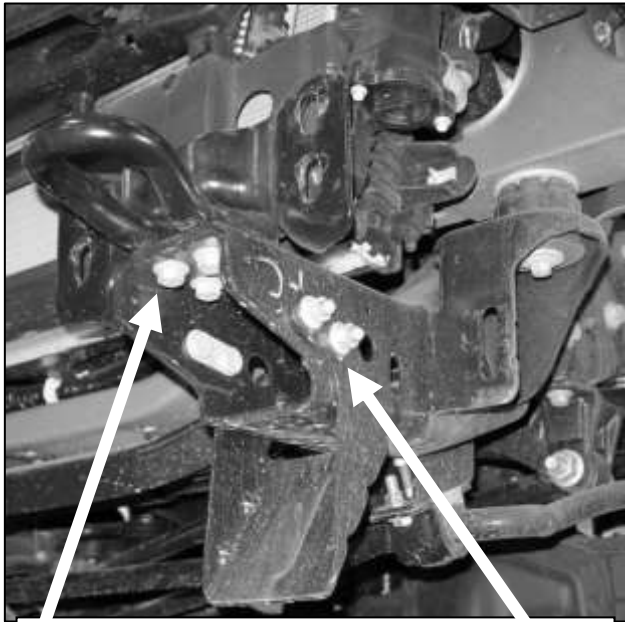

(Fig 6) Remove tow hook assembly and lower frame extension

Driver/left Side Installation Pictured

WARNING! Do not remove bumper bolts unless the bumper is properly supported on blocks or stands or it may fall.

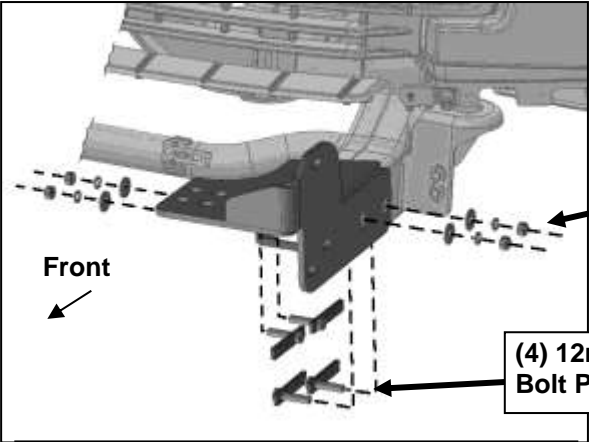

- (4) 12mm Flat Washers
- (4) 12mm Lock Washers
- (4) 12mm Hex Nuts

- (4) 12mm Bolt Plates

(Fig 7) Insert Bolt Plates into open end of frame. Attach Bracket to sides of frame

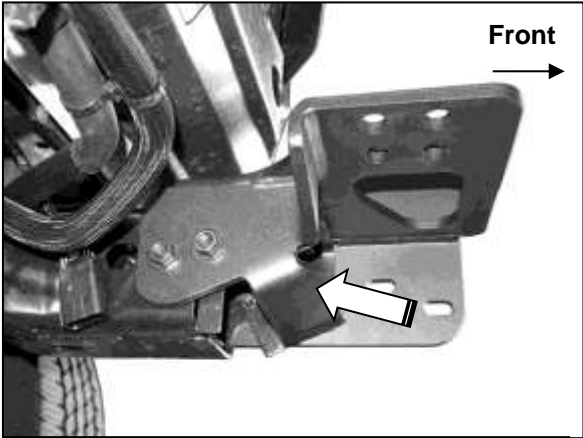

(Fig 8) Insert Bolt Plates into open end of frame (driver/left frame Bracket pictured)

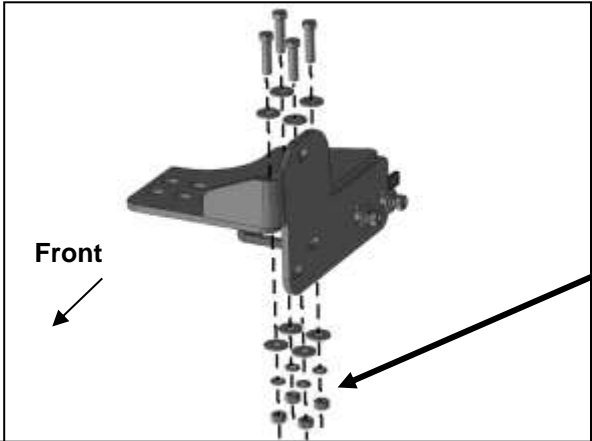

- (4) 12mm x 50mm Hex Bolts
- (8) 12mm Flat Washers
- (4) 12mm Lock Washers
- (4) 12mm Hex Nuts

(Fig 9) Attach top of Bracket to top of frame

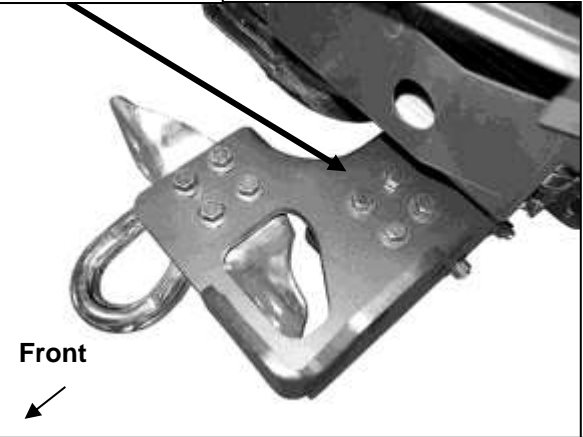

(Fig 10) Attach top of Bracket to top of frame. Reuse factory hardware to attach tow hook to Bracket (do not reinstall tow hook on driver/left side on models with ACC sensor)

**ALUMINUM ELEVATION FRONT BUMPER
2023-25 FORD SUPER DUTY**



(Fig 11) Unplug and remove fog lights from OE bumper (if equipped)

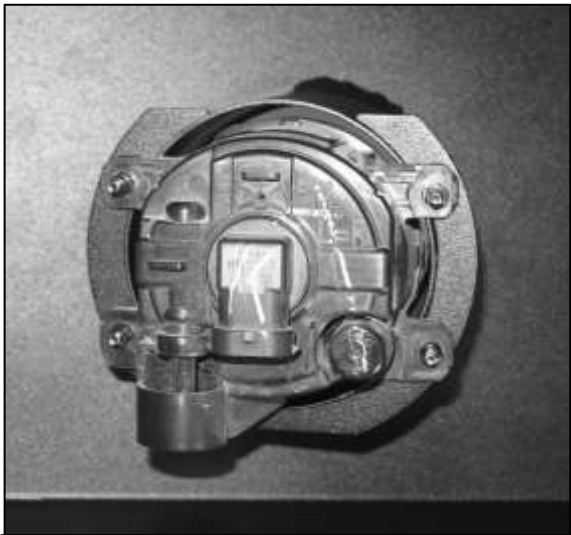

(Fig 12) Attach fog lights to bumper using 4mm hardware

Sensor Plug

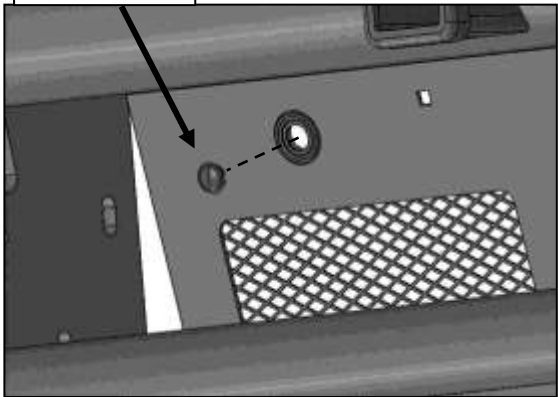

(Fig 13) Models without sensors: insert sensor plugs into the sensor hole

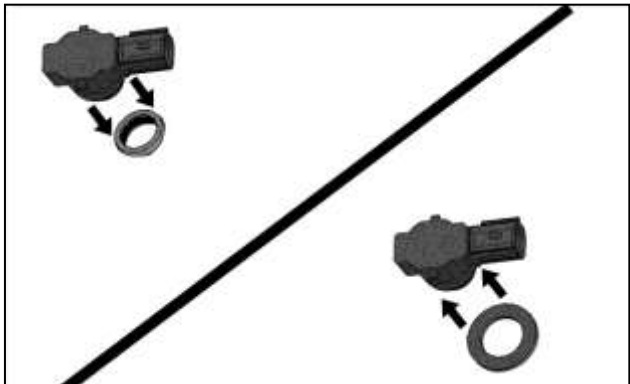

(Fig 14) Remove OE silicone seal from sensor. Slide large foam Seal over end of sensor (arrow)

**ALUMINUM ELEVATION FRONT BUMPER
2023-25 FORD SUPER DUTY**

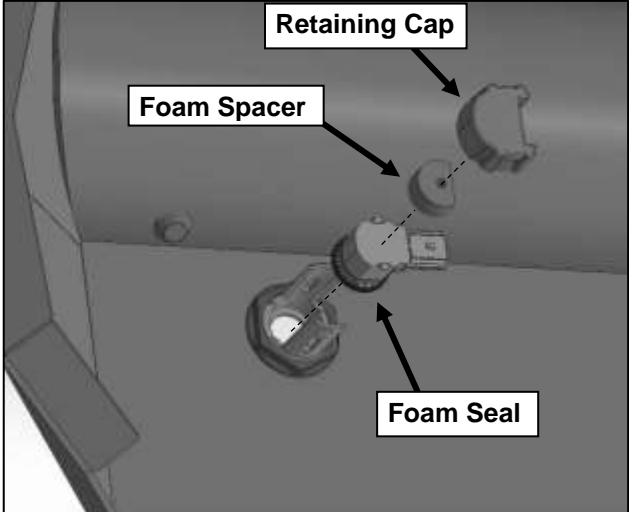

(Fig 15) Insert the sensor with seal into the sensor sleeve, followed by the foam spacer and retaining cap

WARNING! Do not crawl under bumper unless it is properly supported on blocks or stands or the bumper may fall.

- (3) 12mm x 50mm Hex Bolts
- (6) 12mm Flat Washers
- (3) 12mm Lock Washers
- (3) 12mm Hex Nuts

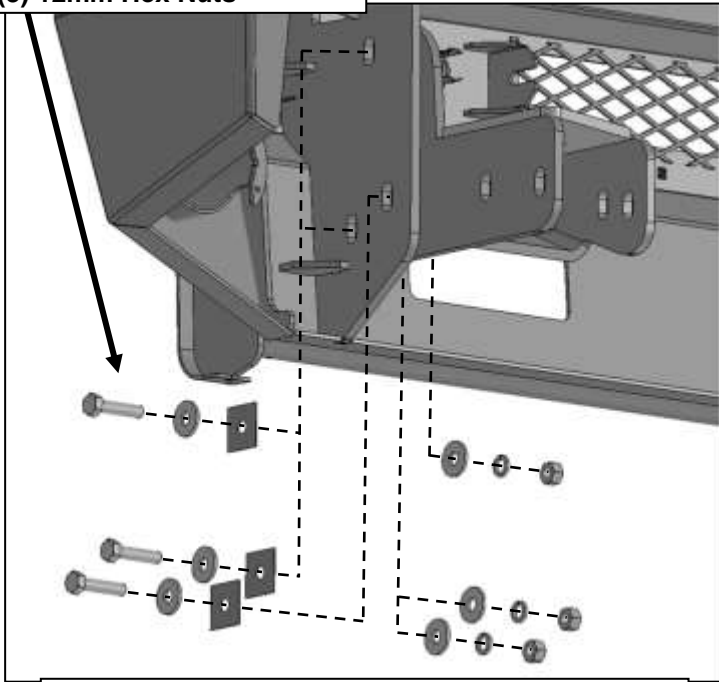

(Fig 16) Attach Bumper to side of Bracket. NOTE: Insert Plastic Washers between Flat Washer and mounting plate on Bumper to minimize corrosion



(Fig 17) Remove adaptive cruise control ACC” and parking sensors (if equipped)

- (4) 6mm Button Head Bolts
- (4) 6mm Flat Washers
- (4) 6mm Lock Washers
- (4) 6mm Hex Nuts

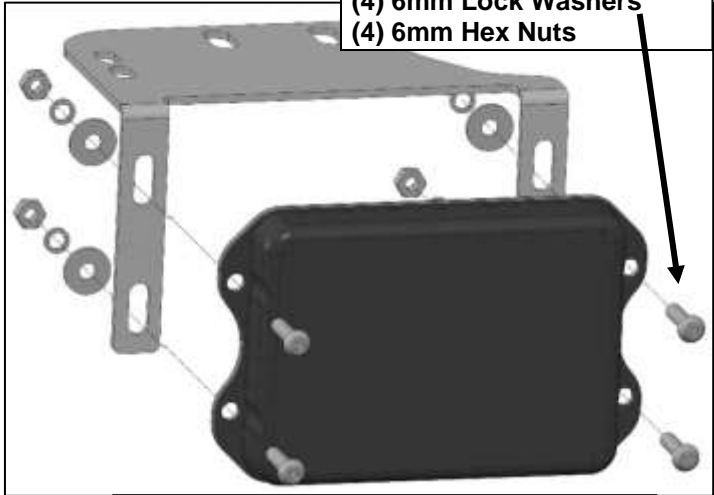

(Fig 18) Assemble ACC cover to the ACC cover bracket

**ALUMINUM ELEVATION FRONT BUMPER
2023-25 FORD SUPER DUTY**

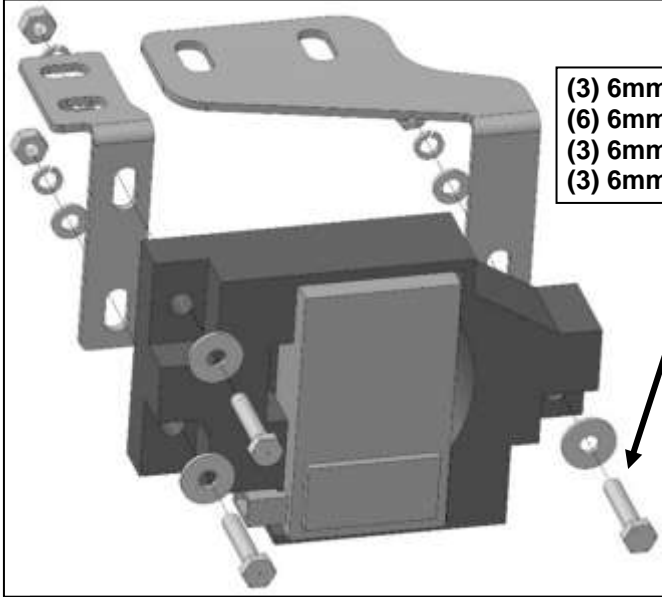

- (3) 6mm x 30mm Hex Bolts
- (6) 6mm Flat Washers
- (3) 6mm Lock Washers
- (3) 6mm Hex Nuts

- (2) 6mm x 20mm Hex Bolts
- (4) 6mm Flat Washers
- (2) 6mm Lock Washers
- (2) 6mm Hex Nuts

(Fig 19) Attach ACC sensor to ACC brackets

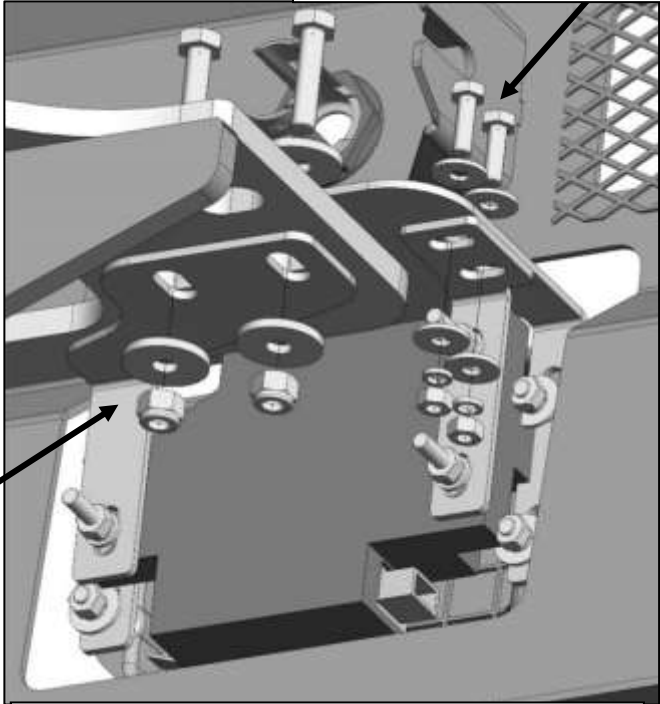

- (2) 8mm x 35mm Hex Bolts
- (4) 8mm x 28mm Flat Washers
- (2) 8mm Nylon Lock Nuts

(Fig 20) Attach ACC sensor assembly to driver side tow hook mount.

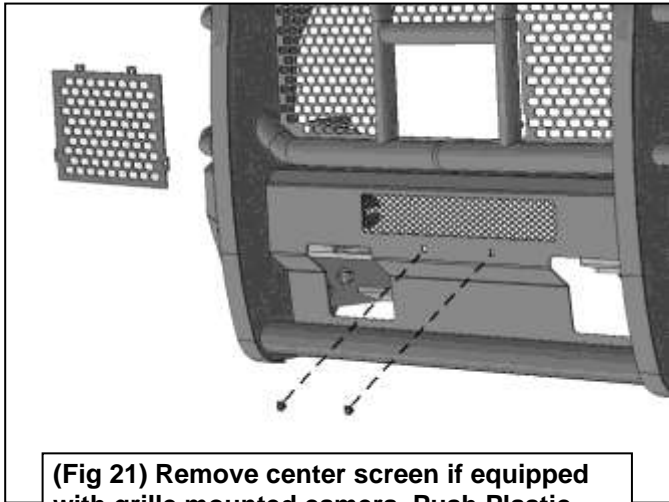

(Fig 21) Remove center screen if equipped with grille mounted camera. Push Plastic Plugs into holes in Bumper for license plate



Complete Installation