

**FORTIS FRONT BUMPER
2024-2025 GMC SIERRA 25-3500**

PARTS LIST:

1	Fortis Front Bumper Assembly	36	12mm x 32mm x 3mm Flat Washers
2	Driver/left Facing Support Bracket	18	12mm Nylon Lock Nuts
2	Passenger/right Facing Support Bracket	18	12mm x 50mm Hex Bolts
1	Driver/left Mounting Bracket	9	10mm x 40mm Hex Bolts
2	Passenger/right Mounting Bracket	10	10mm x 34mm x 3mm Flat Washers
2	Shutter Relocation Bracket	8	10mm Lock Washers
1	Block Heater Relocation Bracket	1	10mm Nylon Lock Nuts
1	Passenger/right LED Light Bar Bracket	4	8mm x 30mm Hex Bolts
1	Driver/left LED Light Bar Bracket	2	8mm x 16mm Hex Bolts
1	Sensor Cover Kit	10	8mm x 24mm x 2mm Flat Washers
4	Sensor Retaining Caps	6	8mm Lock Washers
4	Foam Sensor Sealing Washers	4	8mm Hex Nuts
4	Plastic Sensor Hole Plugs	4	6mm x 20mm Hex Bolts
4	20mm x 10mm Foam Sensor Spacers	8	6mm x 18mm x 1.6mm Flat Washer
2	Sensor Wiring Harness Extensions	4	6mm Nylon Lock Nuts
2	Plastic plugs for license plate	8	4mm Self-Tapping Plastic Screws
2	Rubber Edge Trim		

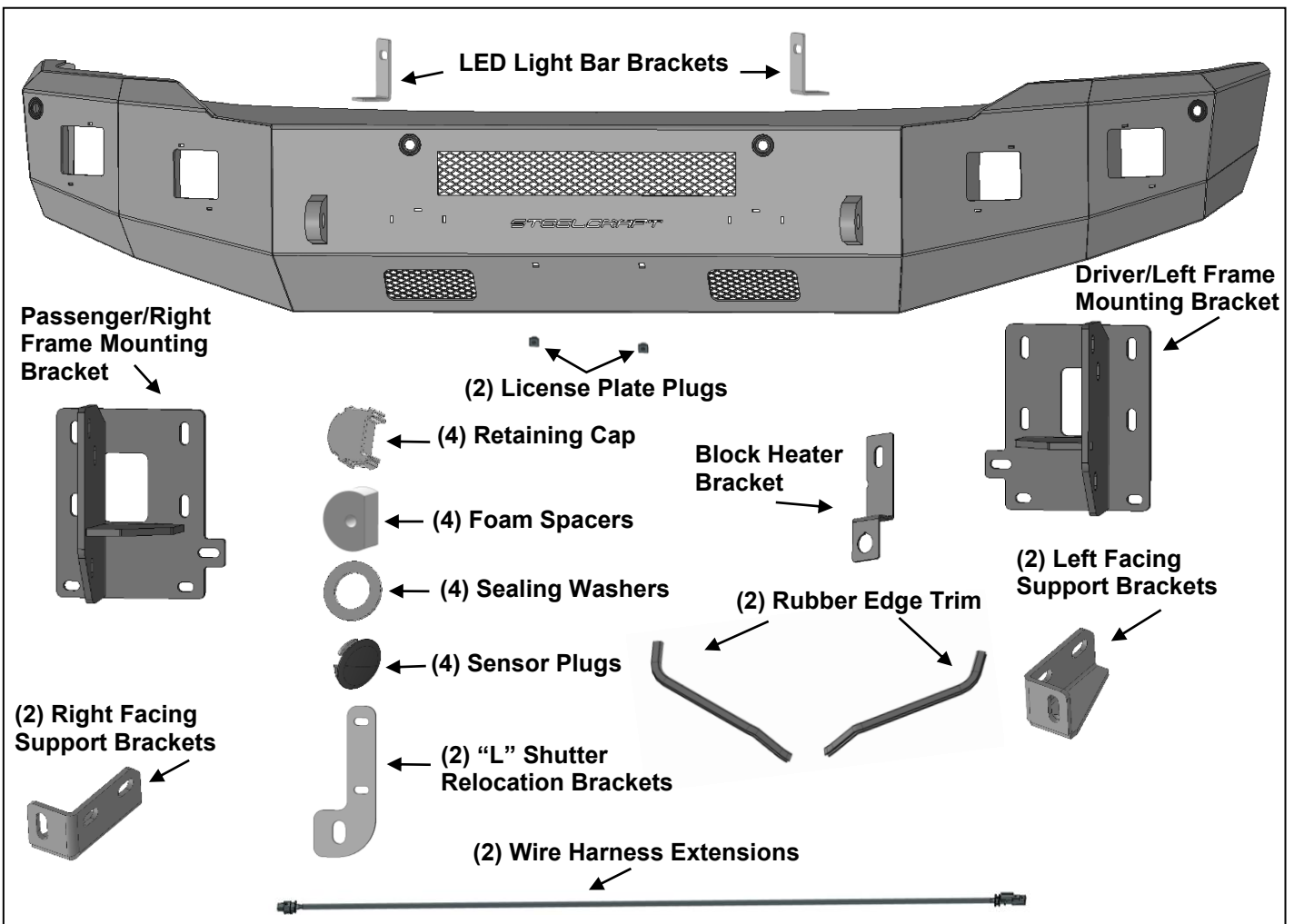

PROCEDURE:

REMOVE CONTENTS FROM PACKAGE AND VERIFY ALL PARTS ARE PRESENT. SOME PARTS ARE SMALL AND WILL BE HIDDEN IN WRAPPINGS. READ INSTRUCTIONS CAREFULLY BEFORE STARTING INSTALLATION. BUMPER IS HEAVY, ASSISTANCE IS HIGHLY RECOMMENDED TO AVOID POSSIBLE INJURY OR DAMAGE TO THE VEHICLE.

1. Open the hood and remove the hood release lever, **(Figure 1)**. Remove the plastic pins and cover from the top of the grille and radiator **(Figure 2)**. Temporarily reattach the release lever.
2. Remove the now exposed hardware attaching the top of the grille to the body.
3. Move to the wheel well, remove the 2 screws attaching the fender liner to the fascia panels **(Figure 3)**. Grab plastic fender flare and pull to release plastic pins securing the plastic fender flare to body, **NOTE:** flare does not need to be fully removed, only the first few pins. Remove the now exposed small hex bolt attaching fascia to body **(Figure 4)**.
4. On models with grille mounted camera, unplug all harnesses and hoses leading to the camera.
5. Once all attaching screws and clips have been removed, pull grille straight out to release from clips, **(Figure 5)**.
6. From under the vehicle, remove the hardware at each end of the bumper attaching the bumper supports to each side of the frame, **(Figure 6)**.
7. Place blocks or jack stands under the front bumper to support it during mounting bolt removal. Once the bumper has been safely supported, from above the bumper, remove the (2) factory upper and lower bumper bolts from each side, **(Figure 7)**. **WARNING!** Assistance is required to hold the bumper in place during bolt removal to prevent the bumper from falling. Remove the bumper assembly. Move the bumper to a clean surface.
8. Remove the factory bumper brackets and tow hooks, (if equipped), from the end of frame, **(Figure 8 & 9)**. On models with lower radiator shutter assembly, unplug and remove the assembly. **NOTE:** Tow hooks cannot be reinstalled.
9. Select (1) Left Facing Lower Support Bracket, **(Figure 10)**. Attach the Left Facing Support Bracket to the outermost side of the driver side frame with the included (2) 12mm x 50mm Hex Bolts, (4) 12mm Flat Washers, (2) 12mm Lock Washers and (2) 12mm Hex Nuts. Do not fully tighten hardware at this time. Repeat this **Step** to attach (1) Right Facing Support Bracket to the inner side of the driver side frame.
10. Select the Driver/left Frame Mounting Bracket, **(Figure 11)**. Attach the Bracket to the mounting plate on the end of the frame with the included (4) 10mm x 40mm Hex Bolts, (4) 10mm Lock Washers and (4) 10mm x 34mm large Flat Washers. Do not fully tighten at this time.
11. Attach the bottom of the Frame Bracket to the front of the Support Brackets with (2) 12mm x 50mm Hex Bolt, (4) 12mm Flat Washers, (2) 12mm Lock Washers and (2) 12mm Hex Nuts, **(Figures 12 & 13)**. Do not fully tighten at this time.
12. Repeat **Steps 9—11** to install the passenger/right Frame Bracket and Support Brackets.
13. Only on models equipped with lower radiator shutter system, remove shutter assembly from outer plastic housing, **(Figure 14)**. Select (1) "L" Relocation Bracket. Attach the "L" Bracket to the front of the Frame Mounting Bracket with the included (1) 8mm x 30mm Hex Bolt, (2) 8mm Flat Washers and (1) 8mm Nylon Lock Nut. Repeat this Step to attach the remaining "L" Bracket, **(Figure 15)**.
14. If equipped, attach the shutter assembly to the front of the "L" Brackets with the included (4) 6mm x 20mm Hex Bolts, (8) 6mm Flat Washers and (4) 6mm Nylon Lock Nuts, **(Figures 15 & 16)**. Do not overtighten the 6mm hardware or damage to the shutter assembly may result. **NOTE:** Shutter assembly may be installed upside-down. Plug wiring harness into shutter assembly
15. Reattach grille, camera, and hoses that were removed in **Step 4**.
16. **Optional Center LED light installation**, (sold separately). **NOTE:** Light may be easier to install in Bumper before Bumper Assembly is attached to Brackets
 - a. Select the Driver side "L" Bracket, **(Figure 17)**. **NOTE:** "L" Brackets are offset for universal fitment for most LED bar style lights. Attach the Bracket to the top of the mounting tab on the back of the Bumper with the included (1) 8mm x 30mm Hex Bolt, (2) 8mm Flat Washers, (1) 8mm Lock Washer and (1) 8mm Hex Nut, **(Figure 17)**. Do not tighten hardware at this time.
 - b. Repeat Previous Step for Passenger side "L" LED Light Bar Bracket installation.

**FORTIS FRONT BUMPER
2024-2025 GMC SIERRA 25-3500**

- c. Attach the LED Light Bar to the Brackets with (2) 8mm x 16mm Hex Bolts, (2) 8mm Lock Washers and (2) 8mm Flat Washers, **(Figure 17)**. Do not fully tighten hardware at this time.
 - d. Center and adjust light position and tighten hardware.
 - e. Follow light manufacturer's instructions to wire the light to the vehicle's electrical system once Bumper has been fully installed.
17. Disassemble the front bumper to access and remove the sensors and wiring harness as equipped, **(Figure 18)**. Sensors, (if equipped), must be installed in Bumper before installing Bumper Assembly.
- Models without bumper sensors:**
- a. From the front of the Bumper, push the included Plastic Plugs into the sensor mounting holes, **(Figure 19)**.
- Models with bumper mounted sensors:**
- a. Select the driver/left outer sensor.
 - b. Remove the silicone seal from the end of the sensor. Slide the included larger Sensor Seal over front of sensor, **(Figure 20)**.
 - c. Insert sensor with Seal into sensor mount, **(Figure 21)**.
 - d. Place Foam Spacer over the end of sensor. Push Sensor Retaining Cap onto sensor mount and lock into mounting holes, **(Figure 21)**.
 - e. Repeat previous Steps to install remaining sensors.
18. Install the factory bumper wiring harness for sensors as equipped. Run wiring harness through Brackets to reach sensors, **(Figure 22)**. **NOTE:** (2) Wire Harness Extensions have been included to extend the factory harness to reach the sensors as needed.
19. Push the (2) Rubber Edge Trim pieces onto the top edge of the Bumper to protect vehicle fascia during install, **(Figure 23)**. Repeat this Step to the other side.
20. With assistance, position the Bumper Assembly up to and over the Brackets. Temporarily support the weight of the Bumper. **WARNING:** To avoid possible injury or damage to the vehicle, do not proceed until the Bumper is fully and safely supported.
21. Line up the (3) holes in the driver/left side mounting plate on the inside of the Bumper with the (3) slots in the Frame Bracket. Attach the Bumper to the Bracket with the included (3) 12mm x 50mm Hex Bolts, (6) 12mm Flat Washers, (3) 12mm Lock washers and (3) 12mm Hex Nuts, **(Figures 24)**. Do not fully tighten hardware at this time. Repeat this Step to attach the passenger/right side of the Bumper.
22. Level and adjust the Bumper and fully tighten all 12mm hardware to 65-70ft-lbs. Plug in sensor wires to main vehicle harness.
23. **(Optional)** Attach engine Block Heater Bracket to the bumper bracket support, **(Figure 25 & 26)**.
24. Use the included (2) push-in Plastic Plugs to attach the front license plate, (if required), to the (2) holes in the front Bumper, **(Figure 27)**.
25. Do periodic inspections to the installation to make sure that all hardware is secure and tight.



(Fig 1) Remove hood release lever (arrow).



(Fig 2) Remove the plastic pins and cover from the top of the grille and radiator, then temporarily reinstall the hood release

Driver/left Side Installation Pictured

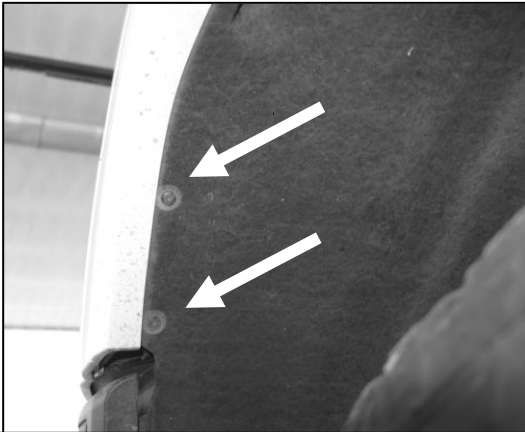

(Fig 3) Remove the 2 screws attaching the fender liner to the fascia panels



(Fig 4) Firmly pull flare to expose hex bolt.



(Fig 5) Once both fascia body panels (arrows) have been loosened, remove grille

WARNING! Do not crawl under bumper unless it is properly supported on blocks or stands or the bumper may fall.

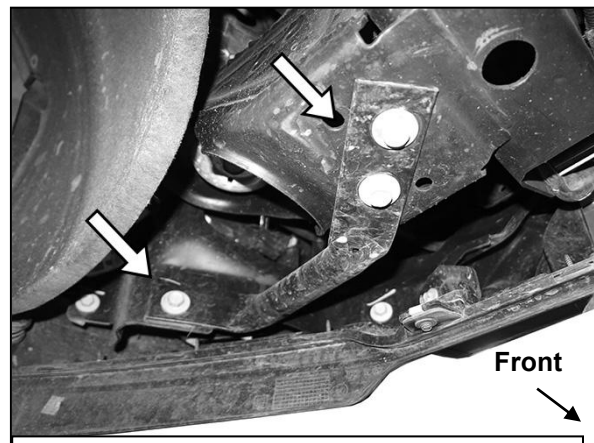

(Fig 6) Remove the outer bumper supports attached to the bottom of the frame

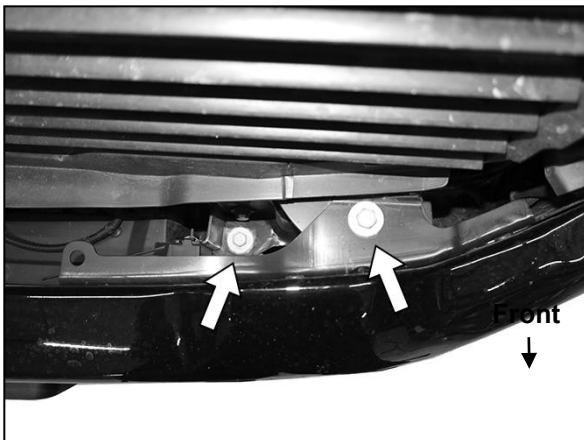

(Fig 7) From above, remove the hex bolts attaching the bumper assembly to the frame bumper brackets (top visible-arrow)

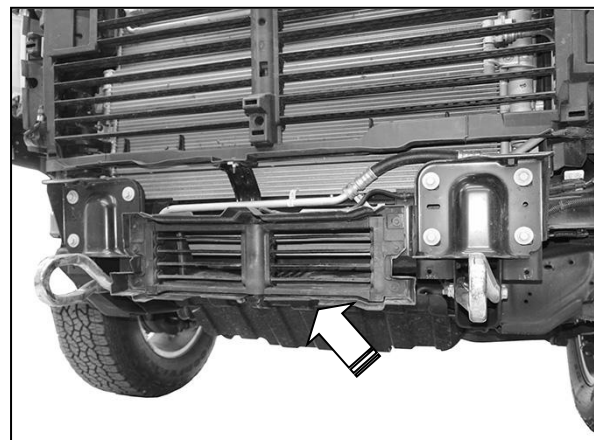

(Fig 8) Remove tow hooks and bumper brackets. Unplug and remove the shutter assembly (arrow) if equipped

Driver/left Side Installation Pictured



(Fig 9) Bumper removed

- (2) 12mm x 50mm Hex Bolts
- (8) 12mm Flat Washers
- (4) 12mm Nylon Lock Nuts

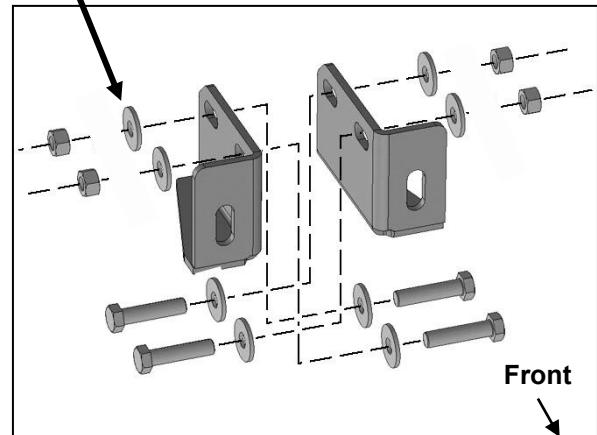

(Fig 10) Attach (1) Left Facing and (1) Right Facing Support Bracket to the sides of the frame

- (4) 10mm x 40mm Hex Bolts
- (4) 10mm Flat Washers
- (4) 10mm Lock Washers

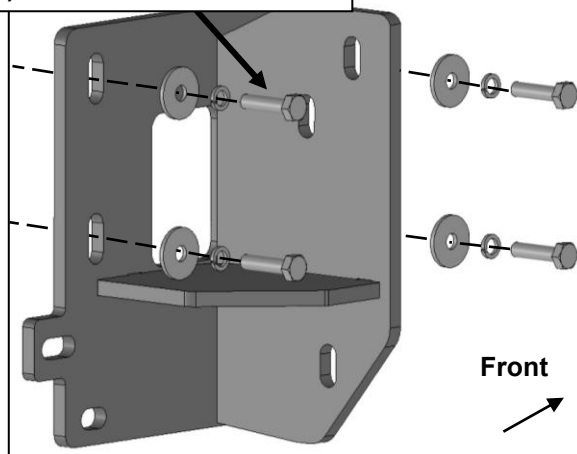

(Fig 11) Attach Driver/left Frame Bracket to end of frame

- (2) 12mm x 50mm Hex Bolts
- (4) 12mm Flat Washers
- (2) 12mm Nylon Lock Nuts

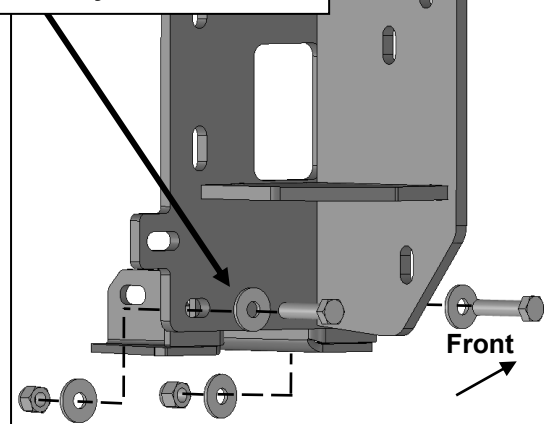

(Fig 12) Attach the Support Brackets to the bottom slots in the driver/left Frame Bracket

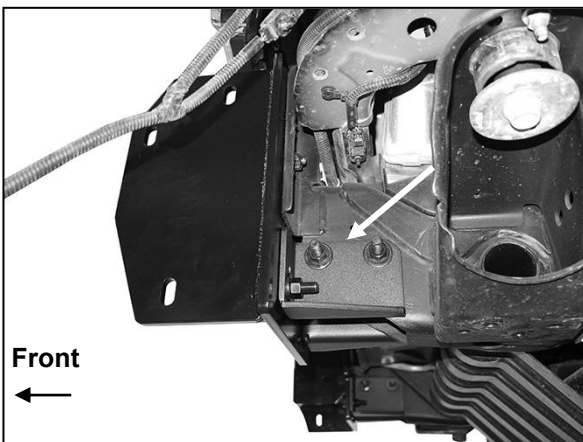

(Fig 13) Left facing Support Bracket installed

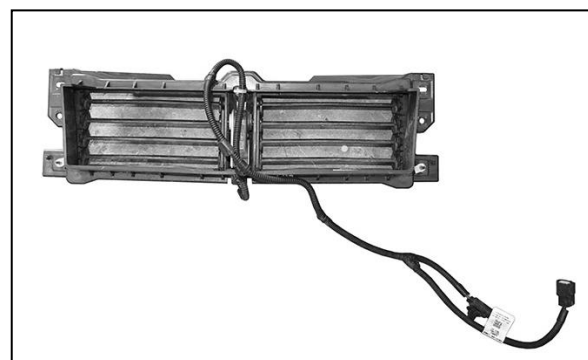

(Fig 14) Remove inner shutter assembly from plastic outer housing (if equipped)

Driver/left Side Installation Pictured

- (1) 8mm x 30mm Hex Bolt
- (2) 8mm Flat Washers
- (1) 8mm Lock Washer
- (1) 8mm Hex Nut

- (2) 6mm x 20mm Hex Bolts
- (4) 6mm Flat Washers
- (2) 6mm Nylon Lock Nuts

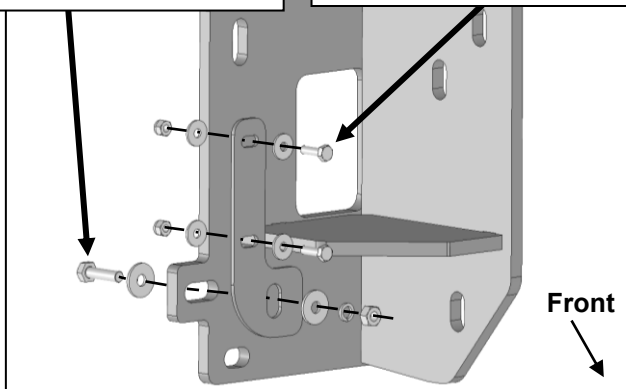

(Fig 15) Attach "L" Relocation Brackets to front of Frame Brackets. Attach shutter assembly to front of Relocation Brackets if equipped

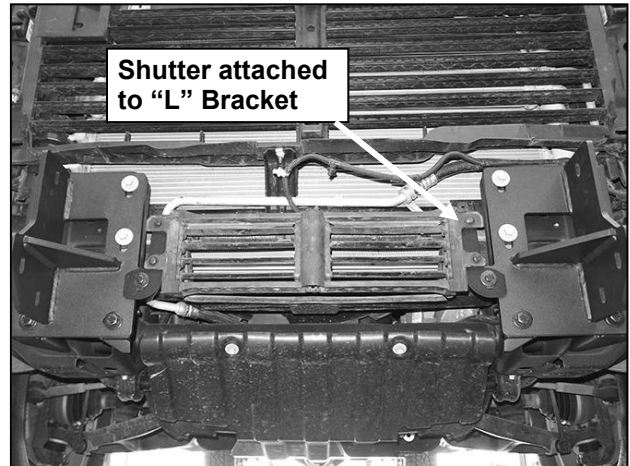

(Fig 16) Attach shutter assembly, (if equipped), to front of Relocation Brackets

- (1) 8mm x 16mm Hex Bolts
- (1) 8mm Flat Washers
- (1) 8mm Lock Washer

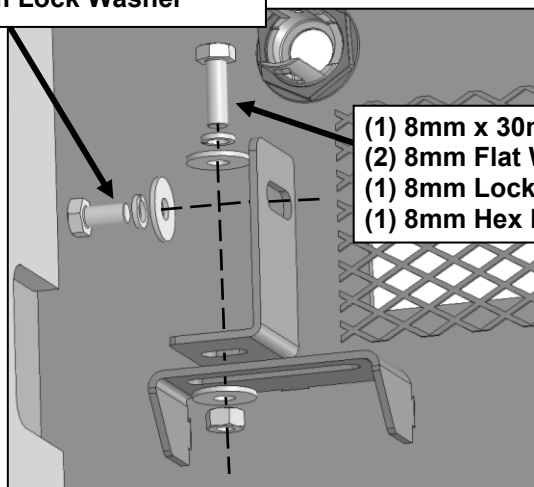

- (1) 8mm x 30mm Hex Bolt
- (2) 8mm Flat Washers
- (1) 8mm Lock Washer
- (1) 8mm Hex Nut

(Fig 17) Universal LED Light Bar Brackets (light not included)

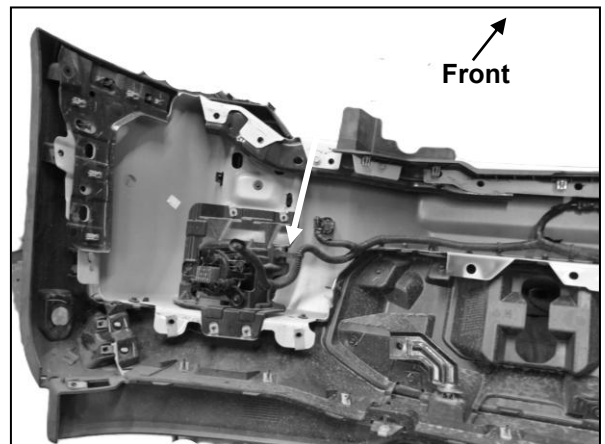

(Fig 18) Disassemble bumper and remove sensors and wiring harness as equipped

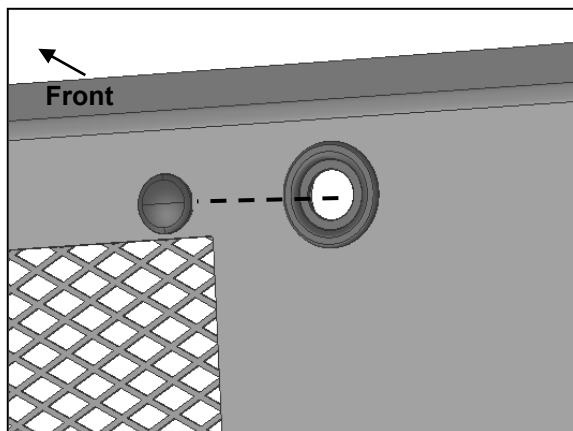

(Fig 19) Push Plug into sensor mount

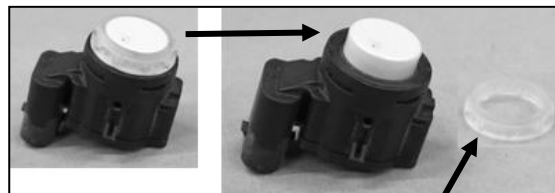

Remove silicone seal

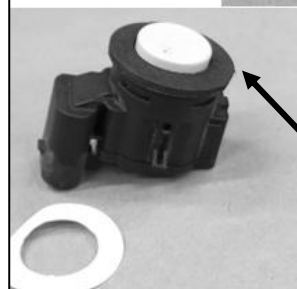

Slide Foam Seal over end of sensor

(Fig 20) Remove silicone seal from sensor. Slide large Seal over end of sensor

Driver/left Side Installation Pictured

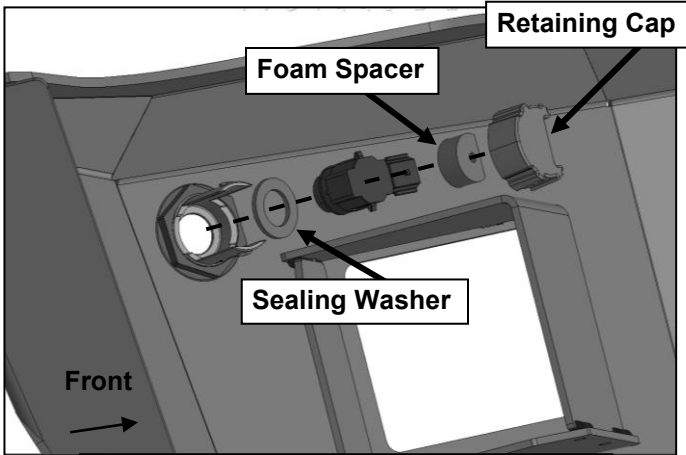

(Fig 21) Insert sensor assembly through the sensor sleeve behind the Bumper

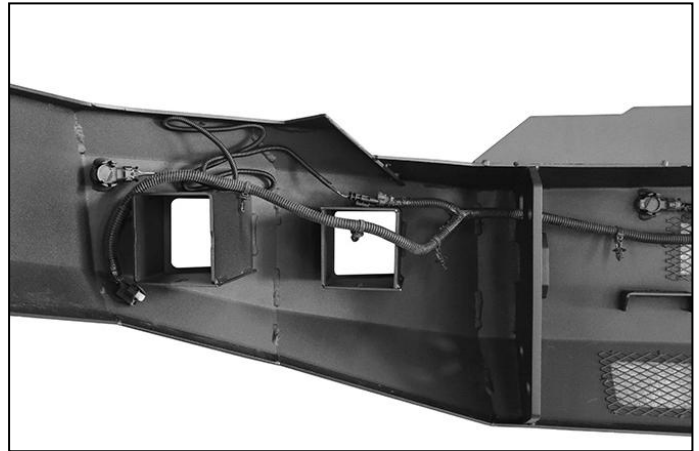

(Fig 22) Use the included (2) Wire Harness Extensions as necessary to reach the parking sensors

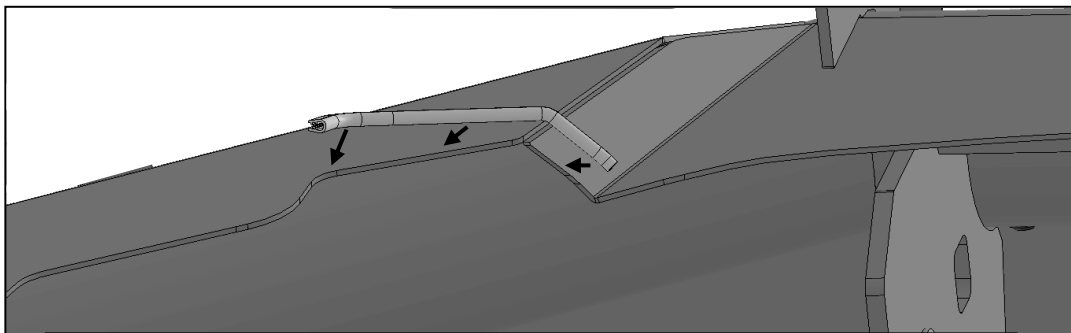

(Fig 23) Attach Rubber Edge Trim onto top of the bumper to protect fascia.

- (3) 12mm x 50mm Hex Bolts
- (6) 12mm Flat Washers
- (3) 12mm Lock Washers
- (3) 12mm Hex Nuts

WARNING! Do not crawl under bumper unless it is properly supported on blocks or stands or the bumper may fall.

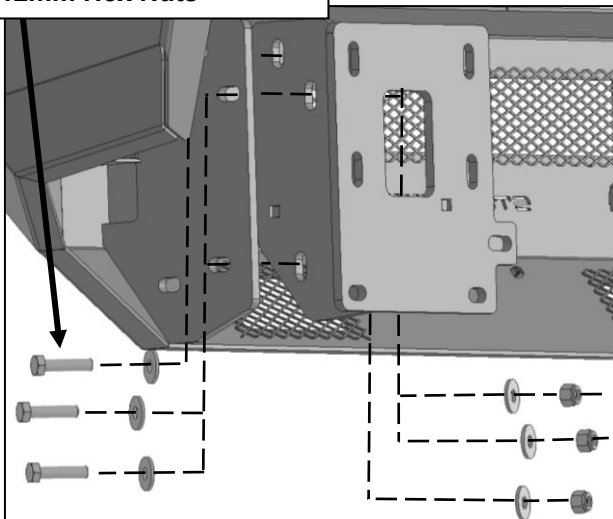

(Fig 24) Attach the Bumper to Frame Brackets

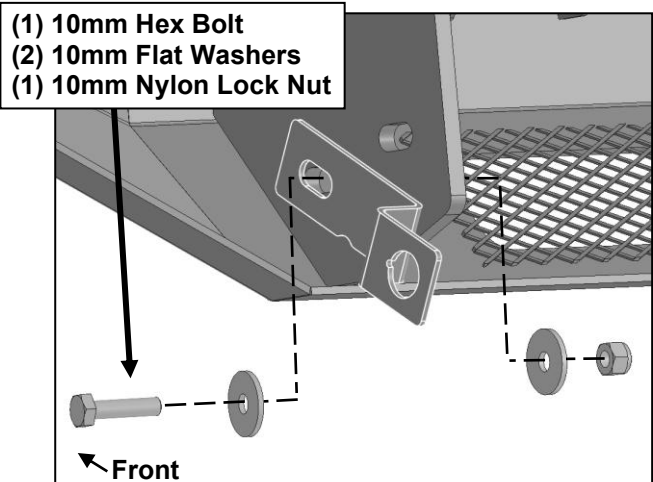

(Fig 25) Engine block heater relocation bracket example (Optional)

Driver/left Side Installation Pictured



(Fig 26) Driver/left side of Bumper installed
(Optional Block Heater installed)

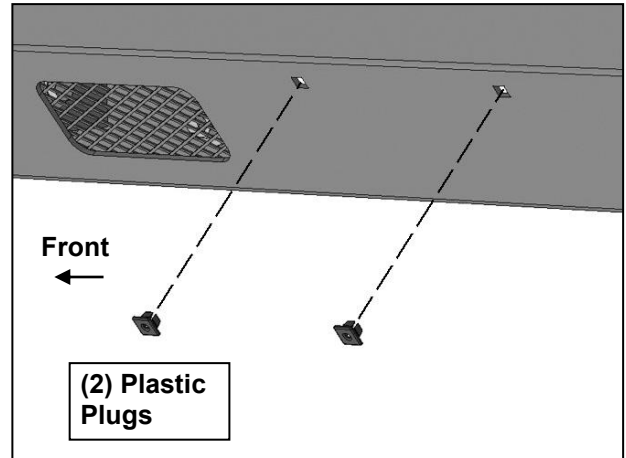

(Fig 27) Push Plastic Plugs into hole in
Bumper for License Plate



Complete Installation

To protect your investment, Do not use any type of polish or wax that may contain abrasives that could damage the finish. Mild soap may be used to clean the Front Bumper assembly.